

VSA Programming Commands
January 9, 2003 5:01 pm

E4406A VSA Series Transmitter Tester



Agilent Technologies

Manufacturing Part Number: E4406-90109

Printed in USA

January 9, 2003 5:01 pm

© Copyright 1999-2003 Agilent Technologies

The information contained in this document is subject to change without notice.

Agilent Technologies makes no warranty of any kind with regard to this material, including but not limited to, the implied warranties of merchantability and fitness for a particular purpose. Agilent Technologies shall not be liable for errors contained herein or for incidental or consequential damages in connection with the furnishing, performance, or use of this material.

Commands

*CAL? 67

*CLS 67

*ESE <number> 67

*ESE? 67

*ESR? 68

*IDN? 68

*LRN? 68

*OPC 69

*OPC? 69

*OPT? 70

*RCL <register> 70

*RST 70

*SAV <register> 71

*SRE <integer> 71

*SRE? 71

*STB? 71

*TRG 71

*TST? 72

*WAI 72

:ABORt 73

:CALCulate:<measurement>:MARKer:AOff 108

:CALCulate:<measurement>:MARKer[1] | 2 | 3 | 4:FUNction:RESult? 108

:CALCulate:<measurement>:MARKer[1] | 2 | 3 | 4:MAXimum 108

:CALCulate:<measurement>:MARKer[1] | 2 | 3 | 4:MINimum 109

:CALCulate:<measurement>:MARKer[1] | 2 | 3 | 4:MODE POSition | DELTa 109

:CALCulate:<measurement>:MARKer[1] | 2 | 3 | 4:MODE? 109

:CALCulate:<measurement>:MARKer[1] | 2 | 3 | 4:TRACe <trace_name> 110

:CALCulate:<measurement>:MARKer[1] | 2 | 3 | 4:TRACe? 110

:CALCulate:<measurement>:MARKer[1] | 2 | 3 | 4:X <param> 114

:CALCulate:<measurement>:MARKer[1] | 2 | 3 | 4:X:POSition <integer> 114

:CALCulate:<measurement>:MARKer[1] | 2 | 3 | 4:X:POSition? 114

Commands

:CALCulate:<measurement>:MARKer[1] | 2 | 3 | 4:X? 114
:CALCulate:<measurement>:MARKer[1] | 2 | 3 | 4:Y? 115
:CALCulate:<measurement>:MARKer[1] | 2 | 3 | 4[:STATe] OFF | ON | 0 | 1 109
:CALCulate:<measurement>:MARKer[1] | 2 | 3 | 4[:STATe]? 109
:CALCulate:ACP:LIMit:STATe OFF | ON | 0 | 1 75
:CALCulate:ACP:LIMit:STATe? 75
:CALCulate:ACP:LIMit[:TEST] OFF | ON | 0 | 1 75
:CALCulate:ACP:LIMit[:TEST]? 75
:CALCulate:BER:FRAMes <integer> 76
:CALCulate:BER:FRAMes? 76
:CALCulate:BER:LIMit:ERATe <percent> 76
:CALCulate:BER:LIMit:ERATe? 76
:CALCulate:BER:LIMit:STATe OFF | ON | 0 | 1 76
:CALCulate:BER:LIMit:STATe? 76
:CALCulate:CDPower:ASET:THReshold <numeric> 77
:CALCulate:CDPower:ASET:THReshold:AUTO OFF | ON | 0 | 1 77
:CALCulate:CDPower:ASET:THReshold:AUTO? 77
:CALCulate:CDPower:ASET:THReshold? 77
:CALCulate:CDPower:AXIS[:MS] IPH | QPH 77
:CALCulate:CDPower:AXIS[:MS]? 77
:CALCulate:CDPower:CHANnel:TYPE DATA | MAC | PILOt 78
:CALCulate:CDPower:CHANnel:TYPE? 78
:CALCulate:CDPower:DBITs:THReshold? 78
:CALCulate:CDPower:DBITs:TRIState:THReshold <float> 78
:CALCulate:CDPower:DBITs[:FORMat] BINary | TRIState 78
:CALCulate:CDPower:DBITs[:FORMat]? 78
:CALCulate:CDPower:IQ:COMBined[:STATe]? 78
:CALCulate:CDPower:IQ:COMBined[:STATe]OFF | ON | 0 | 1 78
:CALCulate:CDPower:PNOFfset <time> 79
:CALCulate:CDPower:PNOFfset? 79
:CALCulate:CDPower:SBOundary:COMPosite OFF | ON | 0 | 1 79

Commands

:CALCulate:CDPower:SBOundary:COMPOSITE? 79
:CALCulate:CDPower:SBOundary:SRATE <integer> 80
:CALCulate:CDPower:SBOundary:SRATE? 80
:CALCulate:CDPower:SBOundary:WCODE[:LENGTH] <integer> 80
:CALCulate:CDPower:SBOundary:WCODE[:LENGTH]? 80
:CALCulate:CDPower:SPRead <integer> 80
:CALCulate:CDPower:SPRead? 80
:CALCulate:CDPower:SRATE <integer> 81
:CALCulate:CDPower:SRATE? 81
:CALCulate:CDPower:SWEep:OFFSet <float> 81
:CALCulate:CDPower:SWEep:OFFSet <integer> 81
:CALCulate:CDPower:SWEep:OFFSet? 81
:CALCulate:CDPower:SWEep:TIME <float> 82
:CALCulate:CDPower:SWEep:TIME <integer> 82
:CALCulate:CDPower:SWEep:TIME? 82
:CALCulate:CDPower:TDPCh <integer> 83
:CALCulate:CDPower:TDPCh:AUTO OFF | ON | 0 | 1 83
:CALCulate:CDPower:TDPCh:AUTO? 83
:CALCulate:CDPower:TDPCh? 83
:CALCulate:CDPower:TYPE ABSolute | RELative 84
:CALCulate:CDPower:TYPE:DATA OPSK | QAM | QPSK 84
:CALCulate:CDPower:TYPE:DATA? 84
:CALCulate:CDPower:TYPE? 84
:CALCulate:CDPower:WCODE:BASE <integer> 84
:CALCulate:CDPower:WCODE:BASE? 84
:CALCulate:CDPower:WCODE:LENGTH <integer> 84
:CALCulate:CDPower:WCODE:LENGTH? 85
:CALCulate:CDPower:WCODE:ORDER BREVerse | 85
:CALCulate:CDPower:WCODE:ORDER? 85
:CALCulate:CDPower:WCODE[:NUMBER] <integer> 85
:CALCulate:CDPower:WCODE[:NUMBER]? 85

Commands

:CALCulate:CLIMits:FAIL? 89

:CALCulate:DATA<n>:COMPRESS? BLOCk | CFIT | MAXimum | MEAN | MINimum | RMS | SAM-
Ple | SDEVIation
[,<soffset>[,<length>[,<roffset>[,<rlimit>]]]] 89

:CALCulate:DATA<n>:PEAKs? <threshold>,<excursion>[,AMPLitude | FREQuency | TIME] 99

:CALCulate:DATA[n]? 89

:CALCulate:ETSPur:LIMit:TEST ABSolute | RELative 101

:CALCulate:ETSPur:LIMit:TEST? 101

:CALCulate:ETSPur:LIMit[:UPPer][:DATA] <power> 101

:CALCulate:ETSPur:LIMit[:UPPer][:DATA]? 101

:CALCulate:EVM:LIMit:F10 <percent> 102

:CALCulate:EVM:LIMit:F10? 102

:CALCulate:EVM:LIMit:IQOOffset <dB> 102

:CALCulate:EVM:LIMit:IQOOffset? 102

:CALCulate:EVM:LIMit:PEAK <percent> 102

:CALCulate:EVM:LIMit:PEAK? 102

:CALCulate:EVM:LIMit:RMS <percent> 103

:CALCulate:EVM:LIMit:RMS? 103

:CALCulate:EVM:LIMit[:TEST] OFF | ON | 0 | 1 103

:CALCulate:EVM:LIMit[:TEST]? 103

:CALCulate:EVM:TTSWord? 103

:CALCulate:EVMQpsk:IQOOffset:INCLude OFF | ON | 0 | 1 104

:CALCulate:EVMQpsk:IQOOffset:INCLude? 104

:CALCulate:EVMQpsk:LIMit:FERRor <float> 104

:CALCulate:EVMQpsk:LIMit:FERRor? 104

:CALCulate:EVMQpsk:LIMit:RMS <float> 104

:CALCulate:EVMQpsk:LIMit:RMS? 104

:CALCulate:OBW:LIMit:FBLimit <freq> 116

:CALCulate:OBW:LIMit:FBLimit? 116

:CALCulate:OBW:LIMit[:TEST] OFF | ON | 0 | 1 116

:CALCulate:OBW:LIMit[:TEST]? 116

:CALCulate:OBWidth:LIMit:FBLimit <freq> 116

Commands

:CALCulate:OBWidth:LIMit:FBLimit? 116
:CALCulate:OBWidth:LIMit:STATe OFF | ON | 0 | 1 116
:CALCulate:OBWidth:LIMit:STATe? 116
:CALCulate:PCONtrol:PRACH:INTerval <float> 118
:CALCulate:PCONtrol:PRACH:INTerval? 118
:CALCulate:PCONtrol:PRACH:MLENght <float> 118
:CALCulate:PCONtrol:PRACH:MLENght? 118
:CALCulate:PCONtrol:PRACH:OFFSet <float> 118
:CALCulate:PCONtrol:PRACH:OFFSet? 118
:CALCulate:PCONtrol:PRACH:PLENght <float> 118
:CALCulate:PCONtrol:PRACH:PLENght? 119
:CALCulate:PCONtrol:SLOT:DELay <float> 119
:CALCulate:PCONtrol:SLOT:DELay? 119
:CALCulate:PCONtrol:SLOT:INTerval <float> 119
:CALCulate:PCONtrol:SLOT:INTerval? 119
:CALCulate:PCONtrol:SLOT:LENGth <float> 119
:CALCulate:PCONtrol:SLOT:LENGth? 119
:CALCulate:PCONtrol:SLOT:OFFSet <float> 120
:CALCulate:PCONtrol:SLOT:OFFSet? 120
:CALCulate:PStatistic:STORe:REFerence ON | 1 121
:CALCulate:RHO:ASET:THReshold <numeric> 122
:CALCulate:RHO:ASET:THReshold:AUTO OFF | ON | 0 | 1 122
:CALCulate:RHO:ASET:THReshold:AUTO? 122
:CALCulate:RHO:ASET:THReshold? 122
:CALCulate:RHO:IQOffset:INCLude OFF | ON | 0 | 1 122
:CALCulate:RHO:IQOffset:INCLude? 122
:CALCulate:RHO:LIMit:CDERror <float> 123
:CALCulate:RHO:LIMit:CDERror? 123
:CALCulate:RHO:LIMit:CPICH[:BTS] <float> 123
:CALCulate:RHO:LIMit:CPICH[:BTS]:POWer <float> 123
:CALCulate:RHO:LIMit:CPICH[:BTS]:POWer? 123

Commands

:CALCulate:RHO:LIMit:CPICh[:BTS]? 123

:CALCulate:RHO:LIMit:DATA[:ACTive][:LOWer] <float> 124

:CALCulate:RHO:LIMit:DATA[:ACTive][:LOWer]? 124

:CALCulate:RHO:LIMit:DATA[:ACTive][:UPPer] <float> 124

:CALCulate:RHO:LIMit:DATA[:ACTive][:UPPer]? 124

:CALCulate:RHO:LIMit:DATA[ACTive][:UPPer]dB 124

:CALCulate:RHO:LIMit:FERRor <float> 124

:CALCulate:RHO:LIMit:FERRor? 124

:CALCulate:RHO:LIMit:FREQuency <numeric> 124

:CALCulate:RHO:LIMit:FREQuency? 124

:CALCulate:RHO:LIMit:MAC:INACTive[:UPPer]<float> 125

:CALCulate:RHO:LIMit:MAC:INACTive[:UPPer]? 125

:CALCulate:RHO:LIMit:PEAK <float> 125

:CALCulate:RHO:LIMit:PEAK:MS <float> 125

:CALCulate:RHO:LIMit:PEAK:MS? 125

:CALCulate:RHO:LIMit:PEAK? 125

:CALCulate:RHO:LIMit:PHASe <float> 126

:CALCulate:RHO:LIMit:PHASe? 126

:CALCulate:RHO:LIMit:POFFset <float> 126

:CALCulate:RHO:LIMit:POFFset? 126

:CALCulate:RHO:LIMit:RHO <float> 126

:CALCulate:RHO:LIMit:RHO? 126

:CALCulate:RHO:LIMit:RMS <float> 127

:CALCulate:RHO:LIMit:RMS? 127

:CALCulate:RHO:LIMit:TIMing <float> 127

:CALCulate:RHO:LIMit:TIMing? 127

:CALCulate:RHO:PNOFFset <time> 127

:CALCulate:RHO:PNOFFset? 127

:CALCulate:RHO:TYPE ALL | DATA | MAC | PILot | PREamble 127

:CALCulate:RHO:TYPE:DATA OPSK | QAM | QPSK 128

:CALCulate:RHO:TYPE:DATA? 128

Commands

:CALCulate:RHO:TYPE? 128

:CALCulate:SPECTrum:MARKer:IQ [1] | 2 | 3 | 4? 134

:CALCulate:TCDPower:ASET:THReshold <numeric> 86

:CALCulate:TCDPower:ASET:THReshold:AUTO OFF | ON | 0 | 1 86

:CALCulate:TCDPower:ASET:THReshold:AUTO? 86

:CALCulate:TCDPower:ASET:THReshold? 86

:CALCulate:TCDPower:AXIS IPH | QPH 86

:CALCulate:TCDPower:AXIS? 86

:CALCulate:TCDPower:SWEEP:OFFSet <float> 87

:CALCulate:TCDPower:SWEEP:OFFSet? 87

:CALCulate:TCDPower:SWEEP:TIME <float> 87

:CALCulate:TCDPower:SWEEP:TIME? 87

:CALCulate:TCDPower:TYPE ABSolute | RELative 87

:CALCulate:TCDPower:TYPE? 87

:CALCulate:TCDPower:WCODe:LENGth <integer> 88

:CALCulate:TCDPower:WCODe:LENGth? 88

:CALCulate:TCDPower:WCODe:ORDer BREVerse | 88

:CALCulate:TCDPower:WCODe:ORDer? 88

:CALCulate:TCDPower:WCODe[:NUMBER] <integer> 88

:CALCulate:TCDPower:WCODe[:NUMBER]? 88

:CALCulate:TRHO:ASET:THReshold <numeric> 129

:CALCulate:TRHO:ASET:THReshold:AUTO OFF | ON | 0 | 1 129

:CALCulate:TRHO:ASET:THReshold:AUTO? 129

:CALCulate:TRHO:ASET:THReshold? 129

:CALCulate:TRHO:IQOffset:INCLude OFF | ON | 0 | 1 129

:CALCulate:TRHO:IQOffset:INCLude? 129

:CALCulate:TRHO:LIMit:ACDPower <float> 130

:CALCulate:TRHO:LIMit:ACK:GAIN <float> 130

:CALCulate:TRHO:LIMit:CDError <float> 130

:CALCulate:TRHO:LIMit:CDError? 130

:CALCulate:TRHO:LIMit:DATA:GAIN <float> 130

Commands

:CALCulate:TRHO:LIMit:DRC:GAIN <float> 131
:CALCulate:TRHO:LIMit:FERRor <float> 131
:CALCulate:TRHO:LIMit:FERRor? 131
:CALCulate:TRHO:LIMit:ICDPower <float> 131
:CALCulate:TRHO:LIMit:ICDPower? 131
:CALCulate:TRHO:LIMit:PEAK <float> 132
:CALCulate:TRHO:LIMit:PEAK? 132
:CALCulate:TRHO:LIMit:POFFset <float> 132
:CALCulate:TRHO:LIMit:POFFset? 132
:CALCulate:TRHO:LIMit:RHO <float> 132
:CALCulate:TRHO:LIMit:RHO? 132
:CALCulate:TRHO:LIMit:RMS <float> 132
:CALCulate:TRHO:LIMit:RMS? 132
:CALCulate:TRHO:LIMit:RRI <float> 133
:CALCulate:TRHO:LIMit:RRI? 133
:CALCulate:TSPur:LIMit:TEST ABSolute | RELative 135
:CALCulate:TSPur:LIMit:TEST? 135
:CALCulate:TSPur:LIMit[:UPPer][:DATA] <power> 135
:CALCulate:TSPur:LIMit[:UPPer][:DATA]? 135
:CALCulate:WAVEform:MARKer:IQ [1] | 2 | 3 | 4? 136
:CALibration:ABORt 137
:CALibration:ADC:ARANge 137
:CALibration:ADC:ARANge? 137
:CALibration:ADC:DITHer 138
:CALibration:ADC:DITHer? 138
:CALibration:ADC:OFFSet 138
:CALibration:ADC:OFFSet? 138
:CALibration:ADCRam:GAIN 138
:CALibration:ADCRam:GAIN? 138
:CALibration:ATTenuator 139
:CALibration:ATTenuator? 139

Commands

:CALibration:AUTO OFF | ALERT | ON 139
:CALibration:AUTO? 139
:CALibration:COMB 140
:CALibration:COMB? 140
:CALibration:CORRections 0 | 1 | OFF | ON 140
:CALibration:CORRections? 140
:CALibration:DISPlay:LEVel OFF | LOW | HIGH 140
:CALibration:DISPlay:LEVel? 140
:CALibration:FILTer:IMAGe 141
:CALibration:FILTer:IMAGe? 141
:CALibration:FLATness:IF 141
:CALibration:FLATness:IF? 141
:CALibration:FREQuency:REFeRence:AADJust 141
:CALibration:GADC 142
:CALibration:GADC? 142
:CALibration:GAIN:CSYSstem 142
:CALibration:GAIN:CSYSstem? 142
:CALibration:GAIN:IF 142
:CALibration:GAIN:IF? 142
:CALibration:GIF 143
:CALibration:GIF? 143
:CALibration:GIQ 143
:CALibration:GIQ? 143
:CALibration:GRF 143
:CALibration:GRF? 143
:CALibration:IQ:CMR 143
:CALibration:IQ:CMR? 143
:CALibration:IQ:FLATness 144
:CALibration:IQ:FLATness? 144
:CALibration:IQ:OFFSet 144
:CALibration:IQ:OFFSet? 144

Commands

:CALibration:LOAD:DEFault 144
:CALibration:PFILter:LC:NARRow 144
:CALibration:PFILter:LC:NARRow? 145
:CALibration:PFILter:LC:WIDE 145
:CALibration:PFILter:LC:WIDE? 145
:CALibration:PFILter:XTAL:NARRow 145
:CALibration:PFILter:XTAL:NARRow? 145
:CALibration:PFILter:XTAL:WIDE 145
:CALibration:PFILter:XTAL:WIDE? 146
:CALibration:REF321 146
:CALibration:REF321? 146
:CALibration:REF50:AMPL <power> 147
:CALibration:REF50:AMPL? 147
:CALibration:REF50:ANOW 147
:CALibration:REF50:ENTer 148
:CALibration:REF50:EXIT 148
:CALibration:REF50:LAST:ALCDac? 149
:CALibration:REF50:LAST:ALEVel? 149
:CALibration:REF50[:DOIT] 147
:CALibration:REF50[:DOIT]? 147
:CALibration:TCORrections AUTO|ON|OFF 149
:CALibration:TRIGger:DELay 150
:CALibration:TRIGger:DELay? 150
:CALibration:TRIGger:INTerpolator 150
:CALibration:TRIGger:INTerpolator? 150
:CALibration[:ALL] 138
:CALibration[:ALL]? 138
:CONFigure:<measurement> 151
:CONFigure:ACP 198
:CONFigure:AREFERENCE 206
:CONFigure:BER 207

Commands

:CONFigure:CDPower 209
:CONFigure:CHPower 225
:CONFigure:CSPur 226
:CONFigure:EEVM 227
:CONFigure:EORFspectr 230
:CONFigure:EPVTime 233
:CONFigure:ETSPur 237
:CONFigure:EVM 239
:CONFigure:EVMQpsk 246
:CONFigure:IM 249
:CONFigure:MCPower 252
:CONFigure:OBW 254
:CONFigure:ORFSpectrum 256
:CONFigure:PCONtrol 259
:CONFigure:PFERror 262
:CONFigure:PStatistic 265
:CONFigure:PVTime 267
:CONFigure:RHO 271
:CONFigure:SEMAsk 286
:CONFigure:SENSors 292
:CONFigure:SPECtrum 293
:CONFigure:TBFRequency 296
:CONFigure:TCDPower 297
:CONFigure:TRHO 301
:CONFigure:TSPur 304
:CONFigure:TXPower 305
:CONFigure:WAVEform 307
:CONFigure? 151
:DISPlay:ACP:VIEW BGRaph | SPECtrum 155
:DISPlay:ACP:VIEW? 155
:DISPlay:CDPower:BCLength 64 | 128 155

Commands

:DISPlay:CDPower:BCLength? 155
:DISPlay:CDPower:VIEW PGRaph | IQPGraph 155
:DISPlay:CDPower:VIEW PGRaph | SEVM | QUAD | DBITs 156
:DISPlay:CDPower:VIEW? 156
:DISPlay:CDPower:VIEW? 156
:DISPlay:ENABLE OFF | ON | 0 | 1 156
:DISPlay:ENABLE? 157
:DISPlay:EPVTime:LIMit:MASK OFF | ON | 0 | 1 157
:DISPlay:EPVTime:LIMit:MASK? 157
:DISPlay:EVMagnitude:VIEW POLar | CONSTln | QUAD 157
:DISPlay:EVMagnitude:VIEW? 157
:DISPlay:EVMQpsk:VIEW POLar | ERRor 158
:DISPlay:EVMQpsk:VIEW? 158
:DISPlay:FORMat:TILE 158
:DISPlay:FORMat:ZOOM 158
:DISPlay:PVTime:BURSt:STHReshold OFF | ON | 0 | 1 159
:DISPlay:PVTime:BURSt:STHReshold? 159
:DISPlay:PVTime:LIMit:MASK OFF | ON | 0 | 1 159
:DISPlay:PVTime:LIMit:MASK? 159
:DISPlay:PVTime:VIEW ALL | BOTH | A | B | C | D | E 159
:DISPlay:PVTime:VIEW? 159
:DISPlay:RHO:VIEW ERRor | POLar 160
:DISPlay:RHO:VIEW ERRor | POLar | PGRaph | TABLE 160
:DISPlay:RHO:VIEW ERRor | POLar | QUAD | TABLE | TPHase 160
:DISPlay:RHO:VIEW ERRor | POLar | TABLE 160
:DISPlay:RHO:VIEW? 160
:DISPlay:SPECTrum[n]:WINDow[m]:TRACe:Y[:SCALe]:PDIVisIon <power> 161
:DISPlay:SPECTrum[n]:WINDow[m]:TRACe:Y[:SCALe]:PDIVisIon? 161
:DISPlay:SPECTrum[n]:WINDow[m]:TRACe:Y[:SCALe]:RLEVel <power> 162
:DISPlay:SPECTrum[n]:WINDow[m]:TRACe:Y[:SCALe]:RLEVel? 162
:DISPlay:TCDPower:VIEW PGRaph | QUAD | SEVM | DBITs 163

Commands

:DISPlay:TCDPower:VIEW? 163

:DISPlay:TRACe[n][:STATe] OFF | ON | 0 | 1 163

:DISPlay:TRACe[n][:STATe]? 163

:DISPlay:WAVeform[n]:WINDow[m]:TRACe:Y[:SCALe]:PDIVision <power> 168

:DISPlay:WAVeform[n]:WINDow[m]:TRACe:Y[:SCALe]:PDIVision? 168

:DISPlay:WAVeform[n]:WINDow[m]:TRACe:Y[:SCALe]:RLEVel <power> 169

:DISPlay:WAVeform[n]:WINDow[m]:TRACe:Y[:SCALe]:RLEVel? 169

:DISPlay:WINDow[:SELEct] <number> 170

:DISPlay:WINDow[:SELEct]? 170

:DISPlay:WINDow[1] | 2 | 3 | 4:TRACe:X[:SCALe]:COUPle 0 | 1 | Off | On 170

:DISPlay:WINDow[1] | 2 | 3 | 4:TRACe:X[:SCALe]:COUPle? 170

:DISPlay:WINDow[1] | 2 | 3 | 4:TRACe:X[:SCALe]:PDIVision <number> 170

:DISPlay:WINDow[1] | 2 | 3 | 4:TRACe:X[:SCALe]:PDIVision? 170

:DISPlay:WINDow[1] | 2 | 3 | 4:TRACe:X[:SCALe]:RLEVel <number> 171

:DISPlay:WINDow[1] | 2 | 3 | 4:TRACe:X[:SCALe]:RLEVel? 171

:DISPlay:WINDow[1] | 2 | 3 | 4:TRACe:X[:SCALe]:RPOSition <number 0.0 to 10.0> 171

:DISPlay:WINDow[1] | 2 | 3 | 4:TRACe:X[:SCALe]:RPOSition? 171

:DISPlay:WINDow[1] | 2 | 3 | 4:TRACe:Y[:SCALe]:COUPle 0 | 1 | Off | On 171

:DISPlay:WINDow[1] | 2 | 3 | 4:TRACe:Y[:SCALe]:COUPle? 171

:DISPlay:WINDow[1] | 2 | 3 | 4:TRACe:Y[:SCALe]:PDIVision <number> 172

:DISPlay:WINDow[1] | 2 | 3 | 4:TRACe:Y[:SCALe]:PDIVision? 172

:DISPlay:WINDow[1] | 2 | 3 | 4:TRACe:Y[:SCALe]:RLEVel <number> 172

:DISPlay:WINDow[1] | 2 | 3 | 4:TRACe:Y[:SCALe]:RLEVel? 172

:DISPlay:WINDow[1] | 2 | 3 | 4:TRACe:Y[:SCALe]:RPOSition <number 0.0 to 10.0> 172

:DISPlay:WINDow[1] | 2 | 3 | 4:TRACe:Y[:SCALe]:RPOSition? 172

:FETCh:<measurement>[n]? 173

:FETCh:ACP[n]? 198

:FETCh:AREFERENCE[n]? 206

:FETCh:BER[n]? 207

:FETCh:CDPower[n]? 209

:FETCh:CHPower[n]? 225

Commands

[:FETCh:CSPur\[n\]? 226](#)
[:FETCh:EEVM\[n\]? 227](#)
[:FETCh:EORFspectr\[n\]? 230](#)
[:FETCh:EPVTime\[n\]? 233](#)
[:FETCh:ETSPur\[n\]? 237](#)
[:FETCh:EVM\[n\]? 239](#)
[:FETCh:EVMQpsk\[n\]? 246](#)
[:FETCh:IM\[n\]? 249](#)
[:FETCh:MCPower\[n\]? 252](#)
[:FETCh:OBW\[n\]? 254](#)
[:FETCh:ORFSpectrum\[n\]? 256](#)
[:FETCh:PCONtrol\[n\]? 259](#)
[:FETCh:PFERror\[n\]? 262](#)
[:FETCh:PSTatistic\[n\]? 265](#)
[:FETCh:PVTime\[n\]? 267](#)
[:FETCh:RHO\[n\]? 271](#)
[:FETCh:SEMask\[n\]? 286](#)
[:FETCh:SENSors\[n\]? 292](#)
[:FETCh:SPECtrum\[n\]? 293](#)
[:FETCh:TBFRequency\[n\]? 296](#)
[:FETCh:TCDPower\[n\]? 297](#)
[:FETCh:TRHO\[n\]? 301](#)
[:FETCh:TSPur\[n\]? 304](#)
[:FETCh:TXPower\[n\]? 305](#)
[:FETCh:WAVEform\[n\]? 307](#)
[:FORMat:BORDER NORMAL | SWAPped 175](#)
[:FORMat:BORDER? 175](#)
[:FORMat\[:DATA\] ASCii | REAL,32 | REAL,64 175](#)
[:FORMat\[:DATA\]? 175](#)
[:HCOPy:DESTination FPANel | PRINter 177](#)
[:HCOPy:DESTination? 177](#)

Commands

:HCOPY:DEVICE:COLOR NO | YES 177
:HCOPY:DEVICE:COLOR? 177
:HCOPY:DEVICE:LANGUAGE PCL3 | PCL5 178
:HCOPY:DEVICE:LANGUAGE? 178
:HCOPY:DEVICE[:TYPE] CUSTOM | NONE 178
:HCOPY:DEVICE[:TYPE]? 178
:HCOPY:IMAGE:COLOR[:STATE] OFF | ON | 0 | 1 178
:HCOPY:IMAGE:COLOR[:STATE]? 178
:HCOPY:ITEM:FFEED[:IMMEDIATE] 179
:HCOPY:PAGE:ORIENTATION LANDSCAPE | PORTRAIT 179
:HCOPY:PAGE:ORIENTATION? 179
:HCOPY:PAGE:PRINTS 1 | 2 180
:HCOPY:PAGE:PRINTS? 180
:HCOPY:REPRINT[:IMMEDIATE] 180
:HCOPY:SDUMP:DATA? [GIF] | BMP | WMF 180
:HCOPY:SDUMP:IMAGE NORMAL | INVERT 181
:HCOPY:SDUMP:IMAGE? 181
:HCOPY:SDUMP[:IMMEDIATE] 181
:HCOPY[:IMMEDIATE] 179
:INITIATE:<measurement> 183
:INITIATE:ACP 198
:INITIATE:REFERENCE 206
:INITIATE:BER 207
:INITIATE:CDPOWER 209
:INITIATE:CHPOWER 225
:INITIATE:CONTINUOUS OFF | ON | 0 | 1 183
:INITIATE:CONTINUOUS? 183
:INITIATE:CSPUR 226
:INITIATE:EEVM 227
:INITIATE:EORFSPECTR 230
:INITIATE:EPVTIME 233

Commands

:INITiate:ETSPur 237
:INITiate:EVM 239
:INITiate:EVMQpsk 246
:INITiate:IM 249
:INITiate:MCPower 252
:INITiate:OBW 254
:INITiate:ORFSpectrum 256
:INITiate:PFERror? 262
:INITiate:PStatistic 265
:INITiate:PVTime 267
:INITiate:REStart 184
:INITiate:RHO 271
:INITiate:SEMask 286
:INITiate:SENSors 292
:INITiate:SPECTrum 293
:INITiate:TBFrequency 296
:INITiate:TCDPower 297
:INITiate:TRHO 301
:INITiate:TSPur 304
:INITiate:TXPower 305
:INITiate:WAVEform 307
:INITiate[:IMMEDIATE] 184
:INPut:IMPedance:IQ U50ohm | B600ohm | U1Mohm | B1Mohm 185
:INPut:IMPedance:IQ? 185
:INPut:IMPedance:REFErrence <integer> 185
:INPut:IMPedance:REFErrence? 185
:INPut:IQ:ALIGn OFF | ON | 0 | 1 185
:INPut:IQ:ALIGn? 186
:INPut:OFFSet:I <level> 186
:INPut:OFFSet:I? 186
:INPut:OFFSet:Q <level> 186

Commands

:INPut:OFFSet:Q? 186

:INSTrument:CATalog[:FULL]? 189

:INSTrument:NSElect <integer> 189

:INSTrument:NSElect? 189

:INSTrument[:SElect] BASIC | SERVICE | CD-
MA | CDMA2K | GSM | EDGE GSM | IDEN | NADC | PDC |
WCDMA | CDMA1XEV 190

:INSTrument[:SElect]? 190

:MEASure:ACP[n]? 198

:MEASure:AREFERENCE[n]? 206

:MEASure:BER[n]? 207

:MEASure:CDPower[n]? 209

:MEASure:CHPower[n]? 225

:MEASure:CSPur[n]? 226

:MEASure:EEVM[n]? 227

:MEASure:EORFspectr[n]? 230

:MEASure:EPVTime[n]? 233

:MEASure:ETSPur[n]? 237

:MEASure:EVM[n]? 239

:MEASure:EVMQpsk[n]? 246

:MEASure:IM[n]? 249

:MEASure:MCPower[n]? 252

:MEASure:OBW[n]? 254

:MEASure:ORFspectrum[n]? 256

:MEASure:PCONtrol[n]? 259

:MEASure:PFERror[n]? 262

:MEASure:PSTAtastic[n]? 265

:MEASure:PVTime[n]? 267

:MEASure:RHO[n]? 271

:MEASure:SEMAsk[n]? 286

:MEASure:SENSors[n]? 292

:MEASure:SPEctrum[n]? 293

Commands

:MEASure:TBFRequency[n]? 296
:MEASure:TCDPower[n]? 297
:MEASure:TRHO[n]? 301
:MEASure:TSPur[n]? 304
:MEASure:TXPower[n]? 305
:MEASure:WAVeform[n]? 307
:MEMory:INSTall:APPLication <'filename'> 309
:MEMory:UNINStall:APPLication <'filename'> 309
:MMEMory:FREE? 311
:MMEMory:MSIS A | [C] 311
:MMEMory:MSIS? 311
:MMEMory:STORe:SCReen:FILE[:TYPE] GIF | BMP | WMF 313
:MMEMory:STORe:SCReen:IMAGe NORMAl | INVert 313
:MMEMory:STORe:SCReen:IMAGe? 313
:MMEMory:STORe:SCReen[:IMMEdiate] <filename> 312
:READ:<measurement>[n]? 315
:READ:ACP[n]? 198
:READ:AREFERENCE[n]? 206
:READ:BER[n]? 207
:READ:CDPower[n]? 209
:READ:CHPower[n]? 225
:READ:CSPur[n]? 226
:READ:EEVM[n]? 227
:READ:EORFspectr[n]? 230
:READ:EPVTime[n]? 233
:READ:ETSPur[n]? 237
:READ:EVM[n]? 239
:READ:EVMQpsk[n]? 246
:READ:IM[n]? 249
:READ:MCPower[n]? 252
:READ:OBW[n]? 254

Commands

:READ:ORFSpectrum[n]? 256
:READ:PCONtrol[n]? 259
:READ:PFERror[n]? 262
:READ:PSTatastic[n]? 265
:READ:PVTime[n]? 267
:READ:RHO[n]? 271
:READ:SEMask[n]? 286
:READ:SENSors[n]? 292
:READ:SPECtrum[n]? 293
:READ:TBFRequency[n]? 296
:READ:TCDPower[n]? 297
:READ:TRHO[n]? 301
:READ:TSPur[n]? 304
:READ:TXPower[n]? 305
:READ:WAVEform[n]? 307
:SENSe]:EPVTime:PCLevel? 400
:STATus:OPERation:CONDition? 575
:STATus:OPERation:ENABLE <integer> 575
:STATus:OPERation:ENABLE? 575
:STATus:OPERation:NTRansition <integer> 576
:STATus:OPERation:NTRansition? 576
:STATus:OPERation:PTRansition <integer> 576
:STATus:OPERation:PTRansition? 576
:STATus:OPERation[:EVENT]? 575
:STATus:PRESet 576
:STATus:QUEStionable:CALibration:CONDition? 578
:STATus:QUEStionable:CALibration:ENABLE <number> 579
:STATus:QUEStionable:CALibration:ENABLE? 579
:STATus:QUEStionable:CALibration:NTRansition <number> 579
:STATus:QUEStionable:CALibration:NTRansition? 579
:STATus:QUEStionable:CALibration:PTRansition <number> 580

Commands

:STATus:QUEStionable:CALibration:PTRansition? 580
:STATus:QUEStionable:CALibration[:EVENT]? 579
:STATus:QUEStionable:CONDition? 577
:STATus:QUEStionable:ENABle <number> 577
:STATus:QUEStionable:ENABle? 577
:STATus:QUEStionable:FREQuency:CONDition? 580
:STATus:QUEStionable:FREQuency:ENABle <number> 580
:STATus:QUEStionable:FREQuency:ENABle? 580
:STATus:QUEStionable:FREQuency:NTRansition <number> 581
:STATus:QUEStionable:FREQuency:NTRansition? 581
:STATus:QUEStionable:FREQuency:PTRansition <number> 581
:STATus:QUEStionable:FREQuency:PTRansition? 581
:STATus:QUEStionable:FREQuency[:EVENT]? 581
:STATus:QUEStionable:INTEgrity:CONDition? 582
:STATus:QUEStionable:INTEgrity:ENABle <number> 582
:STATus:QUEStionable:INTEgrity:ENABle? 582
:STATus:QUEStionable:INTEgrity:NTRansition <number> 582
:STATus:QUEStionable:INTEgrity:NTRansition? 583
:STATus:QUEStionable:INTEgrity:PTRansition <number> 583
:STATus:QUEStionable:INTEgrity:PTRansition? 583
:STATus:QUEStionable:INTEgrity:SIGNAL:CONDition? 583
:STATus:QUEStionable:INTEgrity:SIGNAL:ENABle <number> 583
:STATus:QUEStionable:INTEgrity:SIGNAL:ENABle? 583
:STATus:QUEStionable:INTEgrity:SIGNAL:NTRansition <number> 584
:STATus:QUEStionable:INTEgrity:SIGNAL:NTRansition? 584
:STATus:QUEStionable:INTEgrity:SIGNAL:PTRansition <number> 584
:STATus:QUEStionable:INTEgrity:SIGNAL:PTRansition? 584
:STATus:QUEStionable:INTEgrity:SIGNAL[:EVENT]? 584
:STATus:QUEStionable:INTEgrity:UNCalibrated:CONDition? 585
:STATus:QUEStionable:INTEgrity:UNCalibrated:ENABle 585
:STATus:QUEStionable:INTEgrity:UNCalibrated:ENABle? 585

Commands

:STATus:QUEStionable:INTEGRity:UNCalibrated:NTRansition <number> 586
:STATus:QUEStionable:INTEGRity:UNCalibrated:NTRansition? 586
:STATus:QUEStionable:INTEGRity:UNCalibrated:PTRansition <number> 586
:STATus:QUEStionable:INTEGRity:UNCalibrated:PTRansition? 586
:STATus:QUEStionable:INTEGRity:UNCalibrated[:EVENT]? 585
:STATus:QUEStionable:INTEGRity[:EVENT]? 582
:STATus:QUEStionable:NTRansition <number> 578
:STATus:QUEStionable:NTRansition? 578
:STATus:QUEStionable:POWer:CONDition? 586
:STATus:QUEStionable:POWer:ENABLE <number> 587
:STATus:QUEStionable:POWer:ENABLE? 587
:STATus:QUEStionable:POWer:NTRansition <number> 587
:STATus:QUEStionable:POWer:NTRansition? 587
:STATus:QUEStionable:POWer:PTRansition <number> 588
:STATus:QUEStionable:POWer:PTRansition?> 588
:STATus:QUEStionable:POWer[:EVENT]? 587
:STATus:QUEStionable:PTRansition <number> 578
:STATus:QUEStionable:PTRansition? 578
:STATus:QUEStionable:TEMPerature:CONDition? 588
:STATus:QUEStionable:TEMPerature:ENABLE <number> 588
:STATus:QUEStionable:TEMPerature:ENABLE? 588
:STATus:QUEStionable:TEMPerature:NTRansition <number> 589
:STATus:QUEStionable:TEMPerature:NTRansition? 589
:STATus:QUEStionable:TEMPerature:PTRansition <number> 589
:STATus:QUEStionable:TEMPerature:PTRansition? 589
:STATus:QUEStionable:TEMPerature[:EVENT]? 589
:STATus:QUEStionable[:EVENT]? 577
:SYSTem:COMMunicate:GPIB[:SELF]:ADDRess <integer> 591
:SYSTem:COMMunicate:GPIB[:SELF]:ADDRess? 591
:SYSTem:COMMunicate:LAN[:SELF]:IP <string> 591
:SYSTem:COMMunicate:LAN[:SELF]:IP? 591

Commands

`:SYSTem:CONFigure:DEFault` 592
`:SYSTem:DATE <year>,<month>,<day>` 592
`:SYSTem:DATE?` 592
`:SYSTem:ERRor:VERBose OFF | ON | 0 | 1` 593
`:SYSTem:ERRor:VERBose?` 593
`:SYSTem:ERRor[:NEXT]?` 592
`:SYSTem:EXIT` 593
`:SYSTem:HID?` 594
`:SYSTem:KLOCK OFF | ON | 0 | 1` 594
`:SYSTem:KLOCK?` 594
`:SYSTem:LKEY <'option'>,<'license key'>` 594
`:SYSTem:LKEY:DELete <'application option'>,<'license key'>` 595
`:SYSTem:LKEY? <'option'>` 594
`:SYSTem:MESSage <string>` 595
`:SYSTem:MESSage:OFF` 596
`:SYSTem:PASSword[:CENable]<integer>` 596
`:SYSTem:PRESet` 596
`:SYSTem:TIME <hour>,<min>,<sec>` 596
`:SYSTem:TIME:ADJust <seconds>` 597
`:SYSTem:TIME?` 596
`:SYSTem:VERSion?` 597
`:TRIGger[:SEQuence]:AUTO:STATe OFF | ON | 0 | 1` 599
`:TRIGger[:SEQuence]:AUTO:STATe?` 599
`:TRIGger[:SEQuence]:AUTO[:TIME] <time>` 599
`:TRIGger[:SEQuence]:AUTO[:TIME]?` 599
`:TRIGger[:SEQuence]:EXTernal[1] | 2:DELay <time>` 600
`:TRIGger[:SEQuence]:EXTernal[1] | 2:DELay?` 600
`:TRIGger[:SEQuence]:EXTernal[1] | 2:LEVel <voltage>` 600
`:TRIGger[:SEQuence]:EXTernal[1] | 2:LEVel?` 600
`:TRIGger[:SEQuence]:EXTernal[1] | 2:SLOPe NEGative | POSitive` 600
`:TRIGger[:SEQuence]:EXTernal[1] | 2:SLOPe?` 600

Commands

:TRIGger[:SEQuence]:FRAMe:ADJust <time> 601
:TRIGger[:SEQuence]:FRAMe:PERiod <time> 601
:TRIGger[:SEQuence]:FRAMe:PERiod? 601
:TRIGger[:SEQuence]:FRAMe:SYNC EXTFront | EXTReAr | OFF 602
:TRIGger[:SEQuence]:FRAMe:SYNC:OFFSet <time> 602
:TRIGger[:SEQuence]:FRAMe:SYNC:OFFSet? 602
:TRIGger[:SEQuence]:FRAMe:SYNC? 602
:TRIGger[:SEQuence]:HOLDoff <time> 602
:TRIGger[:SEQuence]:HOLDoff? 602
:TRIGger[:SEQuence]:IF:DELay <time> 603
:TRIGger[:SEQuence]:IF:DELay? 603
:TRIGger[:SEQuence]:IF:LEVel <ampl> 603
:TRIGger[:SEQuence]:IF:LEVel? 603
:TRIGger[:SEQuence]:IF:SLOPe NEGative | POSitive 604
:TRIGger[:SEQuence]:IF:SLOPe? 604
:TRIGger[:SEQuence]:RFBurst:DELay <time> 604
:TRIGger[:SEQuence]:RFBurst:DELay? 604
:TRIGger[:SEQuence]:RFBurst:LEVel <rel_power> 604
:TRIGger[:SEQuence]:RFBurst:LEVel? 604
:TRIGger[:SEQuence]:RFBurst:SLOPe NEGative | POSitive 605
:TRIGger[:SEQuence]:RFBurst:SLOPe? 605
[:SENSe]:ACP:AVERage:COUNT <integer> 317
[:SENSe]:ACP:AVERage:COUNT? 317
[:SENSe]:ACP:AVERage:TCONtrol EXPonential | REPeat 318
[:SENSe]:ACP:AVERage:TCONtrol? 318
[:SENSe]:ACP:AVERage:TYPE MAXimum | RMS 318
[:SENSe]:ACP:AVERage:TYPE? 318
[:SENSe]:ACP:AVERage[:STATe] OFF | ON | 0 | 1 317
[:SENSe]:ACP:AVERage[:STATe]? 317
[:SENSe]:ACP:BANDwidth[n] | BWIDth[n]:INTegration <freq> 319
[:SENSe]:ACP:BANDwidth[n] | BWIDth[n]:INTegration? 319

Commands

[[:SENSe]:ACP:BANDwidth[n] | BWIDth[n]:INTegration[m] <freq> 319
[:SENSe]:ACP:BANDwidth[n] | BWIDth[n]:INTegration[m]? 319
[:SENSe]:ACP:BANDwidth | BWIDth:INTegration <freq> 318
[:SENSe]:ACP:BANDwidth | BWIDth:INTegration? 318
[:SENSe]:ACP:DYNAmic[n]:RANGe[m] HIGH | NORMAl | MODified 319
[:SENSe]:ACP:DYNAmic[n]:RANGe[m]? 320
[:SENSe]:ACP:FAST:OFFSet:ADC:RANGe? 320
[:SENSe]:ACP:FAST:OFFSet:ADC:RANGe
AUTO | APEak | APLock | M6 | P0 | P6 | P12 | P18 | P24 320
[:SENSe]:ACP:FAST:OFFSet:ADC:RANGe
AUTO | APEak | APLock | NONE | P0 | P6 | P12 | P18 320
[:SENSe]:ACP:FAST:OFFSet:RATTenuation <rel power> 321
[:SENSe]:ACP:FAST:OFFSet:RATTenuation? 321
[:SENSe]:ACP:FFTSegment <integer> 322
[:SENSe]:ACP:FFTSegment:AUTO OFF | ON | 0 | 1 322
[:SENSe]:ACP:FFTSegment:AUTO? 322
[:SENSe]:ACP:FFTSegment? 322
[:SENSe]:ACP:FILTer[:RRC]:ALPHa <numeric> 321
[:SENSe]:ACP:FILTer[:RRC]:ALPHa? 321
[:SENSe]:ACP:FILTer[:RRC][:STATe] OFF | ON | 0 | 1 322
[:SENSe]:ACP:FILTer[:RRC][:STATe]? 322
[:SENSe]:ACP:FREQuency:SPAN? 323
[:SENSe]:ACP:LIST:ALIMit <abs_powr>,<abs_powr>,<abs_powr>,<abs_powr>,<abs_powr> 323
[:SENSe]:ACP:LIST:ALIMit? 323
[:SENSe]:ACP:LIST:POWer INTeg | PEAK,INTeg | PEAK,INTeg | PEAK,INTeg | PEAK,IN-
Teg | PEAK 324
[:SENSe]:ACP:LIST:POWer? 324
[:SENSe]:ACP:LIST:RLIMit <rel_powr>,<rel_powr>,<rel_powr>,<rel_powr>,<rel_powr> 324
[:SENSe]:ACP:LIST:RLIMit? 324
[:SENSe]:ACP:LIST:STATe OFF | ON | 0 | 1, OFF | ON | 0 | 1, OFF | ON | 0 | 1, OFF | ON | 0 | 1,
OFF | ON | 0 | 1 325
[:SENSe]:ACP:LIST:STATe? 325

Commands

[[:SENSe]:ACP:LIST:TEST ABSolute | AND | RELative | OR,
ABSolute | AND | RELative | OR, ABSolute | AND | RELative | OR,
ABSolute | AND | RELative | OR, ABSolute | AND | RELative | OR 325

[[:SENSe]:ACP:LIST:TEST? 325

[[:SENSe]:ACP:LIST[:FREQuency] <f_offset>,<f_offset>,<f_offset>,<f_offset>,<f_offset> 323

[[:SENSe]:ACP:LIST[:FREQuency]? 323

[[:SENSe]:ACP:OFFSet:ABSolute <power> 325

[[:SENSe]:ACP:OFFSet:ABSolute? 325

[[:SENSe]:ACP:OFFSet:BANDwidth | BWIDth <res_bw> 327

[[:SENSe]:ACP:OFFSet:BANDwidth | BWIDth? 327

[[:SENSe]:ACP:OFFSet:LIST:ABSolute <power>,<power>,<power>,<power>,<power> 325

[[:SENSe]:ACP:OFFSet:LIST:ABSolute? 325

[[:SENSe]:ACP:OFFSet:LIST:AVERAge:TYPE MAXimum | RMS 326

[[:SENSe]:ACP:OFFSet:LIST:AVERAge:TYPE? 327

[[:SENSe]:ACP:OFFSet:LIST:BANDwidth | BWIDth
<res_bw>,<res_bw>,<res_bw>,<res_bw>,<res_bw> 327

[[:SENSe]:ACP:OFFSet:LIST:BANDwidth | BWIDth? 327

[[:SENSe]:ACP:OFFSet:LIST:FFTSegment <integer>,<integer>,<integer>,<integer>,<integer> 328

[[:SENSe]:ACP:OFFSet:LIST:FFTSegment:AUTO OFF | ON | 0 | 1,
OFF | ON | 0 | 1, OFF | ON | 0 | 1, OFF | ON | 0 | 1, OFF | ON | 0 | 1 329

[[:SENSe]:ACP:OFFSet:LIST:FFTSegment:AUTO? 329

[[:SENSe]:ACP:OFFSet:LIST:FFTSegment? 328

[[:SENSe]:ACP:OFFSet:LIST:POINts <integer>,<integer>,<integer>,<integer>,<integer> 331

[[:SENSe]:ACP:OFFSet:LIST:POINts:AUTO OFF | ON | 0 | 1, OFF | ON | 0 | 1, OFF | ON | 0 | 1,
OFF | ON | 0 | 1, OFF | ON | 0 | 1 331

[[:SENSe]:ACP:OFFSet:LIST:POINts:AUTO? 331

[[:SENSe]:ACP:OFFSet:LIST:POINts? 331

[[:SENSe]:ACP:OFFSet:LIST:RATTenuation:AUTO OFF | ON | 0 | 1 333

[[:SENSe]:ACP:OFFSet:LIST:RATTenuation:AUTO? 333

[[:SENSe]:ACP:OFFSet:LIST:RATTenuation
<rel_powr>,<rel_powr>,<rel_powr>,<rel_powr>,<rel_powr> 332

[[:SENSe]:ACP:OFFSet:LIST:RATTenuation? 332

[[:SENSe]:ACP:OFFSet:LIST:RCARrier
<rel_power>,<rel_power>,<rel_power>,<rel_power>,<rel_power> 333

Commands

[[:SENSE]:ACP:OFFSet:LIST:RCARrier? 333

[[:SENSE]:ACP:OFFSet:LIST:RPSDensity
<rel_power>,<rel_power>,<rel_power>,<rel_power>,<rel_power> 335

[[:SENSE]:ACP:OFFSet:LIST:RPSDensity? 335

[[:SENSE]:ACP:OFFSet:LIST:SIDE BOTH | NEGative | POSitive,
BOTH | NEGative | POSitive, BOTH | NEGative | POSitive, BOTH | NEGative | POSitive,
BOTH | NEGative | POSitive 336

[[:SENSE]:ACP:OFFSet:LIST:SIDE? 336

[[:SENSE]:ACP:OFFSet:LIST:STATe OFF | ON | 0 | 1, OFF | ON | 0 | 1,
OFF | ON | 0 | 1, OFF | ON | 0 | 1, OFF | ON | 0 | 1 336

[[:SENSE]:ACP:OFFSet:LIST:STATe? 336

[[:SENSE]:ACP:OFFSet:LIST:SWEep:TIME <seconds>,<seconds>,<seconds>,<seconds>,<seconds>
337

[[:SENSE]:ACP:OFFSet:LIST:SWEep:TIME:AUTO OFF | ON | 0 | 1,
OFF | ON | 0 | 1, OFF | ON | 0 | 1, OFF | ON | 0 | 1, OFF | ON | 0 | 1 338

[[:SENSE]:ACP:OFFSet:LIST:SWEep:TIME:AUTO? 338

[[:SENSE]:ACP:OFFSet:LIST:SWEep:TIME? 337

[[:SENSE]:ACP:OFFSet:LIST:TEST ABSolute | AND | OR | RELative,
ABSolute | AND | OR | RELative, ABSolute | AND | OR | RELative, ABSolute | AND | OR | RELative,
ABSolute | AND | OR | RELative 339

[[:SENSE]:ACP:OFFSet:LIST:TEST? 339

[[:SENSE]:ACP:OFFSet:LIST[:FREQuency]
<f_offset>,<f_offset>,<f_offset>,<f_offset>,<f_offset> 329

[[:SENSE]:ACP:OFFSet:LIST[:FREQuency]? 330

[[:SENSE]:ACP:OFFSet:RCARrier <rel_power> 333

[[:SENSE]:ACP:OFFSet:RCARrier? 333

[[:SENSE]:ACP:OFFSet:RPSDensity <rel_power> 334

[[:SENSE]:ACP:OFFSet:RPSDensity? 334

[[:SENSE]:ACP:OFFSet:TEST ABSolute | AND | OR | RELative 338

[[:SENSE]:ACP:OFFSet:TEST? 339

[[:SENSE]:ACP:OFFSet[:FREQuency] <f_offset> 329

[[:SENSE]:ACP:OFFSet[:FREQuency]? 329

[[:SENSE]:ACP:OFFSet[n]:LIST:ABSolute
<power>,<power>,<power>,<power>,<power> 326

[[:SENSE]:ACP:OFFSet[n]:LIST:ABSolute? 326

Commands

[[:SENSe]:ACP:OFFSet[n]:LIST:BANDwidth | BWIDth
<res_bw>,<res_bw>,<res_bw>,<res_bw>,<res_bw> 327

[[:SENSe]:ACP:OFFSet[n]:LIST:BANDwidth | BWIDth? 327

[[:SENSe]:ACP:OFFSet[n]:LIST:RCARrier
<rel_power>,<rel_power>,<rel_power>,<rel_power>,<rel_power> 333

[[:SENSe]:ACP:OFFSet[n]:LIST:RCARrier? 333

[[:SENSe]:ACP:OFFSet[n]:LIST:RPSDensity
<rel_power>,<rel_power>,<rel_power>,<rel_power>,<rel_power> 335

[[:SENSe]:ACP:OFFSet[n]:LIST:RPSDensity? 335

[[:SENSe]:ACP:OFFSet[n]:LIST:STATe OFF | ON | 0 | 1, OFF | ON | 0 | 1,
OFF | ON | 0 | 1, OFF | ON | 0 | 1, OFF | ON | 0 | 1 336

[[:SENSe]:ACP:OFFSet[n]:LIST:STATe? 336

[[:SENSe]:ACP:OFFSet[n]:LIST:TEST ABSolute | AND | OR | RELative,
ABSolute | AND | OR | RELative, ABSolute | AND | OR | RELative, ABSolute | AND | OR | RELative,
ABSolute | AND | OR | RELative 339

[[:SENSe]:ACP:OFFSet[n]:LIST:TEST? 339

[[:SENSe]:ACP:OFFSet[n]:LIST[:FREQuency]
<f_offset>,<f_offset>,<f_offset>,<f_offset>,<f_offset> 330

[[:SENSe]:ACP:OFFSet[n]:LIST[:FREQuency]? 330

[[:SENSe]:ACP:OFFSet[n]:LIST[n]:BANDwidth | BWIDth
<res_bw>,<res_bw>,<res_bw>,<res_bw>,<res_bw> 327

[[:SENSe]:ACP:OFFSet[n]:LIST[n]:BANDwidth | BWIDth? 327

[[:SENSe]:ACP:OFFSet[n]:LIST[n]:RCARrier
<rel_power>,<rel_power>,<rel_power>,<rel_power>,<rel_power> 333

[[:SENSe]:ACP:OFFSet[n]:LIST[n]:RCARrier? 333

[[:SENSe]:ACP:OFFSet[n]:LIST[n]:RPSDensity
<rel_power>,<rel_power>,<rel_power>,<rel_power>,<rel_power> 335

[[:SENSe]:ACP:OFFSet[n]:LIST[n]:RPSDensity? 335

[[:SENSe]:ACP:OFFSet[n]:LIST[n]:STATe OFF | ON | 0 | 1,
OFF | ON | 0 | 1, OFF | ON | 0 | 1, OFF | ON | 0 | 1, OFF | ON | 0 | 1 337

[[:SENSe]:ACP:OFFSet[n]:LIST[n]:STATe? 337

[[:SENSe]:ACP:OFFSet[n]:LIST[n]:TEST, ABSolute | AND | OR | RELative,
ABSolute | AND | OR | RELative, ABSolute | AND | OR | RELative, ABSolute | AND | OR | RELative
339

[[:SENSe]:ACP:OFFSet[n]:LIST[n]:TEST? 339

[[:SENSe]:ACP:OFFSet[n]:LIST[n]:FREQuency]

Commands

<f_offset>,<f_offset>,<f_offset>,<f_offset>,<f_offset> 330

[[:SENSe]:ACP:OFFSet[n]:LIST[n]:FREQuency]? 330

[[:SENSe]:ACP:POINts <integer> 340

[[:SENSe]:ACP:POINts:AUTO OFF | ON | 0 | 1 341

[[:SENSe]:ACP:POINts:AUTO? 341

[[:SENSe]:ACP:POINts? 340

[[:SENSe]:ACP:SPECtrum:ENABle OFF | ON | 0 | 1 341

[[:SENSe]:ACP:SPECtrum:ENABle? 341

[[:SENSe]:ACP:SWEep:BANDwidth | BWIDth[:RESolution] <freq> 341

[[:SENSe]:ACP:SWEep:BANDwidth | BWIDth[:RESolution]:AUTO OFF | ON | 0 | 1 342

[[:SENSe]:ACP:SWEep:BANDwidth | BWIDth[:RESolution]:AUTO? 342

[[:SENSe]:ACP:SWEep:BANDwidth | BWIDth[:RESolution]? 341

[[:SENSe]:ACP:SWEep:DETEctor[:FUNction] AAverage | POSitive 342

[[:SENSe]:ACP:SWEep:DETEctor[:FUNction]? 342

[[:SENSe]:ACP:SWEep:TIME <seconds> 342

[[:SENSe]:ACP:SWEep:TIME:AUTO OFF | ON | 0 | 1 343

[[:SENSe]:ACP:SWEep:TIME:AUTO? 343

[[:SENSe]:ACP:SWEep:TIME? 342

[[:SENSe]:ACP:SWEep:TYPE FAST | FFT | SWEep 343

[[:SENSe]:ACP:SWEep:TYPE FFT | SWEep 343

[[:SENSe]:ACP:SWEep:TYPE? 343

[[:SENSe]:ACP:SWEep:TYPE? 343

[[:SENSe]:ACP:TRIGger:SOURce EXTernal[1] | EXTernal2 | FRAME | IF | IMMEDIATE | RFBurst 344

[[:SENSe]:ACP:TRIGger:SOURce? 344

[[:SENSe]:ACP:TYPE PSDRef | TPreF 345

[[:SENSe]:ACP:TYPE? 345

[[:SENSe]:CDPower:ACODE AUTO | PREDefined 347

[[:SENSe]:CDPower:ACODE? 347

[[:SENSe]:CDPower:ADC:RANGe AUTO | APEak | APLock | M6 | P0 | P6 | P12 | P18 | P24 347

[[:SENSe]:CDPower:ADC:RANGe AUTO | APEak | APLock | NONE | P0 | P6 | P12 | P18 347

[[:SENSe]:CDPower:ADC:RANGe? 347

Commands

[[:SENSe]:CDPower:ALPHa <numeric> 348
[:SENSe]:CDPower:ALPHa? 348
[:SENSe]:CDPower:ASET:THReshold <rel_power> 350
[:SENSe]:CDPower:ASET:THReshold? 350
[:SENSe]:CDPower:AVERAge:COUNt <integer> 349
[:SENSe]:CDPower:AVERAge:COUNt? 349
[:SENSe]:CDPower:AVERAge:TCONtrol EXPonential | REPeat 349
[:SENSe]:CDPower:AVERAge:TCONtrol? 349
[:SENSe]:CDPower:AVERAge[:STATe] OFF | ON | 0 | 1 349
[:SENSe]:CDPower:AVERAge[:STATe]? 349
[:SENSe]:CDPower:CAPTure:TIME <numeric> 350
[:SENSe]:CDPower:CAPTure:TIME? 350
[:SENSe]:CDPower:CRATe <freq> 351
[:SENSe]:CDPower:CRATe? 351
[:SENSe]:CDPower:METHod FPOWER | POWER | TPHase 351
[:SENSe]:CDPower:METHod? 351
[:SENSe]:CDPower:PILot:COMPensation[:STATe] OFF | ON | 0 | 1 351
[:SENSe]:CDPower:PILot:COMPensation[:STATe]? 351
[:SENSe]:CDPower:PNOFfset <integer> 352
[:SENSe]:CDPower:PNOFfset? 352
[:SENSe]:CDPower:PRACH:SIGNature <integer> 352
[:SENSe]:CDPower:PRACH:SIGNature:AUTO OFF | ON | 0 | 1 352
[:SENSe]:CDPower:PRACH:SIGNature:AUTO? 352
[:SENSe]:CDPower:PRACH:SIGNature? 352
[:SENSe]:CDPower:PREamble:LENGth <integer> 353
[:SENSe]:CDPower:PREamble:LENGth:AUTO OFF | ON | 0 | 1 353
[:SENSe]:CDPower:PREamble:LENGth:AUTO? 353
[:SENSe]:CDPower:PREamble:LENGth? 353
[:SENSe]:CDPower:QOF 0 | 1 | 2 | 3 353
[:SENSe]:CDPower:QOF? 353
[:SENSe]:CDPower:SBOundary? 354

Commands

[[:SENSe]:CDPower:SBOundary[:BTS] AU-
TO | MAX | TM1D16 | TM1D32 | TM1D64 | TM2 | TM3D16 | TM3D32 | TM4 | TM4CP |
TM1D16SC | TM1D32SC | TM1D64SC | TM2SC | TM3D16SC | TM3D32SC 353

[[:SENSe]:CDPower:SFORmat:MS 356

[[:SENSe]:CDPower:SFORmat:MS 356

[[:SENSe]:CDPower:SFORmat:MS SF0 | SF1 | SF2 | SF3 | SF4 | SF5 355

[[:SENSe]:CDPower:SFORmat:MS? 355

[[:SENSe]:CDPower:SPECtrum INVert | NORMal 355

[[:SENSe]:CDPower:SPECtrum? 355

[[:SENSe]:CDPower:SWEep:TIME <time> 355

[[:SENSe]:CDPower:SWEep:TIME? 355

[[:SENSe]:CDPower:SYNC:LCMask <integer> 356

[[:SENSe]:CDPower:SYNC:LCMask? 356

[[:SENSe]:CDPower:SYNC:MS DPCCh | PMESsage 356

[[:SENSe]:CDPower:SYNC:MS? 356

[[:SENSe]:CDPower:SYNC:SCRamble:MS <integer> 358

[[:SENSe]:CDPower:SYNC:SCRamble:MS? 358

[[:SENSe]:CDPower:SYNC:SCRamble[:BTS] <integer> 357

[[:SENSe]:CDPower:SYNC:SCRamble[:BTS]:OFFSet <integer> 357

[[:SENSe]:CDPower:SYNC:SCRamble[:BTS]:OFFSet? 357

[[:SENSe]:CDPower:SYNC:SCRamble[:BTS]:TYPE LEFT | RIGHT | STANdard 357

[[:SENSe]:CDPower:SYNC:SCRamble[:BTS]:TYPE? 357

[[:SENSe]:CDPower:SYNC:SCRamble[:BTS]? 357

[[:SENSe]:CDPower:SYNC:SYMBOL:SPRead <integer> 358

[[:SENSe]:CDPower:SYNC:SYMBOL:SPRead? 358

[[:SENSe]:CDPower:SYNC:SYMBOL:SRATe <integer> 359

[[:SENSe]:CDPower:SYNC:SYMBOL:SRATe? 359

[[:SENSe]:CDPower:SYNC[:BTS] CPICH | SCH | SYMBOL | A2CPich 356

[[:SENSe]:CDPower:SYNC[:BTS]? 356

[[:SENSe]:CDPower:TRIGger:SOURce EXTernal[1] | External2 | FRAME | IF | IMMEDIATE | RFBurst
359

[[:SENSe]:CDPower:TRIGger:SOURce? 359

Commands

[:SENSe]:CHANnel:ARFCn | RFCHannel <integer> 360
[:SENSe]:CHANnel:ARFCn | RFCHannel:BOTTom 360
[:SENSe]:CHANnel:ARFCn | RFCHannel:MIDDle 361
[:SENSe]:CHANnel:ARFCn | RFCHannel:TOP 362
[:SENSe]:CHANnel:ARFCn | RFCHannel? 360
[:SENSe]:CHANnel:BURSt NORMal | SYNC | ACCess 363
[:SENSe]:CHANnel:BURSt TCH | CCH 362
[:SENSe]:CHANnel:BURSt? 362
[:SENSe]:CHANnel:BURSt? 363
[:SENSe]:CHANnel:PNOFfset <integer> 363
[:SENSe]:CHANnel:PNOFfset? 363
[:SENSe]:CHANnel:SLOT <integer> 363
[:SENSe]:CHANnel:SLOT:AUTO OFF | ON | 0 | 1 364
[:SENSe]:CHANnel:SLOT:AUTO? 364
[:SENSe]:CHANnel:SLOT? 363
[:SENSe]:CHANnel:TSCode <integer> 364
[:SENSe]:CHANnel:TSCode:AUTO OFF | ON | 0 | 1 365
[:SENSe]:CHANnel:TSCode:AUTO? 365
[:SENSe]:CHANnel:TSCode? 364
[:SENSe]:CHPower:AVERage:COUNt <integer> 366
[:SENSe]:CHPower:AVERage:COUNt? 366
[:SENSe]:CHPower:AVERage:TCONtrol EXPonential | REPeat 366
[:SENSe]:CHPower:AVERage:TCONtrol? 366
[:SENSe]:CHPower:AVERage[:STATe] OFF | ON | 0 | 1 366
[:SENSe]:CHPower:AVERage[:STATe]? 366
[:SENSe]:CHPower:BANDwidth | BWIDth:INTegration <freq> 367
[:SENSe]:CHPower:BANDwidth | BWIDth:INTegration? 367
[:SENSe]:CHPower:FREQuency:SPAN <freq> 367
[:SENSe]:CHPower:FREQuency:SPAN? 367
[:SENSe]:CHPower:POINts <integer> 367
[:SENSe]:CHPower:POINts:AUTO OFF | ON | 0 | 1 368

Commands

[:SENSe]:CHPower:POINts:AUTO? 368
[:SENSe]:CHPower:POINts? 368
[:SENSe]:CHPower:SWEep:TIME <time> 368
[:SENSe]:CHPower:SWEep:TIME:AUTO OFF | ON | 0 | 1 369
[:SENSe]:CHPower:SWEep:TIME:AUTO? 369
[:SENSe]:CHPower:SWEep:TIME? 368
[:SENSe]:CHPower:TRIGger:SOURce EXTernal[1] | EXTernal2 | IMMEDIATE 369
[:SENSe]:CHPower:TRIGger:SOURce? 369
[:SENSe]:CORRection:BS[:RF]:LOSS <rel_power> 370
[:SENSe]:CORRection:BS[:RF]:LOSS? 370
[:SENSe]:CORRection:BTS[:RF]:LOSS <rel_power> 370
[:SENSe]:CORRection:BTS[:RF]:LOSS? 370
[:SENSe]:CORRection:MS[:RF]:LOSS <rel_power> 370
[:SENSe]:CORRection:MS[:RF]:LOSS? 370
[:SENSe]:CORRection[:RF]:LOSS <rel_power> 371
[:SENSe]:CORRection[:RF]:LOSS? 371
[:SENSe]:CSPur:AVERAge:COUNT <integer> 372
[:SENSe]:CSPur:AVERAge:COUNT? 372
[:SENSe]:CSPur:AVERAge:TCONtrol EXPONential | REPeat 372
[:SENSe]:CSPur:AVERAge:TCONtrol? 372
[:SENSe]:CSPur:AVERAge:TYPE LOG | MAXimum | RMS | SCALar 373
[:SENSe]:CSPur:AVERAge:TYPE? 373
[:SENSe]:CSPur:AVERAge[:STATe] OFF | ON | 0 | 1 372
[:SENSe]:CSPur:AVERAge[:STATe]? 372
[:SENSe]:CSPur:TYPE EXAMine | FULL 373
[:SENSe]:CSPur:TYPE? 373
[:SENSe]:EEVM:AVERAge:COUNT <integer> 375
[:SENSe]:EEVM:AVERAge:COUNT? 375
[:SENSe]:EEVM:AVERAge:TCONtrol EXPONential | REPeat 375
[:SENSe]:EEVM:AVERAge:TCONtrol? 375
[:SENSe]:EEVM:AVERAge[:STATe] OFF | ON | 0 | 1 375

Commands

[[:SENSe]:EEVM:AVERage[:STATe]? 375
[:SENSe]:EEVM:BSYNc:SOURce RFBurst | TSEQuence | NONE 376
[:SENSe]:EEVM:BSYNc:SOURce? 376
[:SENSe]:EEVM:DROop OFF | ON | 0 | 1 376
[:SENSe]:EEVM:DROop? 376
[:SENSe]:EEVM:ELIMit OFF | ON | 0 | 1 377
[:SENSe]:EEVM:ELIMit? 377
[:SENSe]:EEVM:SDOTs OFF | ON | 0 | 1 377
[:SENSe]:EEVM:SDOTs? 377
[:SENSe]:EEVM:TRACe:SDOTs <integer> 377
[:SENSe]:EEVM:TRACe:SDOTs? 377
[:SENSe]:EEVM:TRIGger:SOURce EXTernal[1] | EXTernal2 | FRAME | IF | IMMEDIATE | RFBurst 378
[:SENSe]:EEVM:TRIGger:SOURce? 378
[:SENSe]:EORFspectr:AVERage:COUNT <integer> 379
[:SENSe]:EORFspectr:AVERage:COUNT? 379
[:SENSe]:EORFspectr:AVERage:FAST[:STATe] OFF | ON | 0 | 1 379
[:SENSe]:EORFspectr:AVERage:FAST[:STATe]? 379
[:SENSe]:EORFspectr:AVERage:MODulation:TYPE LOG | RMS 380
[:SENSe]:EORFspectr:AVERage:MODulation:TYPE? 380
[:SENSe]:EORFspectr:AVERage[:STATe] OFF | ON | 0 | 1 380
[:SENSe]:EORFspectr:AVERage[:STATe]? 380
[:SENSe]:EORFspectr:BANDwidth | BWIDth[:RESolution]
:MODulation:CARRier <freq> 380
[:SENSe]:EORFspectr:BANDwidth | BWIDth[:RESolution]
:MODulation:CARRier? 380
[:SENSe]:EORFspectr:BANDwidth | BWIDth[:RESolution]
:MODulation:OFFSet:CLOSe <freq> 381
[:SENSe]:EORFspectr:BANDwidth | BWIDth[:RESolution]
:MODulation:OFFSet:CLOSe? 381
[:SENSe]:EORFspectr:BANDwidth | BWIDth[:RESolution]
:MODulation:OFFSet:FAR <freq> 381
[:SENSe]:EORFspectr:BANDwidth | BWIDth[:RESolution]
:MODulation:OFFSet:FAR? 381

Commands

`[[:SENSe]:EORFspectr:BANDwidth | BWIDth[:RESolution]
:SWITching:CARRier <freq> 382`

`[[:SENSe]:EORFspectr:BANDwidth | BWIDth[:RESolution]
:SWITching:CARRier? 382`

`[[:SENSe]:EORFspectr:BANDwidth | BWIDth[:RESolution]
:SWITching:OFFSet:CLOSe <freq> 382`

`[[:SENSe]:EORFspectr:BANDwidth | BWIDth[:RESolution]
:SWITching:OFFSet:CLOSe? 382`

`[[:SENSe]:EORFspectr:BANDwidth | BWIDth[:RESolution]
:SWITching:OFFSet:FAR <freq> 382`

`[[:SENSe]:EORFspectr:BANDwidth | BWIDth[:RESolution]
:SWITching:OFFSet:FAR? 383`

`[[:SENSe]:EORFspectr:BFRequency <freq> 383`

`[[:SENSe]:EORFspectr:BFRequency? 383`

`[[:SENSe]:EORFspectr:LIST:MODulation:BANDwidth | BWIDth
<res bw>{,<res bw>} 384`

`[[:SENSe]:EORFspectr:LIST:MODulation:BANDwidth | BWIDth? 384`

`[[:SENSe]:EORFspectr:LIST:MODulation:LOFFset <level>{,<level>} 385`

`[[:SENSe]:EORFspectr:LIST:MODulation:LOFFset? 385`

`[[:SENSe]:EORFspectr:LIST:MODulation[:FREQuency]
<offset freq>{,<offset freq>} 384`

`[[:SENSe]:EORFspectr:LIST:MODulation[:FREQuency]? 384`

`[[:SENSe]:EORFspectr:LIST:SElect CUSTom | SHORt | STANdard 386`

`[[:SENSe]:EORFspectr:LIST:SElect? 386`

`[[:SENSe]:EORFspectr:LIST:SWITching:BANDwidth | BWIDth
<res bw>{,<res bw>} 386`

`[[:SENSe]:EORFspectr:LIST:SWITching:BANDwidth | BWIDth? 386`

`[[:SENSe]:EORFspectr:LIST:SWITching:LOFFset <level>{,<level>} 387`

`[[:SENSe]:EORFspectr:LIST:SWITching:LOFFset? 387`

`[[:SENSe]:EORFspectr:LIST:SWITching[:FREQuency]
<offset freq>{,<offset freq>} 387`

`[[:SENSe]:EORFspectr:LIST:SWITching[:FREQuency]? 387`

`[[:SENSe]:EORFspectr:MEASure MULTiple | SINGle 388`

`[[:SENSe]:EORFspectr:MEASure? 388`

`[[:SENSe]:EORFspectr:OFRequency <freq> 388`

Commands

[[:SENSe]:EORFspectr:OFRequency? 388

[[:SENSe]:EORFspectr:TRIGger:SOURce EXTernal[1] | EXTernal2 | FRAME | IMMEDIATE | RFBurst 389

[[:SENSe]:EORFspectr:TRIGger:SOURce? 389

[[:SENSe]:EORFspectr:TYPE MODulation | MSWitching | SWITching | FFModulation 389

[[:SENSe]:EORFspectr:TYPE:MODulation[:METHod] DISCcrete | SWEep 390

[[:SENSe]:EORFspectr:TYPE:MODulation[:METHod]? 390

[[:SENSe]:EORFspectr:TYPE? 389

[[:SENSe]:EPVTime:AVERage:COUNT <integer> 391

[[:SENSe]:EPVTime:AVERage:COUNT? 391

[[:SENSe]:EPVTime:AVERage:TCONtrol EXPonential | REPeat 391

[[:SENSe]:EPVTime:AVERage:TCONtrol? 391

[[:SENSe]:EPVTime:AVERage:TYPE LOG | MAXimum | MINimum | MXMinimum | RMS 392

[[:SENSe]:EPVTime:AVERage:TYPE? 392

[[:SENSe]:EPVTime:AVERage[:STATe] OFF | ON | 0 | 1 391

[[:SENSe]:EPVTime:AVERage[:STATe]? 391

[[:SENSe]:EPVTime:BANDwidth | BWIDth[:RESolution] <freq> 392

[[:SENSe]:EPVTime:BANDwidth | BWIDth[:RESolution]:TYPE FLATtop | GAUSSian 393

[[:SENSe]:EPVTime:BANDwidth | BWIDth[:RESolution]:TYPE? 393

[[:SENSe]:EPVTime:BANDwidth | BWIDth[:RESolution]? 392

[[:SENSe]:EPVTime:BSYNc:SOURce RFBurst | TSEQUence 393

[[:SENSe]:EPVTime:BSYNc:SOURce? 393

[[:SENSe]:EPVTime:LIMit:MASK OFF | ON | 0 | 1 393

[[:SENSe]:EPVTime:LIMit:MASK? 393

[[:SENSe]:EPVTime:MASK:LIST:LOWer:ABSolute <power>, <power>, <power>, <power>, <power> 394

[[:SENSe]:EPVTime:MASK:LIST:LOWer:ABSolute? 394

[[:SENSe]:EPVTime:MASK:LIST:LOWer:POINts? 394

[[:SENSe]:EPVTime:MASK:LIST:LOWer:RELative <rel_power>, <rel_power>, <rel_power>, <rel_power>, <rel_power> 395

[[:SENSe]:EPVTime:MASK:LIST:LOWer:RELative? 395

[[:SENSe]:EPVTime:MASK:LIST:LOWer:TIME <seconds>, <seconds>, <seconds>, <seconds>, <sec-

Commands

onds> 395

[[:SENSe]:EPVTime:MASK:LIST:LOWer:TIME? 395

[[:SENSe]:EPVTime:MASK:LIST:UPPer:ABSolute <power>, <power>, <power>, <power>, <power>
396

[[:SENSe]:EPVTime:MASK:LIST:UPPer:ABSolute? 396

[[:SENSe]:EPVTime:MASK:LIST:UPPer:POINts? 397

[[:SENSe]:EPVTime:MASK:LIST:UPPer:RELative <rel_power>, <rel_power>, <rel_power>,
<rel_power>, <rel_power> 397

[[:SENSe]:EPVTime:MASK:LIST:UPPer:RELative? 397

[[:SENSe]:EPVTime:MASK:LIST:UPPer:TIME <seconds>, <seconds>, <seconds>, <seconds>, <sec-
onds> 399

[[:SENSe]:EPVTime:MASK:LIST:UPPer:TIME? 399

[[:SENSe]:EPVTime:MASK:SELEct STANdard | CUSTom 396

[[:SENSe]:EPVTime:MASK:SELEct? 396

[[:SENSe]:EPVTime:PCLevel <integer> 399

[[:SENSe]:EPVTime:SWEep:TIME <integer> 400

[[:SENSe]:EPVTime:SWEep:TIME? 400

[[:SENSe]:EPVTime:TRIGger:SOURce EXTernal[1] | EXTernal2
| FRAMe | IF | IMMEDIATE | RFBurst 400

[[:SENSe]:EPVTime:TRIGger:SOURce? 400

[[:SENSe]:ETSPur:AVERage:COUNT <integer> 402

[[:SENSe]:ETSPur:AVERage:COUNT? 402

[[:SENSe]:ETSPur:AVERage:TCONtrol EXPonential | REPEat 402

[[:SENSe]:ETSPur:AVERage:TCONtrol? 402

[[:SENSe]:ETSPur:AVERage:TYPE LOG | MAXimum | RMS 403

[[:SENSe]:ETSPur:AVERage:TYPE? 403

[[:SENSe]:ETSPur:AVERage[:STATe] OFF | ON | 0 | 1 402

[[:SENSe]:ETSPur:AVERage[:STATe]? 402

[[:SENSe]:ETSPur:TYPE EXAMine | FULL 403

[[:SENSe]:ETSPur:TYPE? 403

[[:SENSe]:EVM:AVERage:COUNT <integer> 405

[[:SENSe]:EVM:AVERage:COUNT? 405

Commands

[:SENSe]:EVM:AVERAge:TCONtrol EXPonential | REPeat 405
[:SENSe]:EVM:AVERAge:TCONtrol? 405
[:SENSe]:EVM:AVERAge[:STATe] OFF | ON | 0 | 1 405
[:SENSe]:EVM:AVERAge[:STATe]? 405
[:SENSe]:EVM:BSYNc:SOURce RFAMplitude | SWORd | NONE 406
[:SENSe]:EVM:BSYNc:SOURce? 406
[:SENSe]:EVM:TRACe:PPSYmbol <integer> 406
[:SENSe]:EVM:TRACe:PPSYmbol? 406
[:SENSe]:EVM:TRIGger:SOURce EXTernal[1] | EXTernal2 | FRAMe | IF | IMMEDIATE | RFBurst 406
[:SENSe]:EVM:TRIGger:SOURce? 406
[:SENSe]:EVMQpsk:ADC:RANGe AUTO | APEak | APLOCK | M6 | P0 | P6 | P12 | P18 | P24 408
[:SENSe]:EVMQpsk:ADC:RANGe AUTO | APEak | APLOCK | NONE | P0 | P6 | P12 | P18 408
[:SENSe]:EVMQpsk:ADC:RANGe? 408
[:SENSe]:EVMQpsk:ALPHa <numeric> 409
[:SENSe]:EVMQpsk:ALPHa? 409
[:SENSe]:EVMQpsk:AVERAge:COUNt <integer> 409
[:SENSe]:EVMQpsk:AVERAge:COUNt? 409
[:SENSe]:EVMQpsk:AVERAge:TCONtrol EXPonential | REPeat 410
[:SENSe]:EVMQpsk:AVERAge:TCONtrol? 410
[:SENSe]:EVMQpsk:AVERAge[:STATe] OFF | ON | 0 | 1 410
[:SENSe]:EVMQpsk:AVERAge[:STATe]? 410
[:SENSe]:EVMQpsk:CONStln QPSK | RMC122 410
[:SENSe]:EVMQpsk:CONStln? 410
[:SENSe]:EVMQpsk:CRATe <freq> 411
[:SENSe]:EVMQpsk:CRATe? 411
[:SENSe]:EVMQpsk:RFCarrier MULTiple | SINGle 411
[:SENSe]:EVMQpsk:RFCarrier? 411
[:SENSe]:EVMQpsk:SPECTrum INVert | NORMal 412
[:SENSe]:EVMQpsk:SPECTrum? 412
[:SENSe]:EVMQpsk:SWEEp:POINts <integer> 412
[:SENSe]:EVMQpsk:SWEEp:POINts:OFFSet <number> 412

Commands

[[:SENSe]:EVMQpsk:SWEep:POINts:OFFSet? 412
[:SENSe]:EVMQpsk:SWEep:POINts? 412
[:SENSe]:EVMQpsk:TRIGger:SOURce EXTernal[1] | EXTernal2 | FRAME | IF | IMMEDIATE | RFBurst
413
[:SENSe]:EVMQpsk:TRIGger:SOURce? 413
[:SENSe]:FEED RF | AREFERENCE | IFALIGN 414
[:SENSe]:FEED RF | IQ | IONLY | QONLY | AREFERENCE | IFALIGN 414
[:SENSe]:FEED? 414
[:SENSe]:FREQuency:CENTer <freq> 415
[:SENSe]:FREQuency:CENTer:STEP:AUTO OFF | ON | 0 | 1 415
[:SENSe]:FREQuency:CENTer:STEP:AUTO? 415
[:SENSe]:FREQuency:CENTer:STEP[:INCRement] <freq> 415
[:SENSe]:FREQuency:CENTer:STEP[:INCRement]? 415
[:SENSe]:FREQuency:CENTer? 415
[:SENSe]:IM:AVERage:COUNt <number> 416
[:SENSe]:IM:AVERage:COUNt? 416
[:SENSe]:IM:AVERage:TCONtrol EXPONential | REPeat 417
[:SENSe]:IM:AVERage:TCONtrol? 417
[:SENSe]:IM:AVERage[:STATe] OFF | ON | 0 | 1 416
[:SENSe]:IM:AVERage[:STATe]? 416
[:SENSe]:IM:BANDwidth | BWIDth:INTegration <freq> 417
[:SENSe]:IM:BANDwidth | BWIDth:INTegration? 417
[:SENSe]:IM:BANDwidth | BWIDth[:RESolution] <freq> 417
[:SENSe]:IM:BANDwidth | BWIDth[:RESolution]:AUTO OFF | ON | 0 | 1 418
[:SENSe]:IM:BANDwidth | BWIDth[:RESolution]:AUTO? 418
[:SENSe]:IM:BANDwidth | BWIDth[:RESolution]? 417
[:SENSe]:IM:FILTer[:RRC]:ALPHa <numeric> 418
[:SENSe]:IM:FILTer[:RRC]:ALPHa? 418
[:SENSe]:IM:FILTer[:RRC][:STATe] OFF | ON | 0 | 1 418
[:SENSe]:IM:FILTer[:RRC][:STATe]? 418
[:SENSe]:IM:FREQuency:AUTO OFF | ON | 0 | 1 418

Commands

[:SENSe]:IM:FREQuency:AUTO? 418
[:SENSe]:IM:FREQuency:SPAN <freq> 420
[:SENSe]:IM:FREQuency:SPAN? 420
[:SENSe]:IM:FREQuency[:BASE]:DELTA <freq> 419
[:SENSe]:IM:FREQuency[:BASE]:DELTA? 419
[:SENSe]:IM:FREQuency[:BASE]:LOWer <freq> 419
[:SENSe]:IM:FREQuency[:BASE]:LOWer? 419
[:SENSe]:IM:FREQuency[:BASE]:UPPer <freq> 420
[:SENSe]:IM:FREQuency[:BASE]:UPPer? 420
[:SENSe]:IM:MODE AUTO | TWOTone | TXIM 420
[:SENSe]:IM:MODE? 420
[:SENSe]:IM:REFerence AUTO | AVERAge | LOWer | UPPer 421
[:SENSe]:IM:REFerence? 421
[:SENSe]:MCPower:AVERAge:COUNT <integer> 422
[:SENSe]:MCPower:AVERAge:COUNT? 422
[:SENSe]:MCPower:AVERAge:TCONtrol EXPonential | REPeat 422
[:SENSe]:MCPower:AVERAge:TCONtrol? 422
[:SENSe]:MCPower:AVERAge[:STATe] OFF | ON | 0 | 1 422
[:SENSe]:MCPower:AVERAge[:STATe]? 422
[:SENSe]:MCPower:FILTer[:RRC]:ALPHA <numeric> 423
[:SENSe]:MCPower:FILTer[:RRC]:ALPHA? 423
[:SENSe]:MCPower:FILTer[:RRC][:STATe] OFF | ON | 0 | 1 423
[:SENSe]:MCPower:FILTer[:RRC][:STATe]? 423
[:SENSe]:MCPower:FREQuency[:BASE]:DELTA <freq> 423
[:SENSe]:MCPower:FREQuency[:BASE]:DELTA? 423
[:SENSe]:MCPower:OFFSet:LIST:ABSolute <abs_power>,<abs_pwer> 424
[:SENSe]:MCPower:OFFSet:LIST:ABSolute? 424
[:SENSe]:MCPower:OFFSet:LIST:RCARrier <rel_power>,<rel_power> 424
[:SENSe]:MCPower:OFFSet:LIST:RCARrier? 424
[:SENSe]:MCPower:OFFSet:LIST:TEST ABSolute | AND | OR | RELative, ABSolute | AND | OR | RELative 425

Commands

[[:SENSe]:MCPower:OFFSet:LIST:TEST? 425
[:SENSe]:MCPower:OFFSet:SElect ALL | TFS | TOI 425
[:SENSe]:MCPower:OFFSet:SElect? 425
[:SENSe]:MCPower:REFerence AUTO | AVERage | LOWer | UPPer 426
[:SENSe]:MCPower:REFerence? 426
[:SENSe]:OBW:AVERage:COUNT <integer> 426
[:SENSe]:OBW:AVERage:COUNT? 426
[:SENSe]:OBW:AVERage:TCONtrol EXPonential | REPeat 427
[:SENSe]:OBW:AVERage:TCONtrol? 427
[:SENSe]:OBW:AVERage[::STATe] OFF | ON | 0 | 1 427
[:SENSe]:OBW:AVERage[::STATe]? 427
[:SENSe]:OBW:BANDwidth | BWIDth[::RESolution] <freq> 428
[:SENSe]:OBW:BANDwidth | BWIDth[::RESolution]? 428
[:SENSe]:OBW:FFT:WINDow[::TYPE]
BH4Tap | BLACKman | FLATtop | GAUSSian | HAMMING | HANNing | KB70 | KB90 | KB110 | UNI-
Form 428
[:SENSe]:OBW:FFT:WINDow[::TYPE]? 428
[:SENSe]:OBW:FREQuency:SPAN <freq> 429
[:SENSe]:OBW:FREQuency:SPAN? 429
[:SENSe]:OBW:PERCent <number> 429
[:SENSe]:OBW:PERCent? 429
[:SENSe]:OBW:TRIGger:SOURce EXTernal[1] | EXTernal2 | FRAME | IF | IMMEDIATE | LINE | RF-
Burst 430
[:SENSe]:OBW:TRIGger:SOURce EXTernal[1] | EXTernal2 | IF | IMMEDIATE | RFBurst 429
[:SENSe]:OBW:TRIGger:SOURce EXTernal[1] | EXTernal2 | IF | IMMEDIATE | RFBurst 429
[:SENSe]:OBW:TRIGger:SOURce? 429
[:SENSe]:OBW:TRIGger:SOURce? 430
[:SENSe]:OBW:TRIGger:SOURce? 430
[:SENSe]:ORFSpectrum:AVERage:COUNT <integer> 430
[:SENSe]:ORFSpectrum:AVERage:COUNT? 431
[:SENSe]:ORFSpectrum:AVERage:FAST[::STATe] OFF | ON | 0 | 1 431
[:SENSe]:ORFSpectrum:AVERage:FAST[::STATe]? 431

Commands

[[:SENSe]:ORFSpectrum:AVERage:MODulation:TYPE LOG | RMS 431
[:SENSe]:ORFSpectrum:AVERage:MODulation:TYPE? 431
[:SENSe]:ORFSpectrum:AVERage:SWITching:TYPE? 432
[:SENSe]:ORFSpectrum:AVERage[:STATe] OFF | ON | 0 | 1 432
[:SENSe]:ORFSpectrum:AVERage[:STATe]? 432
[:SENSe]:ORFSpectrum:BANDwidth | BWIDth[:RESolution]
:MODulation:CARRier <freq> 432
[:SENSe]:ORFSpectrum:BANDwidth | BWIDth[:RESolution]
:MODulation:CARRier? 432
[:SENSe]:ORFSpectrum:BANDwidth | BWIDth[:RESolution]
:MODulation:OFFSet:CLOSe <freq> 433
[:SENSe]:ORFSpectrum:BANDwidth | BWIDth[:RESolution]
:MODulation:OFFSet:CLOSe? 433
[:SENSe]:ORFSpectrum:BANDwidth | BWIDth[:RESolution]
:MODulation:OFFSet:FAR <freq> 433
[:SENSe]:ORFSpectrum:BANDwidth | BWIDth[:RESolution]
:MODulation:OFFSet:FAR? 433
[:SENSe]:ORFSpectrum:BANDwidth | BWIDth[:RESolution]
:SWITching:CARRier <freq> 433
[:SENSe]:ORFSpectrum:BANDwidth | BWIDth[:RESolution]
:SWITching:CARRier? 433
[:SENSe]:ORFSpectrum:BANDwidth | BWIDth[:RESolution]
:SWITching:OFFSet:CLOSe <freq> 434
[:SENSe]:ORFSpectrum:BANDwidth | BWIDth[:RESolution]
:SWITching:OFFSet:CLOSe? 434
[:SENSe]:ORFSpectrum:BANDwidth | BWIDth[:RESolution]
:SWITching:OFFSet:FAR <freq> 434
[:SENSe]:ORFSpectrum:BANDwidth | BWIDth[:RESolution]
:SWITching:OFFSet:FAR? 434
[:SENSe]:ORFSpectrum:BFRequency <freq> 435
[:SENSe]:ORFSpectrum:BFRequency? 435
[:SENSe]:ORFSpectrum:DETEctor:SWITching:FAST[:STATe]OFF | ON | 0 | 1 383
[:SENSe]:ORFSpectrum:DETEctor:SWITching? 383
[:SENSe]:ORFSpectrum:LIST:MODulation:BANDwidth | BWIDth
<res bw>{,<res bw>} 435
[:SENSe]:ORFSpectrum:LIST:MODulation:BANDwidth | BWIDth? 435

Commands

[[:SENSe]:ORFSpectrum:LIST:MODulation:LOFFset <level>{,<level>} 436

[[:SENSe]:ORFSpectrum:LIST:MODulation:LOFFset? 436

[[:SENSe]:ORFSpectrum:LIST:MODulation[:FREQuency]
<offset freq>{,<offset freq>} 436

[[:SENSe]:ORFSpectrum:LIST:MODulation[:FREQuency]? 436

[[:SENSe]:ORFSpectrum:LIST:SELEct CUSTom | SHORt | STANdard 437

[[:SENSe]:ORFSpectrum:LIST:SELEct? 437

[[:SENSe]:ORFSpectrum:LIST:SWITching:BANDwidth | BWIDth <res_bw>{,<res_bw>} 438

[[:SENSe]:ORFSpectrum:LIST:SWITching:BANDwidth | BWIDth? 438

[[:SENSe]:ORFSpectrum:LIST:SWITching:LOFFset <level>{,<level>} 439

[[:SENSe]:ORFSpectrum:LIST:SWITching:LOFFset? 439

[[:SENSe]:ORFSpectrum:LIST:SWITching[:FREQuency] <offset_freq>{,<offset_freq>} 438

[[:SENSe]:ORFSpectrum:LIST:SWITching[:FREQuency]? 438

[[:SENSe]:ORFSpectrum:MEASure MULTiple | SINGle 439

[[:SENSe]:ORFSpectrum:MEASure? 439

[[:SENSe]:ORFSpectrum:OFRequency <freq> 440

[[:SENSe]:ORFSpectrum:OFRequency? 440

[[:SENSe]:ORFSpectrum:TRIGger:SOURce EXTernal[1] | EXTernal2 | FRAMe | IMMEDIATE | RFBurst
440

[[:SENSe]:ORFSpectrum:TRIGger:SOURce? 440

[[:SENSe]:ORFSpectrum:TYPE MODulation | MSWitching | SWITching | FFModulation 441

[[:SENSe]:ORFSpectrum:TYPE:MODulation[:METHod] DISCrete | SWEep 441

[[:SENSe]:ORFSpectrum:TYPE:MODulation[:METHod]? 441

[[:SENSe]:ORFSpectrum:TYPE? 441

[[:SENSe]:PCONtrol:BANDwidth | BWIDth[:RESolution] <freq> 442

[[:SENSe]:PCONtrol:BANDwidth | BWIDth[:RESolution]:TYPE FLATtop | GAUSSian 442

[[:SENSe]:PCONtrol:BANDwidth | BWIDth[:RESolution]:TYPE? 442

[[:SENSe]:PCONtrol:BANDwidth | BWIDth[:RESolution]? 442

[[:SENSe]:PCONtrol:CAPture:TIME <float> 442

[[:SENSe]:PCONtrol:CAPture:TIME? 442

[[:SENSe]:PCONtrol:CRATe <float> 443

[[:SENSe]:PCONtrol:CRATe? 443

Commands

[[:SENSe]:PCONtrol:FILTer[:RRC]:ALPHa <float> 443
[:SENSe]:PCONtrol:FILTer[:RRC]:ALPHa? 443
[:SENSe]:PCONtrol:FILTer[:RRC][:STATe] OFF | ON | 0 | 1 443
[:SENSe]:PCONtrol:FILTer[:RRC][:STATe]? 443
[:SENSe]:PCONtrol:METHod WAVeform | CPOWer 443
[:SENSe]:PCONtrol:METHod? 443
[:SENSe]:PCONtrol:PRACH:SIGNature <integer> 444
[:SENSe]:PCONtrol:PRACH:SIGNature:AUTO OFF | ON | 0 | 1 444
[:SENSe]:PCONtrol:PRACH:SIGNature:AUTO? 444
[:SENSe]:PCONtrol:PRACH:SIGNature? 444
[:SENSe]:PCONtrol:SLOT:FORMat SF0 | SF1 | SF2 | SF3 | SF4 | SF5 444
[:SENSe]:PCONtrol:SLOT:FORMat? 444
[:SENSe]:PCONtrol:SYNC:SCRamble <integer> 445
[:SENSe]:PCONtrol:SYNC:SCRamble? 445
[:SENSe]:PCONtrol:TRIGer:SOURce EXTernal[1] | EXTernal2 | FRAME | IF | IMMEDIATE | RF-
Burst | LINE 445
[:SENSe]:PCONtrol:TRIGer:SOURce? 445
[:SENSe]:PCONtrol:TYPE SLOT | PRACH 446
[:SENSe]:PCONtrol:TYPE? 446
[:SENSe]:PFERror:AVERage:COUNt <integer> 447
[:SENSe]:PFERror:AVERage:COUNt? 447
[:SENSe]:PFERror:AVERage:TCONtrol EXPonential | REPeat 447
[:SENSe]:PFERror:AVERage:TCONtrol? 447
[:SENSe]:PFERror:AVERage:TYPE MEAN | MAXimum 448
[:SENSe]:PFERror:AVERage:TYPE? 448
[:SENSe]:PFERror:AVERage[:STATe] OFF | ON | 0 | 1 447
[:SENSe]:PFERror:AVERage[:STATe]? 447
[:SENSe]:PFERror:BSYNc:SOURce EXTernal[1] | EXTernal2 | NONE | RFBurst | TSEquence 448
[:SENSe]:PFERror:BSYNc:SOURce? 448
[:SENSe]:PFERror:IQOFfset[:STATe] OFF | ON | 0 | 1 448
[:SENSe]:PFERror:IQOFfset[:STATe]? 448

Commands

[[:SENSE]:PFERror:TRACe[:STATe] OFF | ON | 0 | 1 449

[[:SENSE]:PFERror:TRACe[:STATe]? 449

[[:SENSE]:PFERror:TRIGger:SOURce EXTernal[1] | EXTernal2 | FRAME | IF | IMMEDIATE | RFBurst 449

[[:SENSE]:PFERror:TRIGger:SOURce? 449

[[:SENSE]:POWER:IQ:RANGE[:UPPer] <power> [DBM] | DBMV | W 346

[[:SENSE]:POWER:IQ:RANGE[:UPPer]<Float 64>{DBM} | DBMV | W 450

[[:SENSE]:POWER:IQ:RANGE[:UPPer]? 346

[[:SENSE]:POWER:IQ:RANGE[:UPPer]? 450

[[:SENSE]:POWER[:RF]:ATTenuation <rel_power> 451

[[:SENSE]:POWER[:RF]:ATTenuation? 451

[[:SENSE]:POWER[:RF]:GAIN:ATTenuation <rel_power> 451

[[:SENSE]:POWER[:RF]:GAIN:ATTenuation? 451

[[:SENSE]:POWER[:RF]:GAIN[:STATe] OFF | ON | 0 | 1 451

[[:SENSE]:POWER[:RF]:GAIN[:STATe]? 451

[[:SENSE]:POWER[:RF]:RANGE:AUTO OFF | ON | 0 | 1 452

[[:SENSE]:POWER[:RF]:RANGE:AUTO? 452

[[:SENSE]:POWER[:RF]:RANGE[:UPPer] <power> 452

[[:SENSE]:POWER[:RF]:RANGE[:UPPer]? 452

[[:SENSE]:PSTATistic:BANDwidth | BWIDth <freq> 454

[[:SENSE]:PSTATistic:BANDwidth | BWIDth? 454

[[:SENSE]:PSTATistic:COUNts <integer> 454

[[:SENSE]:PSTATistic:COUNts? 454

[[:SENSE]:PSTATistic:SWEEP:TIME <time> 454

[[:SENSE]:PSTATistic:SWEEP:TIME? 455

[[:SENSE]:PSTATistic:TRIGger:SOURce EXTernal[1] | EXTernal2 | FRAME | IF | IMMEDIATE | RFBurst 455

[[:SENSE]:PSTATistic:TRIGger:SOURce? 455

[[:SENSE]:PVTime:AVERage:COUNt <integer> 456

[[:SENSE]:PVTime:AVERage:COUNt <integer> 456

[[:SENSE]:PVTime:AVERage:COUNt? 456

[[:SENSE]:PVTime:AVERage:COUNt? 456

Commands

[[:SENSe]:PVTime:AVERAge:TCONtrol EXPonential | REPeat 457
[:SENSe]:PVTime:AVERAge:TCONtrol? 457
[:SENSe]:PVTime:AVERAge:TYPE LOG | MAXimum | MINimum | MXMinimum | RMS 457
[:SENSe]:PVTime:AVERAge:TYPE LOG | MAXimum | MINimum | MXMinimum | RMS | SCALar 457
[:SENSe]:PVTime:AVERAge:TYPE RMS | MAXimum | MINimum 457
[:SENSe]:PVTime:AVERAge:TYPE? 457
[:SENSe]:PVTime:AVERAge[:STATe] OFF | ON | 0 | 1 456
[:SENSe]:PVTime:AVERAge[:STATe]? 456
[:SENSe]:PVTime:BANDwidth | BWIDth[:RESolution] <freq> 458
[:SENSe]:PVTime:BANDwidth | BWIDth[:RESolution]:TYPE FLATtop | GAUSSian 458
[:SENSe]:PVTime:BANDwidth | BWIDth[:RESolution]:TYPE? 458
[:SENSe]:PVTime:BANDwidth | BWIDth[:RESolution]? 458
[:SENSe]:PVTime:BSYNc:SOURce RFBurst | TSEQUence 459
[:SENSe]:PVTime:BSYNc:SOURce? 459
[:SENSe]:PVTime:BURSt:SLOPe <number> 460
[:SENSe]:PVTime:BURSt:SLOPe:INTegration:TIME <number> 460
[:SENSe]:PVTime:BURSt:SLOPe:INTegration:TIME? 460
[:SENSe]:PVTime:BURSt:SLOPe? 460
[:SENSe]:PVTime:BURSt:STHReshold <rel_power> 459
[:SENSe]:PVTime:BURSt:STHReshold? 459
[:SENSe]:PVTime:CRATe <float> 460
[:SENSe]:PVTime:CRATe? 460
[:SENSe]:PVTime:FILTer[:RRC]:ALPHa <float> 461
[:SENSe]:PVTime:FILTer[:RRC]:ALPHa? 461
[:SENSe]:PVTime:FILTer[:RRC][:STATe] 0 | 1 | OFF | ON 461
[:SENSe]:PVTime:FILTer[:RRC][:STATe]? 461
[:SENSe]:PVTime:LIMit:MASK OFF | ON | 0 | 1 461
[:SENSe]:PVTime:LIMit:MASK? 461
[:SENSe]:PVTime:MASK:ASLot:LOWer:RELative <rel_power> 462
[:SENSe]:PVTime:MASK:ASLot:LOWer:RELative? 462
[:SENSe]:PVTime:MASK:ASLot:LOWer:TEST RELative | NONE 462

Commands

[:SENSe]:PVTime:MASK:ASLot:LOWer:TEST? 462

[:SENSe]:PVTime:MASK:ASLot:SWEep:TIME <time> 462

[:SENSe]:PVTime:MASK:ASLot:SWEep:TIME? 462

[:SENSe]:PVTime:MASK:ASLot:UPPer:RELative <rel_power> 463

[:SENSe]:PVTime:MASK:ASLot:UPPer:RELative? 463

[:SENSe]:PVTime:MASK:ASLot:UPPer:TEST RELative | NONE 463

[:SENSe]:PVTime:MASK:ASLot:UPPer:TEST? 463

[:SENSe]:PVTime:MASK:LIST:LOWer:ABSolute <power>, <power>, <power>, <power>, <power>
464

[:SENSe]:PVTime:MASK:LIST:LOWer:ABSolute? 464

[:SENSe]:PVTime:MASK:LIST:LOWer:POINts? 464

[:SENSe]:PVTime:MASK:LIST:LOWer:RELative <rel_power>, <rel_power>, <rel_power>,
<rel_power>, <rel_power> 465

[:SENSe]:PVTime:MASK:LIST:LOWer:RELative? 465

[:SENSe]:PVTime:MASK:LIST:LOWer:TEST RELative | NONE, ,RELative | NONE, RELa-
tive | NONE, RELative | NONE, RELative | NONE 465

[:SENSe]:PVTime:MASK:LIST:LOWer:TEST? 465

[:SENSe]:PVTime:MASK:LIST:LOWer:TIME <seconds>{, <seconds>} 466

[:SENSe]:PVTime:MASK:LIST:LOWer:TIME? 466

[:SENSe]:PVTime:MASK:LIST:PREFerence A | B | C | D | E 466

[:SENSe]:PVTime:MASK:LIST:PREFerence? 466

[:SENSe]:PVTime:MASK:LIST:SWEep:TIME <seconds>{, <seconds>} 467

[:SENSe]:PVTime:MASK:LIST:SWEep:TIME <time>, <time>, <time>, <time>, <time> 468

[:SENSe]:PVTime:MASK:LIST:SWEep:TIME? 467

[:SENSe]:PVTime:MASK:LIST:SWEep:TIME? 468

[:SENSe]:PVTime:MASK:LIST:TIME <seconds>{, <seconds>} 467

[:SENSe]:PVTime:MASK:LIST:TIME <time>, <time>, <time>, <time>, <time> 468

[:SENSe]:PVTime:MASK:LIST:TIME? 467

[:SENSe]:PVTime:MASK:LIST:TIME? 468

[:SENSe]:PVTime:MASK:LIST:UPPer:ABSolute <power>, <power>, <power>, <power>, <power>
468

[:SENSe]:PVTime:MASK:LIST:UPPer:ABSolute? 469

Commands

[[:SENSe]:PVTime:MASK:LIST:UPPer:POINts? 469

[[:SENSe]:PVTime:MASK:LIST:UPPer:RELative <rel_power>, <rel_power>, <rel_power>, <rel_power>, <rel_power> 470

[[:SENSe]:PVTime:MASK:LIST:UPPer:RELative? 470

[[:SENSe]:PVTime:MASK:LIST:UPPer:TEST RELative | NONE, RELative | NONE, RELative | NONE, RELative | NONE, RELative | NONE, RELative | NONE 471

[[:SENSe]:PVTime:MASK:LIST:UPPer:TEST? 471

[[:SENSe]:PVTime:MASK:LIST:UPPer:TIME <seconds>, <seconds>, <seconds>, <seconds>, <seconds> 472

[[:SENSe]:PVTime:MASK:LIST:UPPer:TIME? 472

[[:SENSe]:PVTime:MASK:PREFERENCE A | B | C | D | E 467

[[:SENSe]:PVTime:MASK:PREFERENCE? 467

[[:SENSe]:PVTime:MASK:REFERENCE TRIGger | RISE | CENTer 472

[[:SENSe]:PVTime:MASK:REFERENCE? 472

[[:SENSe]:PVTime:MASK:REFERENCE[:OFFSet]:TIME <time> 473

[[:SENSe]:PVTime:MASK:REFERENCE[:OFFSet]:TIME? 473

[[:SENSe]:PVTime:MASK:SElect STANDard | CUSTom 473

[[:SENSe]:PVTime:MASK:SElect? 473

[[:SENSe]:PVTime:PCLevel <integer> 474

[[:SENSe]:PVTime:PCLevel? 474

[[:SENSe]:PVTime:SLOT[:TYPE] IDLE | ACTive 474

[[:SENSe]:PVTime:SLOT[:TYPE]? 474

[[:SENSe]:PVTime:SWEEP:TIME <integer> 475

[[:SENSe]:PVTime:SWEEP:TIME? 475

[[:SENSe]:PVTime:TRIGger:SOURce EXTernal[1] | EXTernal2 | FRAME | LINE | IF | IMMEDIATE | RFBurst 475

[[:SENSe]:PVTime:TRIGger:SOURce? 475

[[:SENSe]:RADio:CARRier:HOP OFF | ON | 0 | 1 477

[[:SENSe]:RADio:CARRier:HOP? 477

[[:SENSe]:RADio:CARRier:NUMBer SINGLE | MULTiple 477

[[:SENSe]:RADio:CARRier:NUMBer? 477

[[:SENSe]:RADio:CARRier[:TYPE] BURSt | CONTinuous 477

Commands

`[:SENSe]:RADio:CARRier[:TYPE]? 477`
`[:SENSe]:RADio:DEVice BS | MS 478`
`[:SENSe]:RADio:DEVice BTS | MS 478`
`[:SENSe]:RADio:DEVice INBound | OUTBound 479`
`[:SENSe]:RADio:DEVice:BASE[:TYPE] NORMal | MICRo | PICO 479`
`[:SENSe]:RADio:DEVice:BASE[:TYPE]? 479`
`[:SENSe]:RADio:DEVice? 478`
`[:SENSe]:RADio:DEVice? 478`
`[:SENSe]:RADio:DEVice? 479`
`[:SENSe]:RADio:FORMat M16QAM | M64QAM | DJSMR 479`
`[:SENSe]:RADio:FORMat? 479`
`[:SENSe]:RADio:STANdard:BAND IS95A | JSTD8 | IS97D 481`
`[:SENSe]:RADio:STANdard:BAND
PGSM | EGSM | RGSM | DCS1800 | PCS1900 | GSM450 | GSM480 | GSM700 | GSM850 480`
`[:SENSe]:RADio:STANdard:BAND:CLASs BC0 | BC1 | BC3 | BC4 481`
`[:SENSe]:RADio:STANdard:BAND:CLASs? 481`
`[:SENSe]:RADio:STANdard:BAND? 480`
`[:SENSe]:RADio:STANdard:BAND? 481`
`[:SENSe]:RADio:TRATe FULL | HALF 482`
`[:SENSe]:RADio:TRATe? 482`
`[:SENSe]:RHO:ACODE AUTO | PREDeFined 482`
`[:SENSe]:RHO:ACODE? 482`
`[:SENSe]:RHO:ADC:RANGe AUTO | APEak | APLock | NONE | M6 | P0 | P6 | P12 | P18 | P24 482`
`[:SENSe]:RHO:ADC:RANGe? 482`
`[:SENSe]:RHO:ALPHa <numeric> 483`
`[:SENSe]:RHO:ALPHa? 483`
`[:SENSe]:RHO:AVERAge:COUNT <integer> 484`
`[:SENSe]:RHO:AVERAge:COUNT? 484`
`[:SENSe]:RHO:AVERAge:TCONtrol EXPonential | REPeat 484`
`[:SENSe]:RHO:AVERAge:TCONtrol? 484`
`[:SENSe]:RHO:AVERAge[:STATe] OFF | ON | 0 | 1 484`

Commands

[[:SENSe]:RHO:AVERage[:STATe]? 484

[[:SENSe]:RHO:CPICH[:STATe] OFF | ON | 0 | 1 485

[[:SENSe]:RHO:CPICH[:STATe]? 485

[[:SENSe]:RHO:CRATe <freq> 485

[[:SENSe]:RHO:CRATe? 485

[[:SENSe]:RHO:MCEStimator OFF | ON | 0 | 1 485

[[:SENSe]:RHO:MCEStimator? 485

[[:SENSe]:RHO:PNOFfset <integer> 486

[[:SENSe]:RHO:PNOFfset? 486

[[:SENSe]:RHO:PRACH:SIGNature <integer> 486

[[:SENSe]:RHO:PRACH:SIGNature:AUTO OFF | ON | 0 | 1 486

[[:SENSe]:RHO:PRACH:SIGNature:AUTO? 486

[[:SENSe]:RHO:PRACH:SIGNature? 486

[[:SENSe]:RHO:PREamble:LENGth <integer> 487

[[:SENSe]:RHO:PREamble:LENGth:AUTO OFF | ON | 0 | 1 487

[[:SENSe]:RHO:PREamble:LENGth:AUTO? 487

[[:SENSe]:RHO:PREamble:LENGth? 487

[[:SENSe]:RHO:PREamble:STATe OFF | ON | 0 | 1 487

[[:SENSe]:RHO:PREamble:STATe? 487

[[:SENSe]:RHO:SBOundary? 488

[[:SENSe]:RHO:SBOundary[:BTS] AU-
TO | MAX | TM1D16 | TM1D32 | TM1D64 | TM2 | TM3D16 | TM3D32 488

[[:SENSe]:RHO:SFORmat:MS SF0 | SF1 | SF2 | SF3 | SF4 | SF5 489

[[:SENSe]:RHO:SFORmat:MS? 489

[[:SENSe]:RHO:SPECTrum INVert | NORMAl 489

[[:SENSe]:RHO:SPECTrum? 489

[[:SENSe]:RHO:SWEep:TIME <time> 489

[[:SENSe]:RHO:SWEep:TIME:SCH INCLude | EXCLude 490

[[:SENSe]:RHO:SWEep:TIME:SCH? 490

[[:SENSe]:RHO:SWEep:TIME? 489

[[:SENSe]:RHO:SYNC:LCMask <integer> 491

Commands

[:SENSe]:RHO:SYNC:LCMask? 491

[:SENSe]:RHO:SYNC:MS DPCCh | PMESage 491

[:SENSe]:RHO:SYNC:MS? 491

[:SENSe]:RHO:SYNC:SCRamble:MS <integer> 492

[:SENSe]:RHO:SYNC:SCRamble:MS? 492

[:SENSe]:RHO:SYNC:SCRamble[:BTS] <integer> 491

[:SENSe]:RHO:SYNC:SCRamble[:BTS]:OFFSet <integer> 491

[:SENSe]:RHO:SYNC:SCRamble[:BTS]:OFFSet? 492

[:SENSe]:RHO:SYNC:SCRamble[:BTS]:TYPE LEFT | RIGHT | STANdard 492

[:SENSe]:RHO:SYNC:SCRamble[:BTS]:TYPE? 492

[:SENSe]:RHO:SYNC:SCRamble[:BTS]? 491

[:SENSe]:RHO:SYNC:SYMBOL:SPRead <integer> 492

[:SENSe]:RHO:SYNC:SYMBOL:SPRead? 492

[:SENSe]:RHO:SYNC:SYMBOL:SRATe <integer> 493

[:SENSe]:RHO:SYNC:SYMBOL:SRATe? 493

[:SENSe]:RHO:SYNC[:BTS] CPICH | SCH | SYMBOL | STTD | A2CPich 490

[:SENSe]:RHO:SYNC[:BTS]? 490

[:SENSe]:RHO:TRIGger:SOURce EXTERNAL[1] | External2 | FRAME | IF | IMMEDIATE | RFBurst 493

[:SENSe]:RHO:TRIGger:SOURce? 493

[:SENSe]:ROSCillator:EXTERNAL:FREQUENCY <frequency> 495

[:SENSe]:ROSCillator:EXTERNAL:FREQUENCY? 495

[:SENSe]:ROSCillator:OUTPUT? 495

[:SENSe]:ROSCillator:OUTPUT[:STATe] OFF | ON | 0 | 1 495

[:SENSe]:ROSCillator:SOURce INTERNAL | EXTERNAL 495

[:SENSe]:ROSCillator:SOURce? 495

[:SENSe]:SEMask:AVERage:COUNT <integer> 496

[:SENSe]:SEMask:AVERage:COUNT? 496

[:SENSe]:SEMask:AVERage:TCONTROL EXPONENTIAL | REPEAT 497

[:SENSe]:SEMask:AVERage:TCONTROL? 497

[:SENSe]:SEMask:AVERage[:STATe] OFF | ON | 0 | 1 496

[:SENSe]:SEMask:AVERage[:STATe]? 496

Commands

[[:SENSe]:SEMAsk:BANDwidth[n] | BWIDth[n]:INTEgration <freq> 497
[:SENSe]:SEMAsk:BANDwidth[n] | BWIDth[n]:INTEgration? 497
[:SENSe]:SEMAsk:BANDwidth[n] | BWIDth[n]:RESolution <freq> 498
[:SENSe]:SEMAsk:BANDwidth[n] | BWIDth[n]:RESolution:AUTO OFF | ON | 0 | 1 498
[:SENSe]:SEMAsk:BANDwidth[n] | BWIDth[n]:RESolution:AUTO? 498
[:SENSe]:SEMAsk:BANDwidth[n] | BWIDth[n]:RESolution? 498
[:SENSe]:SEMAsk:BANDwidth | BWIDth:INTEgration[m] <freq> 497
[:SENSe]:SEMAsk:BANDwidth | BWIDth:INTEgration[m]? 497
[:SENSe]:SEMAsk:BANDwidth | BWIDth:RESolution[m] <freq> 498
[:SENSe]:SEMAsk:BANDwidth | BWIDth:RESolution[m]:AUTO OFF | ON | 0 | 1 498
[:SENSe]:SEMAsk:BANDwidth | BWIDth:RESolution[m]:AUTO? 498
[:SENSe]:SEMAsk:BANDwidth | BWIDth:RESolution[m]? 498
[:SENSe]:SEMAsk:DETEctor[:FUNCTion] AAVerage | POSitive 499
[:SENSe]:SEMAsk:DETEctor[:FUNCTion]? 499
[:SENSe]:SEMAsk:FREQuency:STEP[m] <freq> 500
[:SENSe]:SEMAsk:FREQuency:STEP[m]:AUTO OFF | ON | 0 | 1 500
[:SENSe]:SEMAsk:FREQuency:STEP[m]:AUTO? 500
[:SENSe]:SEMAsk:FREQuency:STEP[m]? 500
[:SENSe]:SEMAsk:FREQuency[n]:SPAN[m] <freq> 499
[:SENSe]:SEMAsk:FREQuency[n]:SPAN[m]? 499
[:SENSe]:SEMAsk:FREQuency[n]:STEP <freq> 500
[:SENSe]:SEMAsk:FREQuency[n]:STEP:AUTO OFF | ON | 0 | 1 500
[:SENSe]:SEMAsk:FREQuency[n]:STEP:AUTO? 500
[:SENSe]:SEMAsk:FREQuency[n]:STEP? 500
[:SENSe]:SEMAsk:OFFSet:LIST[m]:BANDwidth | BWIDth
<res_bw>,<res_bw>,<res_bw>,<res_bw>,<res_bw> 501
[:SENSe]:SEMAsk:OFFSet:LIST[m]:BANDwidth | BWIDth:AUTO
OFF | ON | 0 | 1,OFF | ON | 0 | 1,OFF | ON | 0 | 1,OFF | ON | 0 | 1,OFF | ON | 0 | 1 502
[:SENSe]:SEMAsk:OFFSet:LIST[m]:BANDwidth | BWIDth:AUTO? 502
[:SENSe]:SEMAsk:OFFSet:LIST[m]:BANDwidth | BWIDth:IMULti
<integer>,<integer>,<integer>,<integer>,<integer> 503
[:SENSe]:SEMAsk:OFFSet:LIST[m]:BANDwidth | BWIDth:IMULti? 503

Commands

[[:SENSE]:SEMAsk:OFFSet:LIST[m]:BANDwidth | BWIDth? 501

[[:SENSE]:SEMAsk:OFFSet:LIST[m]:FREQuency:STARt
<f_offset>,<f_offset>,<f_offset>,<f_offset>,<f_offset> 504

[[:SENSE]:SEMAsk:OFFSet:LIST[m]:FREQuency:STARt? 504

[[:SENSE]:SEMAsk:OFFSet:LIST[m]:FREQuency:STEP
<f_offset>,<f_offset>,<f_offset>,<f_offset>,<f_offset> 505

[[:SENSE]:SEMAsk:OFFSet:LIST[m]:FREQuency:STEP:AUTO
OFF | ON | 0 | 1,OFF | ON | 0 | 1,OFF | ON | 0 | 1,OFF | ON | 0 | 1,OFF | ON | 0 | 1 505

[[:SENSE]:SEMAsk:OFFSet:LIST[m]:FREQuency:STEP:AUTO? 505

[[:SENSE]:SEMAsk:OFFSet:LIST[m]:FREQuency:STEP? 505

[[:SENSE]:SEMAsk:OFFSet:LIST[m]:FREQuency:STOP
<f_offset>,<f_offset>,<f_offset>,<f_offset>,<f_offset> 506

[[:SENSE]:SEMAsk:OFFSet:LIST[m]:FREQuency:STOP? 506

[[:SENSE]:SEMAsk:OFFSet:LIST[m]:RATTenuation
<rel_power>,<rel_power>,<rel_power>,<rel_power>,<rel_power> 507

[[:SENSE]:SEMAsk:OFFSet:LIST[m]:RATTenuation? 507

[[:SENSE]:SEMAsk:OFFSet:LIST[m]:SIDE BOTH | NEGative | POSitive,
BOTH | NEGative | POSitive,BOTH | NEGative | POSitive, BOTH | NEGative | POSi-
tive,BOTH | NEGative | POSitive 508

[[:SENSE]:SEMAsk:OFFSet:LIST[m]:SIDE? 508

[[:SENSE]:SEMAsk:OFFSet:LIST[m]:STARt:ABSolute
<abs_power>,<abs_power>,<abs_power>,<abs_power>,<abs_power> 509

[[:SENSE]:SEMAsk:OFFSet:LIST[M]:STARt:ABSolute? 509

[[:SENSE]:SEMAsk:OFFSet:LIST[m]:STARt:RCARrier
<rel_power>,<rel_power>,<rel_power>,<rel_power>,<rel_power> 510

[[:SENSE]:SEMAsk:OFFSet:LIST[m]:STARt:RCARrier? 510

[[:SENSE]:SEMAsk:OFFSet:LIST[m]:STATe
OFF | ON | 0 | 1,OFF | ON | 0 | 1,OFF | ON | 0 | 1,OFF | ON | 0 | 1,OFF | ON | 0 | 1 511

[[:SENSE]:SEMAsk:OFFSet:LIST[m]:STATe? 511

[[:SENSE]:SEMAsk:OFFSet:LIST[m]:STOP:ABSolute
<abs_power>,<abs_power>,<abs_power>,<abs_power>,<abs_power> 512

[[:SENSE]:SEMAsk:OFFSet:LIST[m]:STOP:ABSolute:COUple
OFF | ON | 0 | 1,OFF | ON | 0 | 1,OFF | ON | 0 | 1,OFF | ON | 0 | 1,OFF | ON | 0 | 1 513

[[:SENSE]:SEMAsk:OFFSet:LIST[m]:STOP:ABSolute:COUple? 513

[[:SENSE]:SEMAsk:OFFSet:LIST[m]:STOP:ABSolute? 512

Commands

[[:SENSe]:SEMAsk:OFFSet:LIST[m]:STOP:RCARrier
<rel_power>,<rel_power>,<rel_power>,<rel_power>,<rel_power> 514

[[:SENSe]:SEMAsk:OFFSet:LIST[m]:STOP:RCARrier:COUPle
OFF | ON | 0 | 1,OFF | ON | 0 | 1,OFF | ON | 0 | 1,OFF | ON | 0 | 1,OFF | ON | 0 | 1 515

[[:SENSe]:SEMAsk:OFFSet:LIST[m]:STOP:RCARrier:COUPle? 515

[[:SENSe]:SEMAsk:OFFSet:LIST[m]:STOP:RCARrier? 514

[[:SENSe]:SEMAsk:OFFSet:LIST[m]:TEST
ABSolute | AND | OR | RELative,ABSolute | AND | OR | RELative,
ABSolute | AND | OR | RELative,ABSolute | AND | OR | RELative,
ABSolute | AND | OR | RELative 516

[[:SENSe]:SEMAsk:OFFSet:LIST[m]:TEST? 516

[[:SENSe]:SEMAsk:OFFSet[n]:LIST:BANDwidth | BWIDth
<res_bw>,<res_bw>,<res_bw>,<res_bw>,<res_bw> 501

[[:SENSe]:SEMAsk:OFFSet[n]:LIST:BANDwidth | BWIDth:AUTO
OFF | ON | 0 | 1,OFF | ON | 0 | 1,OFF | ON | 0 | 1,OFF | ON | 0 | 1,OFF | ON | 0 | 1 502

[[:SENSe]:SEMAsk:OFFSet[n]:LIST:BANDwidth | BWIDth:AUTO? 502

[[:SENSe]:SEMAsk:OFFSet[n]:LIST:BANDwidth | BWIDth:IMULti
<integer>,<integer>,<integer>,<integer>,<integer> 503

[[:SENSe]:SEMAsk:OFFSet[n]:LIST:BANDwidth | BWIDth:IMULti? 503

[[:SENSe]:SEMAsk:OFFSet[n]:LIST:BANDwidth | BWIDth? 501

[[:SENSe]:SEMAsk:OFFSet[n]:LIST:FREQuency:START
<f_offset>,<f_offset>,<f_offset>,<f_offset>,<f_offset> 504

[[:SENSe]:SEMAsk:OFFSet[n]:LIST:FREQuency:START? 504

[[:SENSe]:SEMAsk:OFFSet[n]:LIST:FREQuency:STEP
<f_offset>,<f_offset>,<f_offset>,<f_offset>,<f_offset> 505

[[:SENSe]:SEMAsk:OFFSet[n]:LIST:FREQuency:STEP:AUTO
OFF | ON | 0 | 1,OFF | ON | 0 | 1,OFF | ON | 0 | 1,OFF | ON | 0 | 1,OFF | ON | 0 | 1 505

[[:SENSe]:SEMAsk:OFFSet[n]:LIST:FREQuency:STEP:AUTO? 505

[[:SENSe]:SEMAsk:OFFSet[n]:LIST:FREQuency:STEP? 505

[[:SENSe]:SEMAsk:OFFSet[n]:LIST:FREQuency:STOP
<f_offset>,<f_offset>,<f_offset>,<f_offset>,<f_offset> 506

[[:SENSe]:SEMAsk:OFFSet[n]:LIST:FREQuency:STOP? 506

[[:SENSe]:SEMAsk:OFFSet[n]:LIST:RATTenuation
<rel_power>,<rel_power>,<rel_power>,<rel_power>,<rel_power> 507

[[:SENSe]:SEMAsk:OFFSet[n]:LIST:RATTenuation? 507

[[:SENSe]:SEMAsk:OFFSet[n]:LIST:SIDE BOTH | NEGative | POSitive,

Commands

BOTH | NEGative | POSitive, BOTH | NEGative | POSitive, BOTH | NEGative | POSitive, BOTH | NEGative | POSitive 508

[[:SENSe]:SEMAsk:OFFSet[n]:LIST:SIDE? 508

[[:SENSe]:SEMAsk:OFFSet[n]:LIST:START:ABSolute
<abs_power>, <abs_power>, <abs_power>, <abs_power>, <abs_power> 509

[[:SENSe]:SEMAsk:OFFSet[n]:LIST:START:ABSolute? 509

[[:SENSe]:SEMAsk:OFFSet[n]:LIST:START:RCARrier
<rel_power>, <rel_power>, <rel_power>, <rel_power>, <rel_power> 510

[[:SENSe]:SEMAsk:OFFSet[n]:LIST:START:RCARrier? 510

[[:SENSe]:SEMAsk:OFFSet[n]:LIST:STATe
OFF | ON | 0 | 1, OFF | ON | 0 | 1, OFF | ON | 0 | 1, OFF | ON | 0 | 1, OFF | ON | 0 | 1 511

[[:SENSe]:SEMAsk:OFFSet[n]:LIST:STATe? 511

[[:SENSe]:SEMAsk:OFFSet[n]:LIST:STOP:ABSolute
<abs_power>, <abs_power>, <abs_power>, <abs_power>, <abs_power> 512

[[:SENSe]:SEMAsk:OFFSet[n]:LIST:STOP:ABSolute:COUPle
OFF | ON | 0 | 1, OFF | ON | 0 | 1, OFF | ON | 0 | 1, OFF | ON | 0 | 1, OFF | ON | 0 | 1 513

[[:SENSe]:SEMAsk:OFFSet[n]:LIST:STOP:ABSolute:COUPle? 513

[[:SENSe]:SEMAsk:OFFSet[n]:LIST:STOP:ABSolute? 512

[[:SENSe]:SEMAsk:OFFSet[n]:LIST:STOP:RCARrier
<rel_power>, <rel_power>, <rel_power>, <rel_power>, <rel_power> 514

[[:SENSe]:SEMAsk:OFFSet[n]:LIST:STOP:RCARrier:COUPle
OFF | ON | 0 | 1, OFF | ON | 0 | 1, OFF | ON | 0 | 1, OFF | ON | 0 | 1, OFF | ON | 0 | 1 515

[[:SENSe]:SEMAsk:OFFSet[n]:LIST:STOP:RCARrier:COUPle? 515

[[:SENSe]:SEMAsk:OFFSet[n]:LIST:STOP:RCARrier? 514

[[:SENSe]:SEMAsk:OFFSet[n]:LIST:TEST
ABSolute | AND | OR | RELative, ABSolute | AND | OR | RELative,
ABSolute | AND | OR | RELative, ABSolute | AND | OR | RELative,
ABSolute | AND | OR | RELative 516

[[:SENSe]:SEMAsk:OFFSet[n]:LIST:TEST? 516

[[:SENSe]:SEMAsk:REGion:LIST:BANDwidth | BWIDth
<res_bw>, <res_bw>, <res_bw>, <res_bw>, <res_bw> 517

[[:SENSe]:SEMAsk:REGion:LIST:BANDwidth | BWIDth:AUTO
OFF | ON | 0 | 1, OFF | ON | 0 | 1, OFF | ON | 0 | 1, OFF | ON | 0 | 1, OFF | ON | 0 | 1 518

[[:SENSe]:SEMAsk:REGion:LIST:BANDwidth | BWIDth:AUTO? 518

[[:SENSe]:SEMAsk:REGion:LIST:BANDwidth | BWIDth? 517

[[:SENSe]:SEMAsk:REGion:LIST:FREQuency:START

Commands

<f_region>,<f_region>,<f_region>,<f_region>,<f_region> 519

[[:SENSe]:SEMAsk:REGion:LIST:FREQuency:START? 519

[[:SENSe]:SEMAsk:REGion:LIST:FREQuency:STEP
<f_region>,<f_region>,<f_region>,<f_region>,<f_region> 520

[[:SENSe]:SEMAsk:REGion:LIST:FREQuency:STEP:AUTO
OFF | ON | 0 | 1,OFF | ON | 0 | 1,OFF | ON | 0 | 1,OFF | ON | 0 | 1,OFF | ON | 0 | 1 520

[[:SENSe]:SEMAsk:REGion:LIST:FREQuency:STEP:AUTO? 520

[[:SENSe]:SEMAsk:REGion:LIST:FREQuency:STEP? 520

[[:SENSe]:SEMAsk:REGion:LIST:FREQuency:STOP
<f_region>,<f_region>,<f_region>,<f_region>,<f_region> 521

[[:SENSe]:SEMAsk:REGion:LIST:FREQuency:STOP? 521

[[:SENSe]:SEMAsk:REGion:LIST:RATTenuation
<rel_power>,<rel_power>,<rel_power>,<rel_power>,<rel_power> 522

[[:SENSe]:SEMAsk:REGion:LIST:RATTenuation? 522

[[:SENSe]:SEMAsk:REGion:LIST:STARt:ABSolute
<abs_power>,<abs_power> 523

[[:SENSe]:SEMAsk:REGion:LIST:STARt:ABSolute? 523

[[:SENSe]:SEMAsk:REGion:LIST:STARt:RCARrier
<rel_power>,<rel_power>,<rel_power>,<rel_power>,<rel_power> 524

[[:SENSe]:SEMAsk:REGion:LIST:STARt:RCARrier? 524

[[:SENSe]:SEMAsk:REGion:LIST:STATe
OFF | ON | 0 | 1,OFF | ON | 0 | 1,OFF | ON | 0 | 1,OFF | ON | 0 | 1,OFF | ON | 0 | 1 525

[[:SENSe]:SEMAsk:REGion:LIST:STATe? 525

[[:SENSe]:SEMAsk:REGion:LIST:STOP:ABSolute
<abs_power>,<abs_power>,<abs_power>,<abs_power>,<abs_power> 525

[[:SENSe]:SEMAsk:REGion:LIST:STOP:ABSolute? 525

[[:SENSe]:SEMAsk:REGion:LIST:STOP:RCARrier
<rel_power>,<rel_power>,<rel_power>,<rel_power>,<rel_power> 527

[[:SENSe]:SEMAsk:REGion:LIST:STOP:RCARrier:COUple
OFF | ON | 0 | 1,OFF | ON | 0 | 1,OFF | ON | 0 | 1,OFF | ON | 0 | 1,OFF | ON | 0 | 1 528

[[:SENSe]:SEMAsk:REGion:LIST:STOP:RCARrier:COUple? 528

[[:SENSe]:SEMAsk:REGion:LIST:STOP:RCARrier? 527

[[:SENSe]:SEMAsk:REGion:LIST:TEST ABSolute | AND | OR | RELative,ABSolute | AND | OR | RELative,
ABSolute | AND | OR | RELative,ABSolute | AND | OR | RELative,
ABSolute | AND | OR | RELative 528

Commands

[[:SENSe]:SEMAsk:REGion:LIST:TEST? 528

[[:SENSe]:SEMAsk:REGion[n]:LIST:BANDwidth | BWIDth
<res_bw>,<res_bw>,<res_bw>,<res_bw>,<res_bw> 517

[[:SENSe]:SEMAsk:REGion[n]:LIST:BANDwidth | BWIDth:AUTO
OFF | ON | 0 | 1,OFF | ON | 0 | 1,OFF | ON | 0 | 1,OFF | ON | 0 | 1,OFF | ON | 0 | 1 518

[[:SENSe]:SEMAsk:REGion[n]:LIST:BANDwidth | BWIDth:AUTO? 518

[[:SENSe]:SEMAsk:REGion[n]:LIST:BANDwidth | BWIDth? 517

[[:SENSe]:SEMAsk:REGion[n]:LIST:FREQuency:STARt
<f_region>,<f_region>,<f_region>,<f_region>,<f_region> 519

[[:SENSe]:SEMAsk:REGion[n]:LIST:FREQuency:STARt? 519

[[:SENSe]:SEMAsk:REGion[n]:LIST:FREQuency:STEP
<f_region>,<f_region>,<f_region>,<f_region>,<f_region> 520

[[:SENSe]:SEMAsk:REGion[n]:LIST:FREQuency:STEP:AUTO
OFF | ON | 0 | 1,OFF | ON | 0 | 1,OFF | ON | 0 | 1,OFF | ON | 0 | 1,OFF | ON | 0 | 1 520

[[:SENSe]:SEMAsk:REGion[n]:LIST:FREQuency:STEP:AUTO? 520

[[:SENSe]:SEMAsk:REGion[n]:LIST:FREQuency:STEP? 520

[[:SENSe]:SEMAsk:REGion[n]:LIST:FREQuency:STOP
<f_region>,<f_region>,<f_region>,<f_region>,<f_region> 521

[[:SENSe]:SEMAsk:REGion[n]:LIST:FREQuency:STOP? 521

[[:SENSe]:SEMAsk:REGion[n]:LIST:RATTenuation
<rel_power>,<rel_power>,<rel_power>,<rel_power>,<rel_power> 522

[[:SENSe]:SEMAsk:REGion[n]:LIST:RATTenuation? 522

[[:SENSe]:SEMAsk:REGion[n]:LIST:STARt:ABSolute
<abs_power>,<abs_power> 523

[[:SENSe]:SEMAsk:REGion[n]:LIST:STARt:ABSolute? 523

[[:SENSe]:SEMAsk:REGion[n]:LIST:STARt:RCARrier
<rel_power>,<rel_power>,<rel_power>,<rel_power>,<rel_power> 524

[[:SENSe]:SEMAsk:REGion[n]:LIST:STARt:RCARrier? 524

[[:SENSe]:SEMAsk:REGion[n]:LIST:STATe
OFF | ON | 0 | 1,OFF | ON | 0 | 1,OFF | ON | 0 | 1,OFF | ON | 0 | 1,OFF | ON | 0 | 1 524

[[:SENSe]:SEMAsk:REGion[n]:LIST:STATe? 525

[[:SENSe]:SEMAsk:REGion[n]:LIST:STOP:ABSolute
<abs_power>,<abs_power>,<abs_power>,<abs_power>,<abs_power> 525

[[:SENSe]:SEMAsk:REGion[n]:LIST:STOP:ABSolute:COUple
OFF | ON | 0 | 1,OFF | ON | 0 | 1 526

Commands

[[:SENSe]:SEMAsk:REGion[n]:LIST:STOP:ABSolute:COUPle? 526
[:SENSe]:SEMAsk:REGion[n]:LIST:STOP:ABSolute? 525
[:SENSe]:SEMAsk:REGion[n]:LIST:STOP:RCARrier
<rel_power>,<rel_power>,<rel_power>,<rel_power>,<rel_power> 527
[:SENSe]:SEMAsk:REGion[n]:LIST:STOP:RCARrier:COUPle
OFF | ON | 0 | 1,OFF | ON | 0 | 1,OFF | ON | 0 | 1,OFF | ON | 0 | 1,OFF | ON | 0 | 1 527
[:SENSe]:SEMAsk:REGion[n]:LIST:STOP:RCARrier:COUPle? 528
[:SENSe]:SEMAsk:REGion[n]:LIST:STOP:RCARrier? 527
[:SENSe]:SEMAsk:REGion[n]:LIST:TEST ABSolute | AND | OR | RELative,ABSolute | AND | OR | RELative,
ABSolute | AND | OR | RELative,ABSolute | AND | OR | RELative,
ABSolute | AND | OR | RELative 528
[:SENSe]:SEMAsk:REGion[n]:LIST:TEST? 528
[:SENSe]:SEMAsk:SEGMENT OFFSet | REGion 529
[:SENSe]:SEMAsk:SEGMENT:TYPE ACPr | SEMAsk 530
[:SENSe]:SEMAsk:SEGMENT:TYPE? 530
[:SENSe]:SEMAsk:SEGMENT? 529
[:SENSe]:SEMAsk:SWEep:TIME <time> | <no. of chips> 530
[:SENSe]:SEMAsk:SWEep:TIME:OFFSet <time> | <no. of chips> 530
[:SENSe]:SEMAsk:SWEep:TIME:OFFSet? 530
[:SENSe]:SEMAsk:SWEep:TIME? 530
[:SENSe]:SEMAsk:TRIGger:SOURce EXTernal[1] | EXTernal2 | FRAME | IMMEDIATE | LINE 531
[:SENSe]:SEMAsk:TRIGger:SOURce? 531
[:SENSe]:SEMAsk:TYPE PSDRef 531
[:SENSe]:SEMAsk:TYPE? 531
[:SENSe]:SPECtrum:ACQuisition:PACKing AUTO | LONG | MEDium | SHORt 532
[:SENSe]:SPECtrum:ACQuisition:PACKing? 532
[:SENSe]:SPECtrum:ADC:DITHer[:STATe] AUTO | ON | OFF | 2 | 1 | 0 532
[:SENSe]:SPECtrum:ADC:DITHer[:STATe]? 532
[:SENSe]:SPECtrum:ADC:RANGe AUTO | APEak | APLOCK | M6 | P0 | P6 | P12 | P18 | P24 532
[:SENSe]:SPECtrum:ADC:RANGe AUTO | APEak | APLOCK | NONE | P0 | P6 | P12 | P18 532
[:SENSe]:SPECtrum:ADC:RANGe? 533
[:SENSe]:SPECtrum:AVERage:CLEar 534

Commands

[[:SENSe]:SPECTrum:AVERAge:COUNT <integer> 534
[:SENSe]:SPECTrum:AVERAge:COUNT? 534
[:SENSe]:SPECTrum:AVERAge:TCONtrol EXPONential | REPeat 535
[:SENSe]:SPECTrum:AVERAge:TCONtrol? 535
[:SENSe]:SPECTrum:AVERAge:TYPE LOG | MAXimum | MINimum | RMS | SCALar 535
[:SENSe]:SPECTrum:AVERAge:TYPE? 535
[:SENSe]:SPECTrum:AVERAge[:STATe] OFF | ON | 0 | 1 534
[:SENSe]:SPECTrum:AVERAge[:STATe]? 534
[:SENSe]:SPECTrum:Bandwidth | BWIDth:IF:AUTO OFF | ON | 0 | 1 536
[:SENSe]:SPECTrum:Bandwidth | BWIDth:IF:AUTO? 536
[:SENSe]:SPECTrum:Bandwidth | BWIDth:IF:FLATness OFF | ON | 0 | 1 536
[:SENSe]:SPECTrum:Bandwidth | BWIDth:IF:FLATness? 536
[:SENSe]:SPECTrum:Bandwidth | BWIDth:PADC OFF | ON | 0 | 1 536
[:SENSe]:SPECTrum:Bandwidth | BWIDth:PADC? 536
[:SENSe]:SPECTrum:Bandwidth | BWIDth:PFFT:TYPE FLAT | GAUSSian 537
[:SENSe]:SPECTrum:Bandwidth | BWIDth:PFFT:TYPE? 537
[:SENSe]:SPECTrum:Bandwidth | BWIDth:PFFT[:SIZE] <freq> 537
[:SENSe]:SPECTrum:Bandwidth | BWIDth:PFFT[:SIZE]? 537
[:SENSe]:SPECTrum:Bandwidth | BWIDth[:RESolution] <freq> 538
[:SENSe]:SPECTrum:Bandwidth | BWIDth[:RESolution]:AUTO OFF | ON | 0 | 1 538
[:SENSe]:SPECTrum:Bandwidth | BWIDth[:RESolution]:AUTO? 538
[:SENSe]:SPECTrum:Bandwidth | BWIDth[:RESolution]? 538
[:SENSe]:SPECTrum:DECimate[:FACTor] <integer> 538
[:SENSe]:SPECTrum:DECimate[:FACTor]? 539
[:SENSe]:SPECTrum:FFT:LENGth <integer> 539
[:SENSe]:SPECTrum:FFT:LENGth:AUTO OFF | ON | 0 | 1 540
[:SENSe]:SPECTrum:FFT:LENGth:AUTO? 540
[:SENSe]:SPECTrum:FFT:LENGth? 539
[:SENSe]:SPECTrum:FFT:RBWPoints <real> 540
[:SENSe]:SPECTrum:FFT:RBWPoints? 540
[:SENSe]:SPECTrum:FFT:WINDow:DELay <real> 541

Commands

[[:SENSe]:SPEcTrum:FFT:WINDow:DELay? 541
[:SENSe]:SPEcTrum:FFT:WINDow:LENGth <integer> 541
[:SENSe]:SPEcTrum:FFT:WINDow:LENGth? 541
[:SENSe]:SPEcTrum:FFT:WINDow[:TYPE] BH4Tap | BLACKman | FLATtop | GAUSSian | HAM-
Ming | HANNing | KB70 | KB90 | KB110 | UNIFORM 541
[:SENSe]:SPEcTrum:FFT:WINDow[:TYPE]? 541
[:SENSe]:SPEcTrum:FREQuency:SPAN <freq> 542
[:SENSe]:SPEcTrum:FREQuency:SPAN? 542
[:SENSe]:SPEcTrum:SWEep:TIME:AUTO 543
[:SENSe]:SPEcTrum:SWEep:TIME:AUTO OFF | ON | 0 | 1 543
[:SENSe]:SPEcTrum:SWEep:TIME? 543
[:SENSe]:SPEcTrum:SWEep:TIME[:VALue] <time> 543
[:SENSe]:SPEcTrum:TRIGger:SOURce EXTernal[1] | EXTernal2 | FRAME | IF | LINE | IMMEdi-
ate | RFBurst 543
[:SENSe]:SPEcTrum:TRIGger:SOURce? 544
[:SENSe]:SYNC ESECond | EXTernal[1] | EXTernal2 | NONE | PSEQUence 545
[:SENSe]:SYNC:ALIGNment GSM | HBIT 545
[:SENSe]:SYNC:ALIGNment? 545
[:SENSe]:SYNC:BURSt:DELay <time> 546
[:SENSe]:SYNC:BURSt:DELay? 546
[:SENSe]:SYNC:BURSt:RFAMplitude:DELay <time> 546
[:SENSe]:SYNC:BURSt:RFAMplitude:DELay? 546
[:SENSe]:SYNC:BURSt:STHReshold <rel_power> 546
[:SENSe]:SYNC:BURSt:STHReshold? 546
[:SENSe]:SYNC:STHReshold <rel_power> 547
[:SENSe]:SYNC:STHReshold? 547
[:SENSe]:SYNC? 545
[:SENSe]:TCDPower:ACODE AUTO | COMBination | PREDefined 548
[:SENSe]:TCDPower:ACODE:ACK OFF | ON | 0 | 1 548
[:SENSe]:TCDPower:ACODE:ACK? 548
[:SENSe]:TCDPower:ACODE:DATA OFF | ON | 0 | 1 548
[:SENSe]:TCDPower:ACODE:DATA? 548

Commands

[:SENSe]:TCDPower:ACODE:DRC OFF | ON | 0 | 1 549
[:SENSe]:TCDPower:ACODE:DRC? 549
[:SENSe]:TCDPower:ACODE:PILOt OFF | ON | 0 | 1 549
[:SENSe]:TCDPower:ACODE:PILOt? 549
[:SENSe]:TCDPower:ACODE? 548
[:SENSe]:TCDPower:ADC:RANGe AUTO | APEak | APLock | NONE | P0 | P6 | P12 | P18 | P24 | M6 549
[:SENSe]:TCDPower:ADC:RANGe? 549
[:SENSe]:TCDPower:CAPTure:TIME <integer> 550
[:SENSe]:TCDPower:CAPTure:TIME? 550
[:SENSe]:TCDPower:CRATe <freq> 551
[:SENSe]:TCDPower:CRATe? 551
[:SENSe]:TCDPower:SPECTrum NORMal | INVert 551
[:SENSe]:TCDPower:SPECTrum? 551
[:SENSe]:TCDPower:SYNC:ILCMask <long_integer> 552
[:SENSe]:TCDPower:SYNC:ILCMask? 552
[:SENSe]:TCDPower:SYNC:QLCMask <long_integer> 552
[:SENSe]:TCDPower:SYNC:QLCMask? 552
[:SENSe]:TCDPower:TRIGger:SOURce EXTernal[1] | EXTernal2 | IMMEDIATE | RF-
Burst | IF | FRAME 551
[:SENSe]:TCDPower:TRIGger:SOURce? 551
[:SENSe]:TRHO:ACODE AUTO | COMBination | PREDefined 556
[:SENSe]:TRHO:ACODE:ACK OFF | ON | 0 | 1 556
[:SENSe]:TRHO:ACODE:ACK? 556
[:SENSe]:TRHO:ACODE:DATA OFF | ON | 0 | 1 556
[:SENSe]:TRHO:ACODE:DATA? 556
[:SENSe]:TRHO:ACODE:DRC OFF | ON | 0 | 1 557
[:SENSe]:TRHO:ACODE:DRC? 557
[:SENSe]:TRHO:ACODE:PILOt OFF | ON | 0 | 1 557
[:SENSe]:TRHO:ACODE:PILOt? 557
[:SENSe]:TRHO:ACODE? 556
[:SENSe]:TRHO:ADC:RANGe AUTO | APEak | APLock | NONE | P0 | P6 | P12 | P18 | P24 | M6 557

Commands

[[:SENSe]:TRHO:ADC:RANGe? 557
[:SENSe]:TRHO:ASET:THReshold <numeric> 558
[:SENSe]:TRHO:ASET:THReshold? 558
[:SENSe]:TRHO:AVERAge:COUNT <integer> 559
[:SENSe]:TRHO:AVERAge:COUNT? 559
[:SENSe]:TRHO:AVERAge:TCONtrol EXPOnential | REPeat 559
[:SENSe]:TRHO:AVERAge:TCONtrol? 559
[:SENSe]:TRHO:AVERAge[:STATe] OFF | ON | 0 | 1 559
[:SENSe]:TRHO:AVERAge[:STATe] OFF | ON | 0 | 1 560
[:SENSe]:TRHO:AVERAge[:STATe]? 559
[:SENSe]:TRHO:AVERAge[:STATe]? 560
[:SENSe]:TRHO:CRATe <freq> 560
[:SENSe]:TRHO:CRATe? 560
[:SENSe]:TRHO:SPECtrum NORMAl | INVert 560
[:SENSe]:TRHO:SPECtrum? 560
[:SENSe]:TRHO:SYNC:ILCMask <long_integer> 560
[:SENSe]:TRHO:SYNC:ILCMask? 560
[:SENSe]:TRHO:SYNC:QLCMask <long_integer> 561
[:SENSe]:TRHO:SYNC:QLCMask? 561
[:SENSe]:TRHO:TRIGger:SOURce EXTernal[1] | EXTernal2 | IMMEDIATE | RFBurst | IF | FRAME 561
[:SENSe]:TRHO:TRIGger:SOURce? 561
[:SENSe]:TSPur:AVERAge:COUNT <integer> 553
[:SENSe]:TSPur:AVERAge:COUNT? 553
[:SENSe]:TSPur:AVERAge:TCONtrol EXPOnential | REPeat 553
[:SENSe]:TSPur:AVERAge:TCONtrol? 553
[:SENSe]:TSPur:AVERAge:TYPE LOG | MAXimum | RMS 554
[:SENSe]:TSPur:AVERAge:TYPE? 554
[:SENSe]:TSPur:AVERAge[:STATe] OFF | ON | 0 | 1 553
[:SENSe]:TSPur:AVERAge[:STATe]? 553
[:SENSe]:TSPur:TYPE EXAMine | FULL 554
[:SENSe]:TSPur:TYPE? 554

Commands

[[:SENSe]:TXPower:AVERAge:COUNT <integer> 562
[:SENSe]:TXPower:AVERAge:COUNT? 562
[:SENSe]:TXPower:AVERAge:TCONtrol EXPonential | REPeat 562
[:SENSe]:TXPower:AVERAge:TCONtrol? 562
[:SENSe]:TXPower:AVERAge:TYPE | LOG | MAX | MIN | RMS 563
[:SENSe]:TXPower:AVERAge:TYPE? 563
[:SENSe]:TXPower:AVERAge[:STATe] OFF | ON | 0 | 1 562
[:SENSe]:TXPower:AVERAge[:STATe]? 562
[:SENSe]:TXPower:BANDwidth | BWIDth[:RESolution] <freq> 563
[:SENSe]:TXPower:BANDwidth | BWIDth[:RESolution]:TYPE FLAT | GAUSSian 563
[:SENSe]:TXPower:BANDwidth | BWIDth[:RESolution]:TYPE? 563
[:SENSe]:TXPower:BANDwidth | BWIDth[:RESolution]? 563
[:SENSe]:TXPower:SWEep:TIME <integer> 564
[:SENSe]:TXPower:SWEep:TIME? 564
[:SENSe]:TXPower:THReshold <power> 564
[:SENSe]:TXPower:THReshold:TYPE ABSolute | RELative 565
[:SENSe]:TXPower:THReshold:TYPE? 565
[:SENSe]:TXPower:THReshold? 564
[:SENSe]:TXPower:TRIGger:SOURce EXTernal[1] | EXTernal2 | IF | IMMEDIATE | RFBurst 565
[:SENSe]:TXPower:TRIGger:SOURce? 565
[:SENSe]:VOLTage:IQ:RANGe[:UPPer] <level> 346
[:SENSe]:VOLTage:IQ:RANGe[:UPPer]<Float 64> [V] 450
[:SENSe]:VOLTage:IQ:RANGe[:UPPer]? 346
[:SENSe]:VOLTage:IQ:RANGe[:UPPer]? 450
[:SENSe]:WAVeform:ACQuisition:PACKing AUTO | LONG | MEDium | SHORt 566
[:SENSe]:WAVeform:ACQuisition:PACKing? 566
[:SENSe]:WAVeform:ADC:DITHer[:STATe] OFF | ON | 0 | 1 566
[:SENSe]:WAVeform:ADC:DITHer[:STATe]? 566
[:SENSe]:WAVeform:ADC:FILTer[:STATe] OFF | ON | 0 | 1 566
[:SENSe]:WAVeform:ADC:FILTer[:STATe]? 566
[:SENSe]:WAVeform:ADC:RANGe AUTO | APEak | APLock | GROund | M6 | P0 | P6 | P12 | P18 | P24

Commands

567

[[:SENSe]:WAVeform:ADC:RANGe AUTO | APEak | APLock | GROund | NONE | P0 | P6 | P12 | P18 567

[[:SENSe]:WAVeform:ADC:RANGe? 567

[[:SENSe]:WAVeform:APERture? 567

[[:SENSe]:WAVeform:AVERage:COUNt <integer> 568

[[:SENSe]:WAVeform:AVERage:COUNt? 568

[[:SENSe]:WAVeform:AVERage:TCONtrol EXPonential | REPEAT 568

[[:SENSe]:WAVeform:AVERage:TCONtrol? 568

[[:SENSe]:WAVeform:AVERage:TYPE LOG | MAXimum | MINimum | RMS | SCALar 569

[[:SENSe]:WAVeform:AVERage:TYPE? 569

[[:SENSe]:WAVeform:AVERage[:STATe] OFF | ON | 0 | 1 568

[[:SENSe]:WAVeform:AVERage[:STATe]? 568

[[:SENSe]:WAVeform:BANDwidth:RESolution]:ACTual? 570

[[:SENSe]:WAVeform:BANDwidth | BWIDth[:RESolution] <freq> 569

[[:SENSe]:WAVeform:BANDwidth | BWIDth[:RESolution]:TYPE FLATtop | GAUSSian 570

[[:SENSe]:WAVeform:BANDwidth | BWIDth[:RESolution]:TYPE? 570

[[:SENSe]:WAVeform:BANDwidth | BWIDth[:RESolution]? 569

[[:SENSe]:WAVeform:DECimate:STATe OFF | ON | 0 | 1 571

[[:SENSe]:WAVeform:DECimate:STATe? 571

[[:SENSe]:WAVeform:DECimate[:FACTor] <integer> 571

[[:SENSe]:WAVeform:DECimate[:FACTor]? 571

[[:SENSe]:WAVeform:SWEep:TIME <time> 572

[[:SENSe]:WAVeform:SWEep:TIME? 572

[[:SENSe]:WAVeform:TRIGger:SOURce EXTernal[1] |
EXTernal2 | FRAME | IF | IMMEDIATE | LINE | RFBurst 572

[[:SENSe]:WAVeform:TRIGger:SOURce? 572

DISPlay:TRHO:VIEW POLar | ERRor | TABLE 168

DISPlay:TRHO:VIEW? 168

Common IEEE Commands

These commands are specified in IEEE Standard 488.2-1992, *IEEE Standard Codes, Formats, Protocols and Common Commands for Use with ANSI/IEEE Std 488.1-1987*. New York, NY, 1992.

Numeric values for bit patterns can be entered using decimal or hexadecimal representations. (i.e. 0 to 32767 is equivalent to #H0 to #H7FFF) See the SCPI Basics information about using bit patterns for variable parameters.

Calibration Query

*CAL?

Performs a full alignment and returns a number indicating the success of the alignment. A zero is returned if the alignment is successful. A one is returned if any part of the alignment fails. The equivalent SCPI command is CALibrate[:ALL]?

Front Panel

Access: **System, Alignments, Align All Now**

Clear Status

*CLS

Clears the status byte. It does this by emptying the error queue and clearing all bits in all of the event registers. The status byte registers summarize the states of the other registers. It is also responsible for generating service requests.

Key Type: There is no equivalent front panel key.

Standard Event Status Enable

*ESE <number>

*ESE?

Selects the desired bits from the standard event status enable register. This register monitors I/O errors and synchronization conditions such as operation complete, request control, query error, device dependent error, execution error, command error and power on. The selected bits are OR'd to become a summary bit (bit 5) in the status byte register which can be queried.

The query returns the state of the standard event status enable register.

Key Type: There is no equivalent front panel key.

Range: Integer, 0 to 255

Standard Event Status Register Query

*ESR?

Queries and clears the standard event status event register. (This is a destructive read.)

Key Type: There is no equivalent front panel key.

Range: Integer, 0 to 255

Identification Query

*IDN?

Returns an instrument identification information. The string will contain the model number, serial number and firmware revision.

The response is organized into four fields separated by commas. The field definitions are as follows:

- Manufacturer
- Model
- Serial number
- Firmware version

For example:

Agilent Technologies,E4406A,US00000040,A.01.42 (for E4406A)

Key Type: There is no equivalent front panel key.

Remarks: An @ in the firmware revision information indicates that it is proto firmware.

Front Panel

Access: **System, Show System**

Instrument State Query

*LRN?

For VSA: Returns current instrument state data in a block of defined length. The <state data> is in a machine readable format only. Sending the query returns the following format:

```
#PQQSYST:SET #NMMM<state_data>
```

The following example is a response to ***LRN?** The actual sizes will vary depending on

the instrument state data size.

Example: #42031SYST:SET #42016<state data>

The number 4 (P in the preceding query response format) means there are 4 numbers that make up the size of the data that follows. In this example, 2031 bytes will follow the number 4 (42031).

2031 and 2016 (QQQ and MMM in the preceding query response format) represent data size in bytes.

The state can be changed by sending this block of data to the instrument after removing the size information:

Example: SYST:SET #NMMM<state_data>

Operation Complete

***OPC**

***OPC?**

The *OPC command sets bit 0 in the standard event status register to “1” when pending operations have finished. It does not hold off subsequent operations.

The *OPC? query stops new commands from being processed until the current processing is complete. Then it returns a “1”, and the program continues. This query can be used to synchronize events of other instruments on the external bus.

The instrument default is to only wait for completion of the internal self-alignment routines. You must set the STATus:OPERation:EVENT register if you want to look for the completion of additional processes such as:

VSA Process	STATus:OPER Register Bit	Byte Value
Calibrating	0	1
Sweeping	3	8
Waiting for trigger	5	32
Paused	8	256
Printing	11	2048
Mass memory access (floppy drive)	12	4096

Key Type: There is no equivalent front panel key.

Query Instrument Options

*OPT?

Returns a string of all the installed instrument options. It is a comma separated list such as: "BAC,BAH". There are a few options that include more than one mode. An instrument with one of these options will report the option number once for each mode. You would get a response: "BAC,BAE,BAE,BAH" For an instrument that contains cdmaOne (BAC), NADC (BAE), PDC (BAE), and GSM (BAH).

Recall

*RCL <register>

This command recalls the instrument state from the specified instrument memory register.

Key Type: There is no equivalent front panel key.
Range: registers are an integer, 0 to 19 (for E4406A)
Example: *RCL 12
Front Panel
Access: **File, Recall State**

Reset

*RST

This command presets the instrument to a factory defined condition that is appropriate for remote programming operation. *RST is equivalent to performing the commands

- **:SYSTem:PRESet**, with preset type set to MODE.
- ***CLS** which clears the STATus bits and error queue
- **:INITiate:CONTinuous OFF** which selects single sweep/measurement

*RST does not change the mode and *only* resets the parameters for the current mode.

The **:SYSTem:PRESet** command is equivalent to a front panel **Preset**. The front panel **Preset** sets instrument parameters to values for good front panel usage in the current mode. The *RST and front panel **Preset** will be different. For example, the *RST will place the instrument in single sweep while the front panel **Preset** will place the instrument in continuous sweep.

Key Type: There is no equivalent front panel key.

Save

***SAV <register>**

This command saves the instrument state to the specified instrument memory register.

Key Type: There is no equivalent front panel key.
 Range: Registers are an integer, 0 to 19 (for E4406A)
 Example: *SAV 12
 Front Panel
 Access: **File, Save State**

Service Request Enable

***SRE <integer>**

***SRE?**

This command sets the value of the service request enable register.

The query returns the value of the register.

Key Type: There is no equivalent front panel key.
 Range: Integer, 0 to 63, or 128 to 191 (for E4406A)
 Example: *SRE 22

Read Status Byte Query

***STB?**

Returns the value of the status byte register without erasing its contents.

Key Type: There is no equivalent front panel key.
 Remarks: See ***CLS**

Trigger

***TRG**

This command triggers the instrument. Use the **:TRIGger[:SEQuence]:SOURce** command to select the trigger source.

The desired measurement has been selected and is waiting. The command causes the system to exit this “waiting” state and go to the “initiated” state. The trigger system is initiated and completes one full trigger cycle. It returns to the “waiting”

Common IEEE Commands

state on completion of the trigger cycle. See the MEASure subsystem for more information about controlling the measurement process.

The instrument must be in the single measurement mode. If INIT:CONT ON, then the command is ignored. Depending upon the measurement and the number of averages, there may be multiple data acquisitions, with multiple trigger events, for one full trigger cycle.

Key Type: There is no equivalent front panel key.
Remarks: See also the **:INITiate:IMMediate** command
Front Panel
Access: **Restart**

Self Test Query

*TST?

This query performs a full self alignment and returns a number indicating the success of the alignment. A zero is returned if the alignment is successful. Same as CAL[:ALL]? and *CAL?

Key Type: There is no equivalent front panel key.
Front Panel
Access: **System, Alignments, Align All Now**

Wait-to-Continue

*WAI

This command causes the instrument to wait until all pending commands/processes are completed before executing any additional commands. There is no query form for the command.

The instrument default is to only wait for completion of the internal self-alignment routines. You must set the STATus:OPERation:EVENT register if you want to look for the completion of additional processes. See the *OPC? command for more information.

Key Type: There is no equivalent front panel key.
Example: INIT:CONT OFF; INIT;*WAI

ABORt Subsystem

Abort Command

:ABORt

Stops any sweep or measurement in progress and resets the sweep or trigger system. A measurement refers to any of the measurements found in the **MEASURE** menu.

If **:INITiate:CONTinuous** is off (single measure), then **:INITiate:IMMediate** will start a new single measurement.

If **:INITiate:CONTinuous** is on (continuous measure), a new continuous measurement begins immediately.

The **INITiate** and/or **TRIGger** subsystems contain additional related commands.

Front Panel

Access: For the continuous measurement mode, the **Restart** key is equivalent to **ABORt**.

ABORt Subsystem

CALCulate Subsystem

This subsystem is used to perform post-acquisition data processing. In effect, the collection of new data triggers the CALCulate subsystem. In this instrument, the primary functions in this subsystem are markers and limits.

The SCPI default for data output format is ASCII. The format can be changed to binary with FORMat:DATA which transports faster over the bus.

ACP - Limits

Adjacent Channel Power—Limit Test

```
:CALCulate:ACP:LIMit:STATe OFF|ON|0|1
```

```
:CALCulate:ACP:LIMit:STATe?
```

Turn limit test on or off.

Factory Preset: On

Remarks: For E4406A you must be in Basic, cdmaOne, iDEN mode to use this command. Use INSTRument:SElect to set the mode.

For PSA you must be in cdmaOne mode to use this command.
Use INSTRument:SElect to set the mode.

Adjacent Channel Power—Limit Test

```
:CALCulate:ACP:LIMit[:TEST] OFF|ON|0|1
```

```
:CALCulate:ACP:LIMit[:TEST]?
```

Turn limit test on or off.

Factory Preset: On

Remarks: You must be in the NADC, PDC mode to use this command.
Use INSTRument:SElect to set the mode.

CALCulate Subsystem

BER - Limits

Bit Error Rate—Frame Count

:CALCulate:BER:FRAMes <integer>

:CALCulate:BER:FRAMes?

Indicates the number of frames to be used for calculating the bit error rate.

Factory Preset: 16

Factory Preset: 1 to 1024 frames

Remarks: You must be in the iDEN mode to use this command. Use INSTRument:SElect to set the mode.

History: Version A.03.00 or later

Bit Error Rate—Error Limit

:CALCulate:BER:LIMit:ERATe <percent>

:CALCulate:BER:LIMit:ERATe?

Set the percent error limit on the bit error rate.

Factory Preset: 5%

Range: 0.1 to 20%

Default Unit: Hz

Remarks: You must be in the iDEN mode to use this command. Use INSTRument:SElect to set the mode.

History: Version A.03.00 or later

Bit Error Rate—Limit Testing

:CALCulate:BER:LIMit:STATe OFF|ON|0|1

:CALCulate:BER:LIMit:STATe?

Turn limit testing on or off.

Factory Preset: On

Remarks: You must be in the iDEN mode to use this command. Use INSTRument:SElect to set the mode.

History: Version A.03.00 or later

Code Domain Power - Limits

Code Domain—Active Set Threshold

:CALCulate:CDPower:ASET:THReshold <numeric>

:CALCulate:CDPower:ASET:THReshold?

Set the threshold level for the active channel identification function.

Factory Preset: 0.0 dBm

Range: -100.0 to 0.0 dB

Remarks: You must be in the cdma2000, W-CDMA, or 1xEV-DO mode to use this command. Use INSTRument:SElect to set the mode.

Code Domain—Active Set Threshold Mode

:CALCulate:CDPower:ASET:THReshold:AUTO OFF|ON|0|1

:CALCulate:CDPower:ASET:THReshold:AUTO?

Turn the automatic mode On or Off, for the active channel identification function.

OFF – The active channel identification for each code channel is determined by a value set by `CALCulate:CDPower:ASET:THReshold`.

ON – The active channels are determined automatically with the internal algorithm.

Factory Preset: ON

Remarks: You must be in the cdma2000, W-CDMA, or 1xEV-DO mode to use this command. Use INSTRument:SElect to set the mode.

Code Domain—Decode Axis

:CALCulate:CDPower:AXIS[:MS] IPH|QPH

:CALCulate:CDPower:AXIS[:MS]?

Select the I phase or Q phase for the demodulation axis. (For MS only)

IPH – I phase

QPH – Q phase

Factory Preset: IPH for cdma2000

QPH for W-CDMA

Remarks: You must be in the cdma2000 or W-CDMA mode to use this command. Use INSTRument:SElect to set the mode.

CALCulate Subsystem

Code Domain—Measurement Channel Type

```
:CALCulate:CDPower:CHANnel:TYPE DATA|MAC|PIlot
```

```
:CALCulate:CDPower:CHANnel:TYPE?
```

Set one of the channel types from the following channels:

DATA – the data channel

MAC – the medium access control (MAC) channel

PIlot – the pilot channel

Factory Preset: PIlot

Remarks: You must be in the 1xEV-DO mode to use this command. Use INSTRument:SElect to set the mode.

Code Domain—Data Bit Format

```
:CALCulate:CDPower:DBITs[:FORMat] BINary | TRIState
```

```
:CALCulate:CDPower:DBITs[:FORMat]?
```

Set DBITs (Demod Bit) data representation format to Binary or Tri-state.

Factory Preset: BINary

Remarks: You must be in the W-CDMA mode to use this command. Use INSTRument:SElect to set the mode.

Code Domain—Data Bit Format Threshold

```
:CALCulate:CDPower:DBITs:TRIState:THReshold <float>
```

```
:CALCulate:CDPower:DBITs:THReshold?
```

Set DBITs (Demod Bit) threshold level for Tri-state decode.

Factory Preset: 50%

Range: 0.0 to 100.0%

Remarks: You must be in the W-CDMA mode to use this command. Use INSTRument:SElect to set the mode.

Code Domain—I/Q Combined Power

```
:CALCulate:CDPower:IQ:COMBined[:STATe]OFF|ON|0|1
```

```
:CALCulate:CDPower:IQ:COMBined[:STATe]?
```

Turn the I/Q Combined Power Bar on or off.

On- compute I/Q combined power bar.

Off- compute I/Q separated power bar.

Factory Preset: Off

Remarks: You must be in the 1xEV-DO mode to use this command. Use INSTRUMENT:SELEct to set the mode.

Code Domain—Psuedo-Random Noise Offset

:CALCulate:CDPower:PNOffset <time>

:CALCulate:CDPower:PNOffset?

Sets value for the psuedo-random noise offset. Different psuedo-random noise offsets are used for different base stations. By setting the pseudo-random noise offset to the value that your specific base station is set to, you get the correct time offset value displayed and returned back to you when you query READ:RHO?. The instrument, by default, assumes an offset of 0. So if you do not use this command you will have to manually calculate the time offset when the value is other than 0.

Factory Preset: 0 chips offset

Range: 0 to 511 (× 64 chips) 1 = 64 chip offset, 2 = 128 chips

Remarks: You must be in the cdma2000 mode to use this command. Use INSTRUMENT:SELEct to set the mode.

Code Domain—Composite Symbol Boundary

:CALCulate:CDPower:SBOundary:COMPOSITE OFF|ON|0|1

:CALCulate:CDPower:SBOundary:COMPOSITE?

Turn the composite code channel powers display function on or off. This command is effective when the [:SENSE] :CDPower:CAPTURE:TIME is set to 0.067, 1.0, or 2.0.

On - compute the code domain power based on the symbol rate identified or predefined for each spreading code.

Off - compute the code domain power based on the symbol rate set by the CALCulate:CDPower:SBOundary:SRATE command.

Factory Preset: On

Remarks: You must be in the W-CDMA mode to use this command. Use INSTRUMENT:SELEct to set the mode.

CALCulate Subsystem

Code Domain—Display Symbol Rate

:CALCulate:CDPower:SBOundary:SRATe <integer>

:CALCulate:CDPower:SBOundary:SRATe?

Set the display symbol rate to read the total power level of the combined code channels defined by the **CALCulate:CDPower:SRATe** command. This display symbol rate value is used when the

CALCulate:CDPower:SBOundary:COMPOSITE command is set to off.

Factory Preset: 15000

Range: 7500, 15000, 30000, 60000, 120000, 240000, 48000, 960000
for BTS

15000, 30000, 60000, 120000, 240000, 48000, 960000 for MS

Remarks: You must be in the W-CDMA mode to use this command. Use **INSTrument:SElect** to set the mode.

Code Domain—Walsh Code Length

:CALCulate:CDPower:SBOundary:WCODe[:LENGth] <integer>

:CALCulate:CDPower:SBOundary:WCODe[:LENGth]?

Set the display Walsh length to read the total power level of the combined code channels defined by the **CALCulate:CDPower:WCODe[:NUMBER]** command.

Factory Preset: 64 for BTS

32 for MS

Range: 4, 8, 16, 32, 64, 128 for BTS

2, 4, 8, 16, 32 for MS

Remarks: You must be in the cdma2000 mode to use this command. Use **INSTrument:SElect** to set the mode.

Code Domain—Spread Code

:CALCulate:CDPower:SPRead <integer>

:CALCulate:CDPower:SPRead?

Set a spread code.

Factory Preset: 0

Range: 0 to 511, when **CALCulate:CDPower:SRATe** = 7500

0 to 255, when **CALCulate:CDPower:SRATe** = 15000

0 to 127, when **CALCulate:CDPower:SRATe** = 30000

0 to 63, when **CALCulate:CDPower:SRATE** = 60000

0 to 31, when **CALCulate:CDPower:SRATE** = 120000

0 to 15, when **CALCulate:CDPower:SRATE** = 240000

0 to 7, when **CALCulate:CDPower:SRATE** = 480000

0 to 3, when **CALCulate:CDPower:SRATE** = 960000

Remarks: You must be in the W-CDMA mode to use this command. Use **INSTrument:SElect** to set the mode.

Code Domain—Symbol Rate

:CALCulate:CDPower:SRATE <integer>

:CALCulate:CDPower:SRATE?

Set a symbol rate.

Factory Preset: 15000 for W-CDMA

Range: 7500, 15000, 30000, 60000, 120000, 240000, 48000, 960000
for BTS of W-CDMA

15000, 30000, 60000, 120000, 240000, 48000, 960000 for MS
of W-CDMA

Remarks: You must be in the W-CDMA mode to use this command. Use **INSTrument:SElect** to set the mode.

Code Domain—Sweep Offset (Measurement Offset)

:CALCulate:CDPower:SWEep:OFFSet <integer>

:CALCulate:CDPower:SWEep:OFFSet <float> (1xEV-DO only)

:CALCulate:CDPower:SWEep:OFFSet?

1xEV-DO mode:

Set the timing offset of measurement interval in units of slot (1 slot = 1.667 ms).

The sum of **CALCulate:CDPower:SWEep:TIME** and **CALCulate:CDPower:SWEep:OFFSet** must be equal to or less than **SENSe:CDPower:CAPTure:TIME**. If the sum becomes more than the value, **CALCulate:CDPower:SWEep:OFFSet** is adjusted automatically.

cdma2000 mode:

Set the timing offset of measurement interval in units of Power Control Group (PCG; 1 PCG = 1.25 ms).

The sum of **CALCulate:CDPower:SWEep:TIME** and

CALCulate Subsystem

CALCulate:CDPower:SWEep:OFFSet must be equal to or less than **SENSe:CDPower:CAPTure:TIME**. If the sum becomes more than the value, **CALCulate:CDPower:SWEep:OFFSet** is adjusted automatically.

W-CDMA mode:

Set the timing offset of measurement interval in slots (1 slot = 625 μ s).

The sum of **CALCulate:CDPower:SWEep:TIME** and **CALCulate:CDPower:SWEep:OFFSet** must be equal to or less than **SENSe:CDPower:CAPTure:TIME** \times 15. If the sum becomes more than the value, **CALCulate:CDPower:SWEep:OFFSet** is adjusted automatically.

Factory Preset: 0

Range: 0 to **SENSe:CDPower:CAPTure:TIME** – 1 for cdma2000
0 to **SENSe:CDPower:CAPTure:TIME** – 0.5 for 1xEV-DO
0 to **SENSe:CDPower:CAPTure:TIME** \times 15 – 1 for W-CDMA

Remarks: You must be in the cdma2000, W-CDMA, or 1xEV-DO mode to use this command. Use **INSTrument:SELEct** to set the mode.

Code Domain—Sweep Time (Measurement Interval)

:CALCulate:CDPower:SWEep:TIME <integer>

:CALCulate:CDPower:SWEep:TIME <float> for (1xEV-DO only)

:CALCulate:CDPower:SWEep:TIME?

- For 1xEV-DO

Set the length of measurement interval in units of slot (1 slot = 1.667 ms).

The sum of **CALCulate:CDPower:SWEep:TIME** and **CALCulate:CDPower:SWEep:OFFSet** must be equal to or less than **SENSe:CDPower:CAPTure:TIME**. If the sum becomes more than the value, **CALCulate:CDPower:SWEep:OFFSet** is adjusted automatically.

- For cdma2000

Set the length of measurement interval in the unit of Power Control Group (PCG; 1 PCG = 1.25 ms).

The sum of **CALCulate:CDPower:SWEep:TIME** and **CALCulate:CDPower:SWEep:OFFSet** must be equal to or less than **SENSe:CDPower:CAPTure:TIME**. If the sum becomes more than the value, **CALCulate:CDPower:SWEep:OFFSet** is adjusted automatically.

- For W-CDMA

Set the length of measurement interval in slots (1 slot = 625 μ s).

The sum of **CALCulate:CDPower:SWEep:TIME** and **CALCulate:CDPower:SWEep:OFFSet** must be equal to or less than

SENSE:CDPower:CAPTURE:TIME × 15. If the sum becomes more than the value, **CALCulate:CDPower:SWEep:OFFSet** is adjusted automatically.

Factory Preset: 1

Range: 1 to **SENSE:CDPower:CAPTURE:TIME** for cdma2000
 0.5 to **SENSE:CDPower:CAPTURE:TIME** for 1xEV-DO
 1 to **SENSE:CDPower:CAPTURE:TIME** × 15 for W-CDMA

Remarks: You must be in the cdma2000, W-CDMA, or 1xEV-DO mode to use this command. Use **INSTrument:SELEct** to set the mode.

Code Domain—Time Offset for DPCH

:CALCulate:CDPower:TDPCh <integer>

:CALCulate:CDPower:TDPCh?

Set tDPCH value manually, when **:CALCulate:CDPower:TDPCh:AUTO** is OFF. This value is set at its auto number if Time Offset detection Auto mode is set to ON.

Factory Preset: 0

Range: 0 to 149

Remarks: This setting is used only when **:CALCulate:CDPower:TDPCh:AUTO** is OFF. You must be in the W-CDMA mode to use this command. Use **INSTrument:SELEct** to set the mode.

Code Domain—Time Offset Detection

:CALCulate:CDPower:TDPCh:AUTO OFF | ON | 0 | 1

:CALCulate:CDPower:TDPCh:AUTO?

Select auto or manual control of tDPCH setting. This is an advanced control and tDPCH value is normally given when the selected code is detected as an Active Channel code.

OFF - tDPCH can manually be set by **:CALCulate:CDPower:TDPCh**.

ON - tDPCH is given automatically as a result of measurement for the specified Code Channel.

Factory Preset: ON

Remarks: You must be in the W-CDMA mode to use this command. Use **INSTrument:SELEct** to set the mode.

CALCulate Subsystem

Code Domain—Computation Type

:CALCulate:CDPower:TYPE ABSolute|RELative

:CALCulate:CDPower:TYPE?

Set the code domain power computation type to either the absolute power or the relative value to the mean power.

ABSolute – code domain power is computed as the absolute power.

RELative – code domain power is computed relative to the mean power.

Factory Preset: RELative

Remarks: You must be in the cdma2000 , W-CDMA, or 1xEV_DO mode to use this command. Use INSTRument:SELEct to set the mode.

Code Domain—Data Channel Type

:CALCulate:CDPower:TYPE:DATA OPSK|QAM|QPSK

:CALCulate:CDPower:TYPE:DATA?

Select one of the following data channel types to be used for encoding:

OPSK - 8 phase shift keying (8PSK).

QAM - 16 quadrature phase shift keying (16QAM)

QPSK - Quadrature phase shift keying

Factory Preset: QPSK

Remarks: You must be in the 1xEV-DO mode to use this command. Use INSTRument:SELEct to set the mode.

Code Domain—Walsh Code Base Length

:CALCulate:CDPower:WCODE:BASE <integer>

:CALCulate:CDPower:WCODE:BASE?

Set the Walsh Code base length for BTS. (For MS, this value is always 32.)

Factory Preset: 64

Range: 64, 128

Remarks: You must be in the cdma2000 mode to use this command. Use INSTRument:SELEct to set the mode.

Code Domain—Walsh Code Length

:CALCulate:CDPower:WCODE:LENGTH <integer>

:CALCulate:CDPower:WCODE:LENGTH?

Set the Walsh Code length.

Factory Preset: 64 for BTS

32 for MS

Range: 4, 8, 16, 32, 64, 128 for BTS

2, 4, 8, 16, 32 for MS

Remarks: You must be in the cdma2000 mode to use this command. Use INSTRUMENT:SElect to set the mode.

Code Domain—Walsh Code Number

:CALCulate:CDPower:WCODE[:NUMBER] <integer>

:CALCulate:CDPower:WCODE[:NUMBER]?

Set the Walsh code number depending on the channel type.

Factory Preset: 0

Range: 0 to **CALCulate:CDPower:WCODE:LENGTH** - 1, for cdma2000

0 to 31 for Pilot,

0 to 63 for MAC,

0 to 15 for Data (1xEV-DO)

Remarks: You must be in the cdma2000 or 1xEV-DO mode to use this command. Use INSTRUMENT:SElect to set the mode.

Code Domain—Walsh Code Order

:CALCulate:CDPower:WCODE:ORDER BREVerse | (HADMrD | HADamard)

:CALCulate:CDPower:WCODE:ORDER?

Set the type of the Walsh code order to either of the following:

BREVerse (Bit Reverse) – In the order to show the higher (consolidated) spreading code as a single bundle in the CDP display

HADMrD or HADamard (Hadamard) – Regular order

Factory Preset: Hadamard (HADamard)

Remarks: You must be in the cdma2000, or 1xEV-DO mode to use this command. Use INSTRUMENT:SElect to set the mode.

Terminal Code Domain Measurement

This measurement is used to make Code Domain Power measurements on 1xEV-DO mobile stations (access terminals). To measure 1xEV-DO base stations (network access equipment) use the Code Domain Power measurement.

Terminal Code Domain - Active Set Threshold

:CALCulate:TCDPower:ASET:THReshold <numeric>

:CALCulate:TCDPower:ASET:THReshold?

Set the threshold level for the active channel identification function.

Factory Preset: 0.0 dBm

Range: -100.0 to 0.0 dB

Remarks: You must be in the 1xEV-DO mode to use this command. Use INSTRument:SElect to set the mode.

Terminal Code Domain - Active Set Threshold Mode

:CALCulate:TCDPower:ASET:THReshold:AUTO OFF|ON|0|1

:CALCulate:TCDPower:ASET:THReshold:AUTO?

Turn the automatic mode On or Off, for the active channel identification function.

OFF – The active channel identification for each code channel is determined by a value set by CALCulate:RHO:ASET:THReshold.

ON – The active channels are determined automatically with the internal algorithm.

Factory Preset: ON

Remarks: You must be in the 1xEV-DO mode to use this command. Use INSTRument:SElect to set the mode.

Terminal Code Domain - I/Q Branch (Decode Axis)

:CALCulate:TCDPower:AXIS IPH|QPH

:CALCulate:TCDPower:AXIS?

Select the I phase or Q phase for the demodulation axis.

IPH – I phase

QPH – Q phase

Factory Preset: IPH

Remarks: You must be in the 1xEV-DO mode to use this command. Use

INSTRument:SElect to set the mode.

Terminal Code Domain - Sweep Offset (Measurement Offset)

:CALCulate:TCDPower:SWEep:OFFSet <float>

:CALCulate:TCDPower:SWEep:OFFSet?

Set the timing offset of measurement start in slots to be used (1 slot = 1.667 ms).

Factory Preset: 0

Range: 0 to [:SENSe]:TCDPower:CAPTure:TIME – 0.5

Remarks: You must be in the 1xEV-DO mode to use this command. Use INSTRument:SElect to set the mode.

This number is coupled with **CALCulate:TCDPower:SWEep:TIME**. Since the total acquired data is [:SENSe]:TCDPower:CAPTure:TIME slots, if the sum of **CALCulate:TCDPower:SWEep:OFFSet** plus [:SENSe]:TCDPower:SWEep:TIME becomes more than the value of [:SENSe]:TCDPower:CAPTure:TIME, then **CALCulate:TCDPower:SWEep:TIME** is adjusted automatically.

Terminal Code Domain - Sweep Time (Measurement Interval)

:CALCulate:TCDPower:SWEep:TIME <float>

:CALCulate:TCDPower:SWEep:TIME?

Set the length of measurement interval in slots to be used (1 slot = 1.667 ms).

Factory Preset: 1

Range: 0.5 to **SENSe:TCDPower:CAPTure:TIME**

Remarks: You must be in the 1xEV-DO mode to use this command. Use INSTRument:SElect to set the mode.

This number is coupled with **CALCulate:TCDPower:SWEep:OFFSet**. Since the total acquired data is [:SENSe]:TCDPower:CAPTure:TIME slots, if the sum of **CALCulate:TCDPower:SWEep:OFFSet** plus [:SENSe]:TCDPower:SWEep:TIME becomes more than the value of [:SENSe]:TCDPower:CAPTure:TIME, then **CALCulate:TCDPower:SWEep:OFFSet** is adjusted automatically.

Terminal Code Domain - Measurement Type

:CALCulate:TCDPower:TYPE ABSolute|RELative

:CALCulate:TCDPower:TYPE?

Set the code domain power computation type to either the absolute power or the relative value to the mean power.

ABSolute – code domain power is computed as the absolute power.

CALCulate Subsystem

RELative – code domain power is computed relative to the mean power.

Factory Preset: RELative

Remarks: You must be in the 1xEV_DO mode to use this command. Use INSTRument:SElect to set the mode.

Terminal Code Domain - Walsh Code Length

:CALCulate:TCDPower:WCODE:LENGTH <integer>

:CALCulate:TCDPower:WCODE:LENGTH?

Set the Walsh Code length.

Factory Preset: 16

Range: 4, 8, 16

Remarks: You must be in the 1xEV-DO mode to use this command. Use INSTRument:SElect to set the mode.

Terminal Code Domain - Walsh Code Number

:CALCulate:TCDPower:WCODE[:NUMBER] <integer>

:CALCulate:TCDPower:WCODE[:NUMBER]?

Set the Walsh code number depending on the channel type.

Factory Preset: 0

Range: 0 to **CALCulate:TCDPower:WCODE:LENGTH** – 1

Remarks: You must be in the 1xEV-DO mode to use this command. Use INSTRument:SElect to set the mode.

Terminal Code Domain - Walsh Code Order

:CALCulate:TCDPower:WCODE:ORDER BREVerse|HADMrd

:CALCulate:TCDPower:WCODE:ORDER?

Set the type of the Walsh code order to either of the following:

BREVerse (Bit Reverse) – In the order to show the higher (consolidated) spreading code as a single bundle in the CDP display

HADMrd (Hadamard) – Regular order

Factory Preset: Hadamard (HADMrd)

Remarks: You must be in the 1xEV-DO mode to use this command. Use INSTRument:SElect to set the mode.

Test Current Results Against all Limits

:CALCulate:CLIMits:FAIL?

Queries the status of the current measurement limit testing. It returns a 0 if the measured results pass when compared with the current limits. It returns a 1 if the measured results fail any limit tests.

Data Query

:CALCulate:DATA[n]?

Returns the designated measurement data for the currently selected measurement and sub-opcode.

n = any valid sub-opcode for the current measurement. See the “[MEASure Group of Commands](#)” on page 193 for information on the data that can be returned for each measurement.

For sub-opcodes that return trace data use the
:CALCulate:DATA[n]:COMPRESS? command below.

Calculate/Compress Trace Data Query

:CALCulate:DATA<n>:COMPRESS?

**BLOCK|CFIT|MAXimum|MEAN|MINimum|RMS|SAMPLE|SDEVIation
[,<soffset>[,<length>[,<roffset>[,<rlimit>]]]]**

Returns compressed data for the specified trace data. The data is returned in the same units as the original trace and only works with the currently selected measurement. The command is used with a sub-opcode <n> since measurements usually return several types of trace data. See the following table for the sub-opcodes for the trace data names that are available in each measurement. For sub-opcodes that return scalar data use the :CALCulate:DATA[n]? command above.

This command is used to compress or decimate a long trace to extract and return only the desired data. A typical example would be to acquire N frames of GSM data and return the mean power of the first burst in each frame. The command can also be used to identify the best curve fit for the data.

BLOCK or block data - returns all the data points from the region of the trace data that you specify. For example, it could be used to return the data points of an input signal over several timeslots, excluding the portions of the trace data that you do not want.

CFIT or curve fit - applies curve fitting routines to the data. <soffset> and <length> are required to define the data that you want. <roffset> is an optional

CALCulate Subsystem

parameter for the desired order of the curve equation. The query will return the following values: the x-offset (in seconds) and the curve coefficients ((order + 1) values).

MAX, MEAN, MIN, RMS, SAMP, and SDEV return one data value for each specified region (or <length>) of trace data, for as many regions as possible until you run out of trace data (using <roffset> to specify regions). Or they return the number regions you specify (using <rlimit>) ignoring any data beyond that.

MAXimum - returns the maximum data point for the specified region(s) of trace data. For I/Q trace data, the maximum magnitude of the I/Q pairs is returned.

MEAN - returns the arithmetic mean of the data point values for the specified region(s) of trace data. See [“Mean Value of Data Points for Specified Region\(s\)” on page 91](#). For I/Q trace data, the mean of the magnitudes of the I/Q pairs is returned. See [“Mean Value of I/Q Data Pairs for Specified Region\(s\)” on page 91](#).

Note: If the original trace data is in dB, this function returns the arithmetic mean of those log values, not log of the mean power, which is a more useful value.

Equation 0-1 Mean Value of Data Points for Specified Region(s)

$$\text{MEAN} = \frac{1}{n} \sum_{X_i \in \text{region}(s)} X_i$$

where X_i is a data point value, and n is the number of data points in the specified region(s).

Equation 0-2 Mean Value of I/Q Data Pairs for Specified Region(s)

$$\text{MEAN} = \frac{1}{n} \sum_{X_i \in \text{region}(s)} |X_i|$$

where $|X_i|$ is the magnitude of an I/Q pair, and n is the number of I/Q pairs in the specified region(s).

MINimum - returns the minimum data point for the specified region(s) of trace data. For I/Q trace data, the minimum magnitude of the I/Q pairs is returned.

RMS - returns the arithmetic rms of the data point values for the specified region(s) of trace data. See [“RMS Value of Data Points for Specified Region\(s\)”](#) on page 91.

For I/Q trace data, the rms of the magnitudes of the I/Q pairs is returned. See [“RMS Value of I/Q Data Pairs for Specified Region\(s\)”](#) on page 92.

Note: This function is very useful for I/Q trace data. However, if the original trace data is in dB, this function returns the rms of the log values which is not usually needed.

Equation 0-3 RMS Value of Data Points for Specified Region(s)

$$\text{RMS} = \sqrt{\frac{1}{n} \sum_{X_i \in \text{region}(s)} X_i^2}$$

where X_i is a data point value, and n is the number of data points in the specified region(s).

Equation 0-4 RMS Value of I/Q Data Pairs for Specified Region(s)

$$\text{RMS} = \sqrt{\frac{1}{n} \sum_{X_i \in \text{region}(s)} X_i X_i^*}$$

where X_i is the complex value representation of an I/Q pair, X_i^* its conjugate complex number, and n is the number of I/Q pairs in the specified region(s).

Once you have the rms value for a region of I/Q trace data, you may want to calculate the mean power. You must convert this rms I/Q value (peak volts) to power in dB.

$$10 \times \log[10 \times (\text{rms value})^2]$$

SAMPLE - returns the first data value for the specified region(s) of trace data. For I/Q trace data, the first I/Q pair is returned.

SDEViation - returns the arithmetic standard deviation for the data point values for the specified region(s) of trace data. See “[Standard Deviation of Data Point Values for Specified Region\(s\)](#)” on page 92.

For I/Q trace data, the standard deviation of the magnitudes of the I/Q pairs is returned. See “[Standard Deviation of I/Q Data Pair Values for Specified Region\(s\)](#)” on page 92.

Equation 0-5 Standard Deviation of Data Point Values for Specified Region(s)

$$\text{SDEV} = \sqrt{\frac{1}{n} \sum_{X_i \in \text{region}(s)} (X_i - \bar{X})^2}$$

where X_i is a data point value, \bar{X} is the arithmetic mean of the data point values for the specified region(s), and n is the number of data points in the specified region(s).

Equation 0-6 Standard Deviation of I/Q Data Pair Values for Specified Region(s)

$$\text{SDEV} = \sqrt{\frac{1}{n} \sum_{X_i \in \text{region}(s)} (|X_i| - \bar{X})^2}$$

where $|X_i|$ is the magnitude of an I/Q pair, \bar{X} is the mean of the magnitudes for the specified region(s), and n is the number of data points in the specified region(s).

Figure 0-1 Sample Trace Data - Constant Envelope

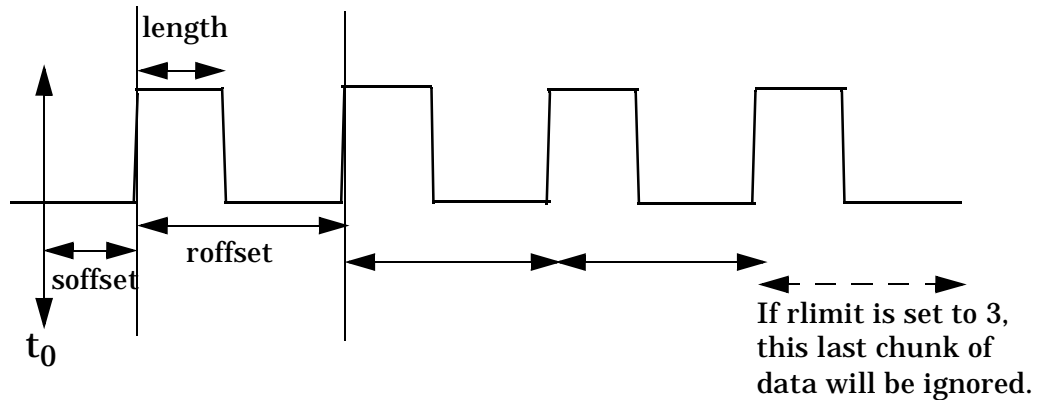
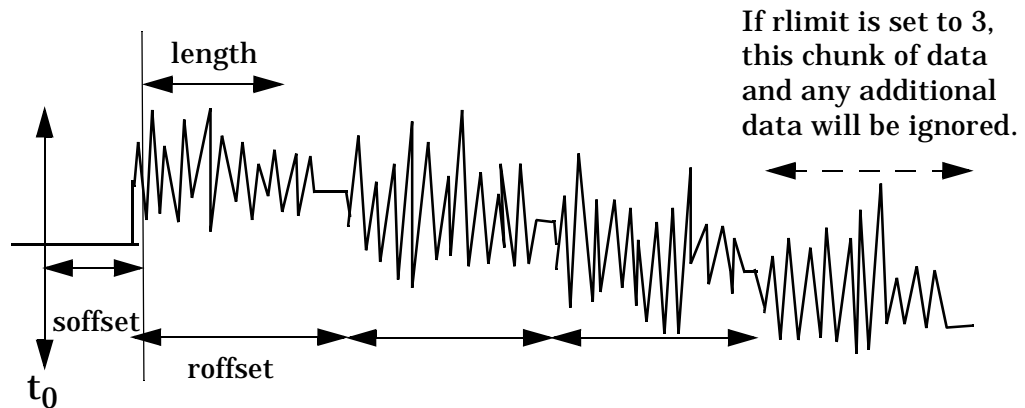

Figure 0-2 Sample Trace Data - Not Constant Envelope



<soffset> - start offset is an optional real number (in seconds). It specifies the amount of data at the beginning of the trace that will be ignored before the decimation process starts. It is the time from the start of the trace to the point where you want to start using the data. The default value is zero.

<length> - is an optional real number (in seconds). It defines how much data will be compressed into one value. This parameter has a default value equal to the current trace length.

<roffset> - repeat offset is an optional real number (in seconds). It defines the beginning of the next field of trace elements to be compressed. This is relative to the beginning of the previous field. This parameter has a default value equal to the <length> variable.

<rlimit> - repeat limit is an optional integer. It specifies the number of data items that you want returned. It will ignore any additional items beyond that number. You can use the Start offset and the Repeat limit to pick out exactly what part of the data you want to use. The default value is all the data.

Example: To query the mean power of a set of GSM bursts:

CALCulate Subsystem

1. Set the waveform measurement sweep time to acquire at least one burst.
2. Set the triggers such that acquisition happens at a known position relative to a burst.
3. Then query the mean burst levels using,
CALC:DATA2:COMP? MEAN,24e-6,526e-6 (These parameter values correspond to GSM signals, where 526e-6 is the length of the burst in the slot and you just want 1 burst.)

NOTE

There is a more detailed example in the “Improving the Speed of Your Measurements” section in the E4406A *Programmer’s Guide*. There is also a sample program in the Programming Fundamentals chapter of that book, and a copy of it is on the documentation CD-ROM.

Remarks: The optional parameters must be entered in the specified order. For example, if you want to specify <length>, you must also specify <soffset>.

This command uses the data in the format specified by FORMat:DATA, returning either binary or ASCII data.

History: Added in revision A.03.00
 Changed in revision A.05.00

Measurement	Available Traces	Markers Available?
ACP - adjacent channel power (Basic, cdmaOne, cdma2000, W-CDMA, iDEN, NADC, PDC modes)	no traces (n=0) ^a for I/Q points	no markers
BER - bit error rate (iDEN mode)	no traces (n=0) ^a for I/Q data	no markers
CDPower - code domain power (cdmaOne mode)	POWer (n=2) ^a TIMing (n=3) ^a PHASe (n=4) ^a (n=0) ^a for I/Q points	yes

Measurement	Available Traces	Markers Available?
CDPower - code domain power (cdma2000, W-CDMA modes)	CDPower ($n=2$) ^a EVM ($n=5$) ^a MERRor ($n=6$) ^a PERRor ($n=7$) ^a SPOWer ($n=9$) ^a CPOWer ($n=10$) ^a ($n=0$) ^a for I/Q points	yes
CHPower - channel power (Basic, cdmaOne, cdma2000, W-CDMA modes)	SPECTrum ($n=2$) ^a ($n=0$) ^a for I/Q points	no markers
CSPur - spurs close (cdmaOne mode)	SPECTrum ($n=2$) ^a ULIMit ($n=3$) ^a ($n=0$) ^a for I/Q points	yes
EEVM - EDGE error vector magnitude (EDGE mode)	EVMerror ($n=2$) ^a MERRor ($n=3$) ^a PERRor ($n=4$) ^a ($n=0$) ^a for I/Q points	yes
EORFspectr - EDGE output RF spectrum (EDGE mode)	RFEMod ($n=2$) ^a RFESwitching ($n=3$) ^a SPEMod ($n=4$) ^a LIMMod ($n=5$) ^a ($n=0$) ^a for I/Q points	yes, only for a single offset yes, only for multiple offsets
EPVTime - EDGE power versus time (EDGE mode)	RFENvelope ($n=2$) ^a UMASk ($n=3$) ^a LMASk ($n=4$) ^a ($n=0$) ^a for I/Q points	yes
ETSPur - EDGE transmit band spurs (EDGE mode)	SPECTrum ($n=2$) ^a ULIMit ($n=3$) ^a ($n=0$) ^a for I/Q points	yes

CALCulate Subsystem

Measurement	Available Traces	Markers Available?
EVM - error vector magnitude (NADC, PDC modes)	EVM ($n=2$) ^a MERRor ($n=3$) ^a PERRor ($n=4$) ^a ($n=0$) ^a for I/Q points	yes
EVMQpsk - QPSK error vector magnitude (cdma2000, W-CDMA modes)	EVM ($n=2$) ^a MERRor ($n=3$) ^a PERRor ($n=4$) ^a ($n=0$) ^a for I/Q points	yes
IM - intermodulation (cdma2000, W-CDMA modes)	SPECTrum ($n=2$) ^a ($n=0$) ^a for I/Q points	yes
MCPower - multi-carrier power (W-CDMA mode)	no traces ($n=0$) ^a for I/Q points	no markers
OBW - occupied bandwidth (cdmaOne, cdma2000, iDEN, PDC, W-CDMA modes)	no traces ($n=0$) ^a for I/Q points	no markers
ORFSpectrum - output RF spectrum (GSM, EDGE mode)	RFEMod ($n=2$) ^a RFESwitching ($n=3$) ^a SPEMod ($n=4$) ^a LIMMod ($n=5$) ^a ($n=0$) ^a for I/Q points	yes, only for a single offset yes, only for multiple offsets
PFERror - phase and frequency error (GSM, EDGE mode)	PERRor ($n=2$) ^a PFERror ($n=3$) ^a RFENvelope ($n=4$) ^a ($n=0$) ^a for I/Q points	yes
PSTatistic - power statistics CCDF (Basic, cdma2000, W-CDMA modes)	MEASured ($n=2$) ^a GAUSian ($n=3$) ^a REFerence ($n=4$) ^a ($n=0$) ^a for I/Q points	yes

Measurement	Available Traces	Markers Available?
PVTime - power versus time (GSM, EDGE, Service modes)	RFENvelope ($n=2$) ^a UMASk ($n=3$) ^a LMASk ($n=4$) ^a ($n=0$) ^a for I/Q points	yes
RHO - modulation quality (cdmaOne, cdma2000, W-CDMA mode)	($n=0$) ^a for I/Q points EVM ($n=2$) ^a MERRor ($n=3$) ^a PERRor ($n=4$) ^a ($n=0$) ^a for I/Q points	yes
SEMask - spectrum emissions mask (cdma2000, W-CDMA mode)	SPECTrum ($n=2$) ^a ($n=0$) ^a for I/Q points	yes
TSPur - transmit band spurs (GSM, EDGE mode)	SPECTrum ($n=2$) ^a ULIMit ($n=3$) ^a ($n=0$) ^a for I/Q points	yes
TXPower - transmit power (GSM, EDGE mode)	RFENvelope ($n=2$) ^a IQ ($n=8$) ^a ($n=0$) ^a for I/Q points	yes
SPECTrum - (frequency domain) (all modes)	RFENvelope ($n=2$) ^a for Service mode IQ ($n=3$) ^a SPECTrum ($n=4$) ^a ASPECTrum ($n=7$) ^a ($n=0$) ^a for I/Q points	yes
WAVEform - (time domain) (all modes)	RFENvelope ($n=2$) ^a (also for Signal Envelope trace) IQ ($n=5$) ^a ($n=0$) ^a for I/Q points	yes

CALCulate Subsystem

- a. The n number indicates the sub-opcode that corresponds to this trace. Detailed descriptions of the trace data can be found in the MEASure subsystem documentation by looking up the sub-opcode for the appropriate measurement.

Calculate Peaks of Trace Data

:CALCulate:DATA<n>:PEAKs?
<threshold>,<excursion>[,AMPLitude | FREQuency | TIME]

Returns a list of peaks for the designated trace data *n* for the currently selected measurement. The peaks must meet the requirements of the peak threshold and excursion values.

The command can only be used with specific *<n>* (sub-opcode) values, for measurement results that are trace, or scalar, data. See the table above for the appropriate sub-opcodes. Both real and complex traces can be searched, but complex traces are converted to magnitude in dBm. Sub-opcode *n=0*, is the raw trace data which cannot be searched for peaks. Sub-opcode *n=1*, is the scaler data which also cannot be searched for peaks.

Threshold - is the level below which trace data peaks are ignored

Excursion - To be defined as a peak, the signal must rise above the threshold by a minimum amplitude change (excursion). Excursion is measured from the lowest point above the threshold (of the rising edge of the peak), to the highest signal point that begins the falling edge. If a signal valley is higher than the threshold, then the excursion is referenced to that valley, and a peak is only defined if the signal following that valley exceeds the excursion.

Amplitude - lists the peaks in order of descending amplitude, so the highest peak is listed first. This is the default peak order listing if the optional parameter is not specified.

Frequency - lists the peaks in order of occurrence, left to right across the x-axis

Time - lists the peaks in order of occurrence, left to right across the x-axis

Example: Select the spectrum measurement.

Use **CALC:DATA4:PEAK? -40,10,FREQ** to identify the peaks above -40 dBm, with excursions of at least 10 dB, in order of increasing frequency.

Query Results: Returns a list of floating-point numbers. The first value in the list is the number of peak points that follow. A peak point consists of two values: a peak amplitude followed by the its corresponding frequency (or time).

If no peaks are found the peak list will consist of only the number of peaks, (0).

The peak list is limited to 100 peaks. Peaks in excess of 100 are ignored.

Remarks: This command uses the data setting specified by the **FORMat:DATA** command and can return real 32-bit, real 64-bit, or ASCII data. The default data format is ASCII.

History: For E4406A:
 Added in revision A.03.00 and later

CALCulate Subsystem

EDGE TX Band Spur Calculate Commands

EDGE Transmit Band Spurs—Type of Limit Testing

:CALCulate:ETSPur:LIMit:TEST ABSolute|RELative

:CALCulate:ETSPur:LIMit:TEST?

Select the limit testing to be done using either absolute (dBm) or relative power (dB) limits.

Factory Preset: Absolute

Remarks: You must be in the EDGE (w/GSM) mode to use this command.
Use INSTRument:SElect to set the mode.

History: For E4406A:
Version A.05.00 or later

Front Panel

Access: **Meas Setup, More, Limit**

EDGE Transmit Band Spurs—Define Limits

:CALCulate:ETSPur:LIMit[:UPPer][[:DATA] <power>

:CALCulate:ETSPur:LIMit[:UPPer][[:DATA]?

Set the value for the test limit. This command does not accept units. Use CALCulate:ETSPur:LIMit:TEST to select the units dBm (absolute) or dB (relative).

Factory Preset: -36

Range: -200 to 100

Remarks: You must be in the EDGE (w/GSM) mode to use this command.
Use INSTRument:SElect to set the mode.

History: For E4406A:
Version A.05.00 or later

Front Panel

Access: **Meas Setup, More, Limit**

CALCulate Subsystem

EVM - Limits

Error Vector Magnitude—First 10 Symbols EVM Limit

:CALCulate:EVM:LIMit:F10 <percent>

:CALCulate:EVM:LIMit:F10?

Set the first 10 symbols EVM limit in percent. This functionality is only for mobile testing.

Factory Preset: 25.0%

Range: 0 to 50%

Remarks: You must be in the NADC mode to use this command. Use INSTRument:SElect to set the mode.

History: For E4406A:
Version A.02.00 or later

Error Vector Magnitude—I/Q Origin Offset Error Limit

:CALCulate:EVM:LIMit:IQOOffset <dB>

:CALCulate:EVM:LIMit:IQOOffset?

Set the I/Q origin offset error limit in dB.

Factory Preset: -20 dB

Range: -100 dB to 0 dB

Remarks: You must be in the NADC or PDC mode to use this command. Use INSTRument:SElect to set the mode.

History: Version A.02.00 or later

Error Vector Magnitude—Peak EVM Limit

:CALCulate:EVM:LIMit:PEAK <percent>

:CALCulate:EVM:LIMit:PEAK?

Set the peak EVM limit in percent.

Factory Preset: 40.0%

Range: 0 to 50%

Remarks: You must be in the NADC or PDC mode to use this command. Use INSTRument:SElect to set the mode.

History: For E4406A:
Version A.02.00 or later

Error Vector Magnitude—RMS EVM Limit**:CALCulate:EVM:LIMit:RMS <percent>****:CALCulate:EVM:LIMit:RMS?**

Set the RMS EVM limit in percent.

Factory Preset: 12.5%

Range: 0 to 50%

Remarks: You must be in the NADC or PDC mode to use this command.
Use INSTRument:SElect to set the mode.History: For E4406A:
Version A.02.00 or later**Error Vector Magnitude—Limit Test****:CALCulate:EVM:LIMit[:TEST] OFF|ON|0|1****:CALCulate:EVM:LIMit[:TEST]?**

Turn limit test on or off.

Factory Preset: On

Remarks: You must be in the NADC or PDC mode to use this command.
Use INSTRument:SElect to set the mode.History: For E4406A:
Version A.02.00 or later**Error Vector Magnitude—Time to Sync Word****:CALCulate:EVM:TTSWord?**

Query returns the time between the trigger and the start of the first sync word.

Default Unit: Seconds

Remarks: You must be in the NADC or PDC mode to use this command.
Use INSTRument:SElect to set the mode.History: For E4406A:
Version A.03.00 or later

CALCulate Subsystem

QPSK EVM - Limits

QPSK Error Vector Magnitude—IQ Offset Include

:CALCulate:EVMQpsk:IQOffset:INCLude OFF|ON|0|1

:CALCulate:EVMQpsk:IQOffset:INCLude?

Select I/Q origin offset error is included into EVM calculation or not.

ON - I/Q origin offset is included into EVM calculation.

OFF - I/Q origin offset is excluded from EVM calculation.

Factory Preset: ON

Remarks: You must be in the W-CDMA mode to use this command. Use INSTRUMENT:SElect to set the mode.

QPSK Error Vector Magnitude—Frequency Error Limit

:CALCulate:EVMQpsk:LIMit:FERRor <float>

:CALCulate:EVMQpsk:LIMit:FERRor?

Set the Frequency Error Limit in Hz.

Factory Preset: 200.0 Hz

Range: 0.0 to 300.0 kHz

Remarks: You must be in the W-CDMA mode to use this command. Use INSTRUMENT:SElect to set the mode.

QPSK Error Vector Magnitude—RMS EVM Limit

:CALCulate:EVMQpsk:LIMit:RMS <float>

:CALCulate:EVMQpsk:LIMit:RMS?

Set the I/Q origin offset error limit in dB.

Factory Preset: 17.5 %

Range: 0.0 to 100.0 %

Remarks: You must be in the W-CDMA mode to use this command. Use INSTRUMENT:SElect to set the mode.

CALCulate:MARKers Subsystem

Markers can be put on your displayed measurement data to supply information about specific points on the data. Some of the things that markers can be used to measure include: precise frequency at a point, minimum or maximum amplitude, and the difference in amplitude or frequency between two points.

When using the marker commands you must specify the measurement in the SCPI command. We recommend that you use the marker commands only on the current measurement. Many marker commands will return invalid results, when used on a measurement that is not current. (This is true for commands that do more than simply setting or querying an instrument parameter.) No error is reported for these invalid results.

You must make sure that the measurement is completed before trying to query the marker value. Using the MEASure or READ command, before the marker command, forces the measurement to complete before allowing the next command to be executed.

Each measurement has its own instrument state for marker parameters. Therefore, if you exit the measurement, the marker settings in each measurement are saved and are then recalled when you change back to that measurement.

Basic Mode - <measurement> key words

- ACPr - no markers (E4406A only)
- CHPower - no markers (E4406A only)
- PStatistic - markers available (E4406A only)
- SPECTrum - markers available
- WAVEform - markers available

Service Mode - <measurement> key words

- PVTime - no markers
- SPECTrum - markers available
- WAVEform - markers available

1xEV-DO Mode - <measurement> key words

- CDPower - markers available
- CHPower - no markers
- EVMQpsk - markers available
- IM - markers available
- OBW - no markers
- PStatistic - markers available
- PVTime - markers available
- RHO - markers available
- SEMask - markers available
- SPECTrum - markers available
- WAVEform - markers available

CALCulate Subsystem

cdmaOne Mode - <measurement> key words

- ACPr - no markers
- CHPower - no markers
- CDPower - markers available
- CSPur - markers available
- RHO - markers available
- SPECTrum - markers available
- WAVeform - markers available

cdma2000 Mode - <measurement> key words

- ACP - no markers
- CDPower - markers available
- CHPower - no markers
- EVMQpsk - markers available
- IM - markers available
- OBW - no markers
- PSTatistic - markers available
- RHO - markers available
- SEMask - markers available
- SPECTrum - markers available
- WAVeform - markers available

GSM (with EDGE) Mode - <measurement> key words

- EEVM - markers available
- EORFspectr - markers available
- EPVTime - no markers
- ETSPur - markers available
- ORFSpectrum - markers available
- PFERror - markers available
- PVTime - no markers
- SPECTrum - markers available
- TSPur - markers available
- TXPower - no markers
- WAVeform - markers available

GSM Mode - <measurement> key words

- ORFSpectrum - markers available
- PFERror - markers available
- PVTime - no markers
- SPECTrum - markers available
- TSPur - markers available
- TXPower - no markers
- WAVeform - markers available

iDEN Mode - <measurement> key words

- ACP - no markers

- BER - no markers
- OBW - no markers
- SPECTrum - markers available
- WAVEform - markers available

NADC Mode - <measurement> key words

- ACP - no markers
- EVM - markers available
- SPECTrum - markers available
- WAVEform - markers available

PDC Mode - <measurement> key words

- ACP - no markers
- EVM - markers available
- OBW - no markers
- SPECTrum - markers available
- WAVEform - markers available

W-CDMA Mode - <measurement> key words

- ACP - no markers
- CDPower - markers available
- CHPower - no markers
- EVMQpsk - markers available
- IM - markers available
- MCPower - no markers
- OBW - no markers
- PSTatistic - markers available
- PCONtrol - markers available
- PSTatistic - markers available
- PVTmask - markers available
- SEMask - markers available
- SPECTrum - markers available
- WAVEform - markers available

Example:

Suppose you are using the Spectrum measurement in your measurement personality. To position marker 2 at the maximum peak value of the trace that marker 2 is currently on, the command is:

:CALCulate:SPECTrum:MARKer2:MAXimum

You must make sure that the measurement is completed before trying to query the marker value. Use the MEASure or READ command before using the marker command. This forces the measurement to complete before allowing the next command to be executed.

CALCulate Subsystem

Markers All Off on All Traces

:CALCulate:<measurement>:MARKer:AOff

Turns off all markers on all the traces in the specified measurement.

Example: **CALC:SPEC:MARK:AOff**

Remarks: The keyword for the current measurement must be specified in the command. (Some examples include: SPECTrum, WAVEform)

Front Panel

Access: **Marker, More, Marker All Off**

Marker Function Result

:CALCulate:<measurement>:MARKer[1]|2|3|4:FUNCTION:RESult?

Queries the result of the currently active marker function. The measurement must be completed before querying the marker. A particular measurement may not have all the types of markers available.

The marker must have already been assigned to a trace. Use

:CALCulate:<measurement>:MARKer[1]|2|3|4:TRACe to assign a marker to a particular trace.

Example: **CALC:SPEC:MARK:FUNC:RES?**

Remarks: The keyword for the current measurement must be specified in the command. (Some examples include: SPECTrum, WAVEform)

Front Panel

Access: **Marker, Marker Function**

Marker Peak (Maximum) Search

:CALCulate:<measurement>:MARKer[1]|2|3|4:MAXimum

Places the selected marker on the highest point on the trace that is assigned to that particular marker number.

The marker must have already been assigned to a trace. Use

:CALCulate:<measurement>:MARKer[1]|2|3|4:TRACe to assign a marker to a particular trace.

Example: **CALC:SPEC:MARK1:MAX**

Remarks: The keyword for the current measurement must be specified in the command. (Some examples include: SPECTrum, WAVEform)

Front Panel

Access: **Search**

Marker Peak (Minimum) Search

:CALCulate:<measurement>:MARKer [1] | 2 | 3 | 4 :MINimum

Places the selected marker on the lowest point on the trace that is assigned to that particular marker number.

The marker must have already been assigned to a trace. Use

:CALCulate:<measurement>:MARKer [1] | 2 | 3 | 4 :TRACe to assign a marker to a particular trace.

Example: **CALC:SPEC:MARK2 MIN**

Remarks: The keyword for the current measurement must be specified in the command. (Some examples include: SPECTrum, WAVeform)

Marker Mode

E4406A (all modes):

**:CALCulate:<measurement>:MARKer [1] | 2 | 3 | 4 :MODE
POSition|DELTA**

:CALCulate:<measurement>:MARKer [1] | 2 | 3 | 4 :MODE?

E4406A/PSA: Selects the type of marker to be a normal position-type marker or a delta marker. A specific measurement may not have both types of markers. For example, several measurements only have position markers

The marker must have already been assigned to a trace. Use

:CALCulate:<measurement>:MARKer [1] | 2 | 3 | 4 :TRACe to assign a marker to a particular trace.

Example: **CALC:SPEC:MARK:MODE DELTA**

Remarks: For the delta mode only markers 1 and 2 are valid.

The keyword for the current measurement must be specified in the command. (Some examples include: SPECTrum, WAVeform)

Front Panel

Access: **Marker, Marker [Delta]**

Marker On/Off

:CALCulate:<measurement>:MARKer [1] | 2 | 3 | 4 [:STATe] OFF|ON|0|1

:CALCulate:<measurement>:MARKer [1] | 2 | 3 | 4 [:STATe]?

Turns the selected marker on or off.

The marker must have already been assigned to a trace. Use

:CALCulate:<measurement>:MARKer [1] | 2 | 3 | 4 :TRACe to assign a marker to a particular trace.

CALCulate Subsystem

Example: **CALC:SPEC:MARK2: on**

Remarks: The keyword for the current measurement must be specified in the command. (Some examples include: SPECTrum, AREFERENCE, WAVEform)

The WAVEform measurement only has two markers available.

Front Panel
Access: **Marker, Select** then **Marker Normal** or **Marker On Off**

Marker to Trace

:CALCulate:<measurement>:MARKer[1]|2|3|4:TRACe <trace_name>
:CALCulate:<measurement>:MARKer[1]|2|3|4:TRACe?

Assigns the specified marker to the designated trace. Not all types of measurement data can have markers assigned to them.

Example: With the WAVEform measurement selected, a valid command is **CALC:SPEC:MARK2:TRACE rfenvelope**.

Range: The names of valid traces are dependent upon the selected measurement. See the following table for the available trace names. The trace name assignment is independent of the marker number.

Remarks: The keyword for the current measurement must be specified in the command. (Some examples include: SPECTrum, WAVEform)

Front Panel
Access: **Marker, Marker Trace**

Measurement	Available Traces	Markers Available?
ACP - adjacent channel power (Basic, cdmaOne, cdma2000, W-CDMA, iDEN (E4406A only), NADC, PDC modes)	no traces $(n=0)^a$ for I/Q points	no markers
BER - bit error rate (iDEN mode, E4406A only)	no traces $(n=0)^a$ for I/Q data	no markers
CDPower - code domain power (cdmaOne mode)	POWer $(n=2)^a$ TIMing $(n=3)^a$ PHASe $(n=4)^a$ $(n=0)^a$ for I/Q points	yes

Measurement	Available Traces	Markers Available?
CDPower - code domain power (cdma2000, W-CDMA, 1xEV-DO modes)	CDPower ($n=2$) ^a EVM ($n=5$) ^a MERRor ($n=6$) ^a PERRor ($n=7$) ^a SPOWer ($n=9$) ^a CPOWer ($n=10$) ^a ($n=0$) ^a for I/Q points	yes
CHPower - channel power (Basic, cdmaOne, cdma2000, W-CDMA, 1xEV-DO modes)	SPECTrum ($n=2$) ^a ($n=0$) ^a for I/Q points	no markers
CSPur - spurs close (cdmaOne mode)	SPECTrum ($n=2$) ^a ULIMit ($n=3$) ^a ($n=0$) ^a for I/Q points	yes
EEVM - EDGE error vector magnitude (EDGE mode)	EVMerror ($n=2$) ^a MERRor ($n=3$) ^a PERRor ($n=4$) ^a ($n=0$) ^a for I/Q points	yes
EORFspectr - EDGE output RF spectrum (EDGE mode)	RFEMod ($n=2$) ^a RFESwitching ($n=3$) ^a SPEMod ($n=4$) ^a LIMMod ($n=5$) ^a ($n=0$) ^a for I/Q points	yes, only for a single offset yes, only for multiple offsets
EPVTime - EDGE power versus time (EDGE mode)	RFENvelope ($n=2$) ^a UMASk ($n=3$) ^a LMASk ($n=4$) ^a ($n=0$) ^a for I/Q points	yes
ETSPur - EDGE transmit band spurs (EDGE mode)	SPECTrum ($n=2$) ^a ULIMit ($n=3$) ^a ($n=0$) ^a for I/Q points	yes

CALCulate Subsystem

Measurement	Available Traces	Markers Available?
EVM - error vector magnitude (NADC, PDC modes)	EVM ($n=2$) ^a MERRor ($n=3$) ^a PERRor ($n=4$) ^a ($n=0$) ^a for I/Q points	yes
EVMQpsk - QPSK error vector magnitude (cdma2000, W-CDMA, 1xEV-DO modes)	EVM ($n=2$) ^a MERRor ($n=3$) ^a PERRor ($n=4$) ^a ($n=0$) ^a for I/Q points	yes
IM - intermodulation (cdma2000, W-CDMA, 1xEV-DO modes)	SPECTrum ($n=2$) ^a ($n=0$) ^a for I/Q points	yes
MCPower - multi-carrier power (W-CDMA mode)	no traces ($n=0$) ^a for I/Q points	no markers
OBW - occupied bandwidth (cdmaOne, cdma2000, iDEN (E4406A only), PDC, W-CDMA, 1xEV-DO modes)	no traces ($n=0$) ^a for I/Q points	no markers
ORFSpectrum - output RF spectrum (GSM, EDGE mode)	RFEMod ($n=2$) ^a RFESwitching ($n=3$) ^a SPEMod ($n=4$) ^a LIMMod ($n=5$) ^a ($n=0$) ^a for I/Q points	yes, only for a single offset yes, only for multiple offsets
PFERror - phase and frequency error (GSM, EDGE mode)	PERRor ($n=2$) ^a PFERror ($n=3$) ^a RFENvelope ($n=4$) ^a ($n=0$) ^a for I/Q points	yes
PSTatistic - power statistics CCDF (Basic, cdma2000, W-CDMA, 1xEV-DO modes)	MEASured ($n=2$) ^a GAUSSian ($n=3$) ^a REFerence ($n=4$) ^a ($n=0$) ^a for I/Q points	yes

Measurement	Available Traces	Markers Available?
PVTime - power versus time (GSM, EDGE, 1xEV-DO, Service (E4406A only) modes)	RFENvelope ($n=2$) ^a UMASk ($n=3$) ^a LMASk ($n=4$) ^a ($n=0$) ^a for I/Q points	yes
RHO - modulation quality (cdmaOne, cdma2000, W-CDMA, 1xEV-DO mode)	($n=0$) ^a for I/Q points EVM ($n=2$) ^a MERRor ($n=3$) ^a PERRor ($n=4$) ^a ($n=0$) ^a for I/Q points	yes
SEMask - spectrum emissions mask (cdma2000, W-CDMA, 1xEV-DO mode)	SPECTrum ($n=2$) ^a ($n=0$) ^a for I/Q points	yes
TSPur - transmit band spurs (GSM, EDGE mode)	SPECTrum ($n=2$) ^a ULIMit ($n=3$) ^a ($n=0$) ^a for I/Q points	yes
TXPower - transmit power (GSM, EDGE mode)	RFENvelope ($n=2$) ^a IQ ($n=8$) ^a ($n=0$) ^a for I/Q points	yes
SPECTrum - (frequency domain) (all modes)	RFENvelope ($n=2$) ^a for Service mode (E4406A only) IQ ($n=3$) ^a SPECTrum ($n=4$) ^a ASPECTrum ($n=7$) ^a ($n=0$) ^a for I/Q points	yes
WAVEform - (time domain) (all modes)	RFENvelope ($n=2$) ^a (also for Signal Envelope trace) IQ ($n=5$) ^a ($n=0$) ^a for I/Q points	yes

CALCulate Subsystem

- a. The n number indicates the sub-opcode that corresponds to this trace. Detailed descriptions of the trace data can be found in the MEASure subsystem documentation by looking up the sub-opcode for the appropriate measurement.

Marker X Value

:CALCulate:<measurement>:MARKer[1]|2|3|4:X <param>

:CALCulate:<measurement>:MARKer[1]|2|3|4:X?

Position the designated marker on its assigned trace at the specified X value. The parameter value is in X-axis units (which is often frequency or time).

The marker must have already been assigned to a trace. Use

:CALCulate:<measurement>:MARKer[1]|2|3|4:TRACe to assign a marker to a particular trace.

The query returns the current X value of the designated marker. The measurement must be completed before querying the marker.

Example: **CALC:SPEC:MARK2:X 1.2e6 Hz**

Range: For Phase Noise mode: Graph Start Offset and Stop Offset frequencies.

Default Unit: Matches the units of the trace on which the marker is positioned

Remarks: The keyword for the current measurement must be specified in the command. (Some examples include: LPLot, ACP, WAVeform)

Front Panel

Access: **Marker, <active marker>, RPG**

Marker X Position

:CALCulate:<measurement>:MARKer[1]|2|3|4:X:POStion <integer>

:CALCulate:<measurement>:MARKer[1]|2|3|4:X:POStion?

Position the designated marker on its assigned trace at the specified X position. A trace is composed of a variable number of measurement points. This number changes depending on the current measurement conditions. The current number of points must be identified before using this command to place the marker at a specific location.

The marker must have already been assigned to a trace. Use

:CALCulate:<measurement>:MARKer[1]|2|3|4:TRACe to assign a marker to a particular trace.

The query returns the current X position for the designated marker. The measurement must be completed before querying the marker.

Example: **CALC:SPEC:MARK:X:POS 500**

Range: 0 to a maximum of (3 to 920,000)

Remarks: The keyword for the current measurement must be specified in the command. (Some examples include: SPECTrum, WAVEform)

Front Panel

Access: **Marker, <active marker>, RPG**

Marker Readout Y Value

:CALCulate:<measurement>:MARKer[1] | 2 | 3 | 4:Y?

Readout the current Y value for the designated marker on its assigned trace. The value is in the Y-axis units for the trace (which is often dBm).

The marker must have already been assigned to a trace. Use

:CALCulate:<measurement>:MARKer[1] | 2 | 3 | 4:TRACe to assign a marker to a particular trace.

The measurement must be completed before querying the marker.

Example: **CALC:SPEC:MARK1:Y?**

Default Unit: Matches the units of the trace on which the marker is positioned

Remarks: The keyword for the current measurement must be specified in the command. (Some examples include: LPLot, ACP, WAVEform)

CALCulate Subsystem

Occupied Bandwidth - Limits

Occupied Bandwidth—Frequency Band Limit

PDC, cdma2000, W-CDMA, 1xEV-DO mode

:CALCulate:OBW:LIMit:FBLimit <freq>

:CALCulate:OBW:LIMit:FBLimit?

iDEN mode (E4406A only)

:CALCulate:OBWidth:LIMit:FBLimit <freq>

:CALCulate:OBWidth:LIMit:FBLimit?

Set the frequency bandwidth limit in Hz.

Factory Preset: 32 kHz for PDC

20 kHz for iDEN (E4406A only)

1.48 MHz for cdma2000, 1xEV-DO

5 MHz for W-CDMA

Range: 10 kHz to 60 kHz for PDC, iDEN (E4406A only)

10 kHz to 10 MHz for cdma2000, W-CDMA, 1xEV-DO

Default Unit: Hz

Remarks: You must be in the iDEN (E4406A only), PDC, cdma2000, W-CDMA, or 1xEV-DO mode to use this command. Use INSTRument:SElect to set the mode.

History: For E4406A:
Version A.02.00 or later

Occupied Bandwidth—Limit Test

PDC, cdma2000, W-CDMA, 1xEV-DO mode

:CALCulate:OBW:LIMit[:TEST] OFF|ON|0|1

:CALCulate:OBW:LIMit[:TEST]?

iDEN mode (E4406A only)

:CALCulate:OBWidth:LIMit:STATE OFF|ON|0|1

:CALCulate:OBWidth:LIMit:STATE?

Turn the limit test function on or off.

Factory Preset: ON

Remarks: You must be in the iDEN (E4406A only), PDC, cdma2000, W-CDMA, or 1xEV-DO mode to use this command. Use

INSTRument:SElect to set the mode.

History:

For E4406A:

Version A.02.00 or later

CALCulate Subsystem

Power Control Commands

Power Control—Measurement Interval

:CALCulate:PCONtrol:PRACH:INTerval <float>

:CALCulate:PCONtrol:PRACH:INTerval?

Set Off-Power Measurement Interval for PRACH Power Measurement in chips.

Factory Preset: 2368.0 chips

Range: 1.0 to 12800.0 chips

Remarks: You must be in the W-CDMA mode to use this command. Use INSTRument:SElect to set the mode.

Power Control—PRACH Message Length

:CALCulate:PCONtrol:PRACH:MLENght <float>

:CALCulate:PCONtrol:PRACH:MLENght?

Set Message Length for PRACH Power Measurement in seconds.

Factory Preset: 0.02 s (20 ms)

Range: 0.01 s (10 ms) or 0.02 s (20 ms)

The number between 10 ms and 20 ms is rounded to the nearest number, either 10 ms or 20 ms.

Remarks: You must be in the W-CDMA mode to use this command. Use INSTRument:SElect to set the mode.

Power Control—Measurement Offset

:CALCulate:PCONtrol:PRACH:OFFSet <float>

:CALCulate:PCONtrol:PRACH:OFFSet?

Set Meas Offset (excluding period before and after reference point due to transient) for PRACH Power Measurement.

Factory Preset: 96.0 chips

Range: 0.0 to 200.0 chips

Remarks: You must be in the W-CDMA mode to use this command. Use INSTRument:SElect to set the mode.

Power Control—PRACH Preamble Length

:CALCulate:PCONtrol:PRACH:PLENght <float>

:CALCulate:PCONtrol:PRACH:PLENght?

Set Preamble Length for PRACH Power Measurement.

Factory Preset: 4096.0 chips

Range: 4000.0 to 4200.0 chips

Remarks: You must be in the W-CDMA mode to use this command. Use INSTRument:SElect to set the mode.

Power Control—Measurement Delay

:CALCulate:PCONtrol:SLOT:DELay <float>

:CALCulate:PCONtrol:SLOT:DELay?

Set Meas Delay for Slot Power Measurement in chips.

Factory Preset: 96.0 chips

Range: 0.0 to (:CALCulate:PCONtrol:SLOT:LENGth – :CALCulate:PCONtrol:SLOT:INTerval) chips

Remarks: You must be in the W-CDMA mode to use this command. Use INSTRument:SElect to set the mode.

Power Control—Measurement Interval

:CALCulate:PCONtrol:SLOT:INTerval <float>

:CALCulate:PCONtrol:SLOT:INTerval?

Set Meas Interval for Slot Power Measurement in chips.

Factory Preset: 2368.0 chips

Range: 1.0 to (:CALCulate:PCONtrol:SLOT:LENGth – :CALCulate:PCONtrol:SLOT:OFFSet) chips

Remarks: You must be in the W-CDMA mode to use this command. Use INSTRument:SElect to set the mode.

Power Control—PCG(Slot) Length

:CALCulate:PCONtrol:SLOT:LENGth <float>

:CALCulate:PCONtrol:SLOT:LENGth?

Set PCG Length for Slot Power Measurement in chips.

Factory Preset: 2560.0 chips

Range: 2048.0 to 25600.0 chips

CALCulate Subsystem

Remarks: You must be in the W-CDMA mode to use this command. Use INSTRUMENT:SElect to set the mode.

Power Control—Slot Offset Timing

:CALCulate:PCONTrol:SLOT:OFFSet <float>

:CALCulate:PCONTrol:SLOT:OFFSet?

Set the Slot Offset value in chips.

Factory Preset: 0 chips

Range: 0.0 to 5120.0 chips

Remarks: You must be in the W-CDMA mode to use this command. Use INSTRUMENT:SElect to set the mode.

Power Statistic CCDF—Store Reference

:CALCulate:PStAtistic:STORe:REFerence ON|1

Store the currently measured trace as the user-defined reference trace. No query command is available.

Remarks: You must be in the cdma2000, W-CDMA, or 1xEV-DO mode to use this command. Use INSTRument:SELEct to set the mode.

CALCulate Subsystem

Modulation Accuracy - Limits

Modulation Accuracy (Rho)—Active Set Threshold

:CALCulate:RHO:ASET:THReshold <numeric>

:CALCulate:RHO:ASET:THReshold?

Set the threshold level for the active channel identification function.

Factory Preset: 0.0 dBm

Range: -100.0 to 0.0 dB

Remarks: You must be in W-CDMA, cdma2000, or 1xEV-DO mode to use this command. Use INSTRument:SElect to set the mode.

Modulation Accuracy (Rho)—Active Set Threshold Mode

:CALCulate:RHO:ASET:THReshold:AUTO OFF|ON|0|1

:CALCulate:RHO:ASET:THReshold:AUTO?

Turn the automatic mode On or Off, for the active channel identification function.

OFF – The active channel identification for each code channel is determined by a value set by `CALCulate:RHO:ASET:THReshold`.

ON – The active channels are determined automatically by the internal algorithm.

Factory Preset: ON

Remarks: You must be in W-CDMA, cdma2000, or 1xEV-DO mode to use this command. Use INSTRument:SElect to set the mode.

Modulation Accuracy (Rho)—Rho Result I/Q Offset

:CALCulate:RHO:IQOFFset:INCLude OFF|ON|0|1

:CALCulate:RHO:IQOFFset:INCLude?

Turn the automatic mode On or Off, for the I/Q origin offset function.

OFF – The measurement results for EVM and Rho do not take into account the I/Q origin offset.

ON – The measurement results for EVM and Rho take into account the I/Q origin offset.

Factory Preset: ON

Remarks: You must be in the 1xEV-DO mode to use this command. Use INSTRument:SElect to set the mode.

Modulation Accuracy (Rho)—Code Domain Error Limit (BTS)

:CALCulate:RHO:LIMit:CDERror <float>

:CALCulate:RHO:LIMit:CDERror?

Set the Peak Code Domain Error limit in dB.

Factory Preset: 0.0 dB for cdma2000
 -32.0 dB for W-CDMA

Range: -100.0 to 0.0 dB

Remarks: You must be in the cdma2000 or W-CDMA mode to use this command. Use INSTRument:SElect to set the mode.

Modulation Accuracy (Rho)—CPICH Error Limit (BTS)

:CALCulate:RHO:LIMit:CPICH[:BTS] <float>

:CALCulate:RHO:LIMit:CPICH[:BTS]?

Set the Frequency Error limit in Hz. The limit value set by this command is only used, when the [:SENSe]:RADio:DEvice is set to BTS.

Factory Preset: 2.9 dB

Range: 0.0 to 20.0 dB

Remarks: You must be in the W-CDMA mode to use this command. Use INSTRument:SElect to set the mode.

Modulation Accuracy (Rho)—CPICH Reference Power (BTS)

:CALCulate:RHO:LIMit:CPICH[:BTS]:POWER <float>

:CALCulate:RHO:LIMit:CPICH[:BTS]:POWER?

Set the CPICH Reference Power (relative power to total carrier power) in dB. The limit value set by this command is only used, when the [:SENSe]:RADio:DEvice is set to BTS.

Factory Preset: -10.0 dB

Range: -100.0 to 0.0 dB

Remarks: You must be in the W-CDMA mode to use this command. Use INSTRument:SElect to set the mode.

CALCulate Subsystem

Modulation Accuracy (Rho)—Min Data Active Power

:CALCulate:RHO:LIMit:DATA[:ACTive][:LOWER] <float>

:CALCulate:RHO:LIMit:DATA[:ACTive][:LOWER]?

Specify the DATA Active Power minimum limit value in dB.

Factory Preset: -15.55 dB

Range: -100.0 to
:CALCulate:RHO:LIMit:DATA[ACTive][:UPPer]dB

Remarks: You must be in the 1xEV-DO mode to use this command. Use INSTRument:SElect to set the mode.

Modulation Accuracy (Rho)—Max Data Active Power

:CALCulate:RHO:LIMit:DATA[:ACTive][:UPPer] <float>

:CALCulate:RHO:LIMit:DATA[:ACTive][:UPPer]?

Specify the DATA Active Power maximum limit value in dB.

Factory Preset: -14.56 dB

Range: -100.0 to 0.0 dB

Remarks: You must be in the 1xEV-DO mode to use this command. Use INSTRument:SElect to set the mode.

Modulation Accuracy (Rho)—Frequency Error Limit

:CALCulate:RHO:LIMit:FERRor <float>

:CALCulate:RHO:LIMit:FERRor?

Set the Frequency Error limit in Hz.

Factory Preset: 100.0 Hz

Range: 0.0 to 500.0 Hz

Remarks: You must be in the W-CDMA mode to use this command. Use INSTRument:SElect to set the mode.

Modulation Accuracy (Rho)—Frequency Error Limit

:CALCulate:RHO:LIMit:FREQuency <numeric>

:CALCulate:RHO:LIMit:FREQuency?

Specify a limit value in ppm for the frequency error test.

Factory Preset: 0.05 ppm

Range: 0.0 to 1.0 ppm
 Unit: ppm
 Remarks: You must be in the 1xEV-DO mode to use this command. Use INSTRUMENT:SElect to set the mode.
 Front Panel
 Access: **Meas Setup, More, Limits...**

Modulation Accuracy (Rho)—Max MAC Inactive Power

:CALCulate:RHO:LIMit:MAC:INACTive[:UPPer]<float>

:CALCulate:RHO:LIMit:MAC:INACTive[:UPPer]?

Specify the MAC inactive power limit value in dB.

Factory Preset: -27.00 dB
 Range: -100.0 to 0 dB
 Unit: ppm
 Remarks: You must be in the 1xEV-DO mode to use this command. Use INSTRUMENT:SElect to set the mode.
 Front Panel
 Access: **Meas Setup, More, Limits...**

Modulation Accuracy (Rho)—Peak EVM Limit

:CALCulate:RHO:LIMit:PEAK <float>

:CALCulate:RHO:LIMit:PEAK?

Specify a limit value in percent for the peak EVM test.

Factory Preset: 100.0%
 Range: 0.0 to 200.0%
 Remarks: You must be in the cdma2000, W-CDMA, or 1xEV-DO mode to use this command. Use INSTRUMENT:SElect to set the mode.

Modulation Accuracy (Rho)—Peak EVM Limit (MS)

:CALCulate:RHO:LIMit:PEAK:MS <float>

:CALCulate:RHO:LIMit:PEAK:MS?

Set the peak code domain error limit in dB.

Factory Preset: 100.0%

CALCulate Subsystem

Range: 0.0 to 200.0%

Remarks: You must be in the W-CDMA mode to use this command. Use INSTRument:SElect to set the mode.

Modulation Accuracy (Rho)—Phase Error Limit

:CALCulate:RHO:LIMit:PHASe <float>

:CALCulate:RHO:LIMit:PHASe?

Specify a limit value in radian for the phase error test.

Factory Preset: 0.05 rad

Range: 0.00 to 3.00 rad

Remarks: You must be in the cdma2000 or 1xEV-DO mode to use this command. Use INSTRument:SElect to set the mode.

Modulation Accuracy (Rho)—Pilot Time Offset Limit

:CALCulate:RHO:LIMit:POFFset <float>

:CALCulate:RHO:LIMit:POFFset?

Specify a limit value for the Pilot time offset test from the external trigger.

Factory Preset: 10.0 μ s

Range: 0.0 to 100.0 μ s

Remarks: You must be in the 1xEV-DO mode to use this command. Use INSTRument:SElect to set the mode.

Modulation Accuracy (Rho)—Rho Limit

:CALCulate:RHO:LIMit:RHO <float>

:CALCulate:RHO:LIMit:RHO?

Specify a limit value for the Rho test.

Factory Preset: 0.5

Range: 0 to 1.0

Remarks: You must be in the cdma2000, W-CDMA, or 1xEV-DO mode to use this command. Use INSTRument:SElect to set the mode.

Modulation Accuracy (Rho)—RMS EVM Limit**:CALCulate:RHO:LIMit:RMS <float>****:CALCulate:RHO:LIMit:RMS?**

Specify a limit value in percent for the rms EVM test.

Factory Preset: 17.5%

Range: 0.0 to 100.0%

Remarks: You must be in the cdma2000, W-CDMA, or 1xEV-DO mode to use this command. Use INSTRument:SElect to set the mode.

Modulation Accuracy (Rho)—Time Offset Limit**:CALCulate:RHO:LIMit:TIMing <float>****:CALCulate:RHO:LIMit:TIMing?**

Specify a limit value in second for the time offset test.

Factory Preset: 0.00000005 s (50 ns)

Range: 0 to 0.0000005 s (0 to 500 ns)

Remarks: You must be in the cdma2000 or 1xEV-DO mode to use this command. Use INSTRument:SElect to set the mode.

Modulation Accuracy (Rho)— Pseudo-Random Noise Offset**:CALCulate:RHO:PNOFfset <time>****:CALCulate:RHO:PNOFfset?**

Sets value for the psuedo-random noise offset. Different psuedo-random noise offsets are used for different base stations. By setting the pseudo-random noise offset to the value that your specific base station is set to, you get the correct time offset value displayed and returned back to you when you query READ:RHO?. The instrument, by default, assumes an offset of 0. So if you do not use this command you will have to manually calculate the time offset when the value is other than 0.

Factory Preset: 0 chips offset

Range: 0 to 511 (× 64 chips) 1 = 64 chip offset, 2 = 128 chips

Remarks: You must be in the cdma2000 mode to use this command. Use INSTRument:SElect to set the mode.

Modulation Accuracy (Rho)—Channel Type**:CALCulate:RHO:TYPE ALL|DATA|MAC|PILot|PREamble**

CALCulate Subsystem

:CALCulate:RHO:TYPE?

Select one of the following channel types to be used measurements.

ALL – measure Rho Overall-1 and Rho Overall-2 as specified in 3GPP2 TSG-4.1 Recommended Minimum Performance Standard for cdma2000 High Rate Data Packet Access Network, 11.4.2. Waveform Quality Measurement section.

DATA – measure the data channel.

MAC – measure the medium access control (MAC) channel.

PILOt – measure the Pilot channel.

PREamble – measure the preamble data chips overlaid on the data channel.

Factory Preset: PILOt

Remarks: You must be in the 1xEV-DO mode to use this command. Use INSTRument:SElect to set the mode.

Modulation Accuracy (Rho)—Data Type

:CALCulate:RHO:TYPE:DATA OPSK|QAM|QPSK

:CALCulate:RHO:TYPE:DATA?

Select one of the following data types to be used for encoding.

OPSK – Eight phase shift keying (8PSK)

QAM – Sixteen quadrature amplitude modulation (16QAM)

QPSK – Quadrature phase shift keying

Factory Preset: QPSK

Remarks: You must be in the 1xEV-DO mode to use this command. Use INSTRument:SElect to set the mode.

Terminal Modulation Accuracy - Limits

Terminal Modulation Accuracy (Rho)—Active Set Threshold

:CALCulate:TRHO:ASET:THReshold <numeric>

:CALCulate:TRHO:ASET:THReshold?

Set the threshold level for the active channel identification function.

Factory Preset: 0.0 dB

Range: -100.0 to 0.0 dB

Remarks: You must be in the 1xEV-DO mode to use this command. Use INSTRument:SElect to set the mode.

Terminal Modulation Accuracy (Rho)—Active Set Threshold Mode

:CALCulate:TRHO:ASET:THReshold:AUTO OFF|ON|0|1

:CALCulate:TRHO:ASET:THReshold:AUTO?

Turn the automatic mode On or Off, for the active channel identification function.

OFF – The active channel identification for each code channel is determined by a value set by CALCulate:RHO:ASET:THReshold.

ON – The active channels are determined automatically by the internal algorithm.

Factory Preset: ON

Remarks: You must be in 1xEV-DO mode to use this command. Use INSTRument:SElect to set the mode.

Terminal Modulation Accuracy (Rho)—I/Q Offset Include

:CALCulate:TRHO:IQOFFset:INCLude OFF|ON|0|1

:CALCulate:TRHO:IQOFFset:INCLude?

Turn the automatic mode On or Off, for the I/Q origin offset function.

OFF – The measurement results for EVM and Rho do not include the I/Q origin offset.

ON – The measurement results for EVM and Rho include the I/Q origin offset.

Factory Preset: ON

Remarks: You must be in the 1xEV-DO mode to use this command. Use INSTRument:SElect to set the mode.

CALCulate Subsystem

Terminal Modulation Accuracy (Rho)—Active Code Domain Power Tolerance

:CALCulate:TRHO:LIMit:ACDPower <float>

:CALCulate:TRHO:LIMit:ACDPower?

Set the Active Code Domain Power tolerance limit in dB.

Factory Preset: 0.25 dB

Range: 0.0 to 3.0 dB

Remarks: You must be in the 1xEV-DO mode to use this command. Use INSTRument:SElect to set the mode.

Terminal Modulation Accuracy (Rho)—ACK Channel Power Gain

:CALCulate:TRHO:LIMit:ACK:GAIN <float>

:CALCulate:TRHO:LIMit:ACK:GAIN?

Set the ACK channel power gain in dB.

Factory Preset: 3.0 dB

Range: -10.0 to 10.0 dB

Remarks: You must be in the 1xEV-DO mode to use this command. Use INSTRument:SElect to set the mode.

Terminal Modulation Accuracy (Rho)—Peak Code Domain Error Limit

:CALCulate:TRHO:LIMit:CDERror <float>

:CALCulate:TRHO:LIMit:CDERror?

Set the Peak Code Domain Error limit in dB.

Factory Preset: -40.0 dB

Range: -100.0 to 0.0 dB

Remarks: You must be in the 1xEV-DO mode to use this command. Use INSTRument:SElect to set the mode.

Terminal Modulation Accuracy (Rho)—Data Channel Power Gain

:CALCulate:TRHO:LIMit:DATA:GAIN <float>

:CALCulate:TRHO:LIMit:DATA:GAIN?

Set the Data channel power gain in dB.

Factory Preset: 3.75 dB

Range: -10.0 to 10.0 dB
 Remarks: You must be in the 1xEV-DO mode to use this command. Use INSTRUMENT:SELEct to set the mode.

Terminal Modulation Accuracy (Rho)—DRC Channel Power Gain

:CALCulate:TRHO:LIMit:DRC:GAIN <float>

:CALCulate:TRHO:LIMit:DRC:GAIN?

Set the DRC channel power gain in dB.

Factory Preset: 3.0 dB

Range: -10.0 to 10.0 dB

Remarks: You must be in the 1xEV-DO mode to use this command. Use INSTRUMENT:SELEct to set the mode.

Terminal Modulation Accuracy (Rho)—Frequency Error Limit

:CALCulate:TRHO:LIMit:FERRor <float>

:CALCulate:TRHO:LIMit:FERRor?

Set the Frequency Error limit in Hz.

Factory Preset: 300.0 Hz

Range: 0.0 to 10.0 kHz

Remarks: You must be in the 1xEV-DO mode to use this command. Use INSTRUMENT:SELEct to set the mode.

Terminal Modulation Accuracy (Rho)—Inactive Channel CDP

:CALCulate:TRHO:LIMit:ICDPower <float>

:CALCulate:TRHO:LIMit:ICDPower?

Specify the Max inactive code domain power limit value in dBc.

Factory Preset: -23.00 dBc

Range: -100.0 to 0 dBc

Remarks: You must be in the 1xEV-DO mode to use this command. Use INSTRUMENT:SELEct to set the mode.

Front Panel

Access: **Meas Setup, More, Limits...**

CALCulate Subsystem

Terminal Modulation Accuracy (Rho)—Peak EVM Limit

:CALCulate:TRHO:LIMit:PEAK <float>

:CALCulate:TRHO:LIMit:PEAK?

Specify a limit value in percent for the peak EVM test.

Factory Preset: 100.0%

Range: 0.0 to 200.0%

Resolution: 0.1%

Step: 0.1%

Remarks: You must be in the 1xEV-DO mode to use this command. Use INSTRument:SElect to set the mode.

Terminal Modulation Accuracy (Rho)—Pilot Time Offset Limit

:CALCulate:TRHO:LIMit:POFFset <float>

:CALCulate:TRHO:LIMit:POFFset?

Specify a limit value for the Pilot time offset test from the external trigger.

Factory Preset: 1.0 μ s

Range: 0.0 to 100.0 ms

Remarks: You must be in the 1xEV-DO mode to use this command. Use INSTRument:SElect to set the mode.

Terminal Modulation Accuracy (Rho)—Rho Limit

:CALCulate:TRHO:LIMit:RHO <float>

:CALCulate:TRHO:LIMit:RHO?

Specify a limit value for the Rho test.

Factory Preset: 0.5

Range: 0 to 1.0

Remarks: You must be in the 1xEV-DO mode to use this command. Use INSTRument:SElect to set the mode.

Terminal Modulation Accuracy (Rho)—RMS EVM Limit

:CALCulate:TRHO:LIMit:RMS <float>

:CALCulate:TRHO:LIMit:RMS?

Specify a limit value in percent for the rms EVM test.

Factory Preset: 50.0%

Range: 0.0 to 100.0%

Remarks: You must be in the 1xEV-DO mode to use this command. Use INSTRUMENT:SELEct to set the mode.

Terminal Modulation Accuracy (Rho)—RRI Relative Power Limit

:CALCulate:TRHO:LIMit:RRI <float>

:CALCulate:TRHO:LIMit:RRI?

Specify a tolerance limit for the RRI Power (ratio to Pilot) value in dB.

Factory Preset: 0.25 dB

Range: 0.00 to 3.00

Remarks: You must be in the 1xEV-DO mode to use this command. Use INSTRUMENT:SELEct to set the mode.

CALCulate Subsystem

Baseband I/Q - Spectrum I/Q Marker Query

:CALCulate:SPECTrum:MARKer:IQ [1] | 2 | 3 | 4?

Reads out current I and Q marker values.

Remarks: You must be in the Basic, W-CDMA, cdma2000 mode to use this command. Use INSTRument:SElect to set the mode.

History: Added revision A.05.00

Transmit Band Spurious - Limits

Transmit Band Spurs—Type of Limit Testing

:CALCulate:TSPur:LIMit:TEST ABSolute|RELative

:CALCulate:TSPur:LIMit:TEST?

Select the limit testing to be done using either absolute or relative power limits.

Factory Preset: Absolute

Remarks: You must be in the GSM, EDGE(w/GSM) mode to use this command. Use INSTRument:SElect to set the mode.

History: Version A.03.00 or later

Front Panel

Access: **Meas Setup, Limit**

Transmit Band Spurs—Define Limits

:CALCulate:TSPur:LIMit[:UPPer][:DATA] <power>

:CALCulate:TSPur:LIMit[:UPPer][:DATA]?

Set the value for the test limit. This command does not accept units. Use CALCulate:TSPur:LIMit:TEST to select the units dBm (absolute) or dB (relative).

Factory Preset: -36

Range: -200 to 100

Remarks: You must be in the GSM, EDGE (w/GSM) mode to use this command. Use INSTRument:SElect to set the mode.

History: Version A.03.00 or later

Front Panel

Access: **Meas Setup, Limit**

CALCulate Subsystem

Baseband I/Q - Waveform I/Q Marker Query

:CALCulate:WAVEform:MARKer:IQ [1] | 2 | 3 | 4?

Reads out current I and Q marker values.

Remarks: You must be in the Basic, W-CDMA, cdma2000 mode to use this command. Use INSTRument:SElect to set the mode.

History: Added revision A.05.00

CALibration Subsystem

These commands control the self-alignment and self-diagnostic processes.

Numeric values for bit patterns can be entered using decimal or hexadecimal representations. (i.e. 0 to 32767 is equivalent to #H0 to #H7FFF) See the SCPI Basics information about using bit patterns for variable parameters.

NOTE

For E4406A, most CALibration commands execute in the background, permitting other SCPI commands to be processed concurrently. If a measurement command is sent right after a CALibration command, there can be interaction between background alignments and the measurement. The *WAI command should be issued after any CALibration command and before the measurement command. Note that sending the query form of a CAL? command will automatically hold off any following commands until the query value is returned.

Bit 0 (CALibraion) must be set to 1 in the STATus:OPERation:ENABLE register to ensure that the *WAI command waits for calibration to complete. This is the factory preset and *RST setting.

Calibration Abort

:CALibration:ABORT

Abort any alignment in progress.

Front Panel

Access: **ESC**, when alignment is in progress

Align the ADC Auto-range Threshold

:CALibration:ADC:ARANge

:CALibration:ADC:ARANge?

Align the ADC auto-range thresholds. This same alignment is run as part of the CAL:ALL routine.

The query performs the alignment and returns a zero if the alignment is successful.

Front Panel

Access: **System, Alignments, Align subsystem, Align ADC**

Align the ADC Dither Center Frequency

`:CALibration:ADC:DITHer`

`:CALibration:ADC:DITHer?`

Align the ADC dithering center frequency. This same alignment is run as part of the CAL:ALL routine.

The query performs the alignment and returns a zero if the alignment is successful.

Front Panel

Access: **System, Alignments, Align subsystem, Align ADC**

Align the ADC Offset

`:CALibration:ADC:OFFSet`

`:CALibration:ADC:OFFSet?`

Align the six ADC offset DACs. This same alignment is run as part of the CAL:ALL routine.

The query performs the alignment and returns a zero if the alignment is successful.

Front Panel

Access: **System, Alignments, Align subsystem, Align ADC**

Align the ADC RAM Gain

`:CALibration:ADCRam:GAIN`

`:CALibration:ADCRam:GAIN?`

Align the gain of the six ADC RAM pages. This same alignment is run as part of the CAL:ALL routine.

The query performs the alignment and returns a zero if the alignment is successful.

Front Panel

Access: **System, Alignments, Align subsystem, Align ADC**

Align All Instrument Assemblies

`:CALibration[:ALL]`

`:CALibration[:ALL]?`

Performs an alignment of all the assemblies within the instrument.

The query performs a full alignment and returns a zero if the alignment is successful. A one is returned if any part of the alignment failed.

Front Panel

Access: **System, Alignments, Align All Now**

Calibrate the Attenuator

`:CALibration:ATTenuator`

`:CALibration:ATTenuator?`

Calculate the gain error of 40 RF attenuator steps. The nominal setting of 10 dB is assumed to have 0 dB error.

The query performs the alignment and returns a zero if the alignment is successful.

Remarks: A valid service password needs to be entered prior to sending the command.

Front Panel

Access: **System, Alignments, Align subsystem, RF**

Automatic Alignment

`:CALibration:AUTO OFF|ALERT|ON`

`:CALibration:AUTO?`

Turns the automatic alignment routines on and off. When turned on, they are run once every 5 minutes, or if the ambient temperature changes by 3 degrees.

If alignment is turned off, the instrument may drift out of specification. The alert mode allows you to turn off the automatic alignment, but reminds you to when to run the alignment again. You will get a warning message if 24 hours has expired or the temperature has change by 3 degrees since the last alignment.

Factory Preset: Alert

Your setting for the auto alignment is persistent and will remain the same even through an instrument power cycle.

Front Panel

Access: **System, Alignments, Auto Align**

Calibration Comb Alignment

:CALibration:COMB

:CALibration:COMB?

Aligns the comb frequencies by measuring them relative to the internal 50 MHz reference signal.

The query performs the alignment and returns a zero if the alignment is successful.

Remarks: A valid service password needs to be entered prior to sending the command.

Front Panel

Access: System, Alignments, Align Subsystem, RF

Turn Background Calibration Corrections Off

:CALibration:CORRections 0|1|OFF|ON

:CALibration:CORRections?

When set to OFF deactivates background flatness and IF gain alignments, for which nominal values are substituted. Several video shift gain corrections are set to zero, including absolute gain err, gain err vs attenuation, and RF flatness err vs frequency. The IF gain DAC is not compensated to adjust for prefilter gain but is set to a nominal value. Typically used to facilitate troubleshooting.

Factory Preset: ON

Front Panel Access: System, Alignment, Corrections

Calibration Display Detail

:CALibration:DISPlay:LEVEl OFF|LOW|HIGH

:CALibration:DISPlay:LEVEl?

Controls the amount of detail shown on the display while the alignment routines are running. The routines run faster if the display level is off, so they do not have to update the display.

Off - displays no trace points

Low - displays every 10th trace

High - displays every trace

Factory Preset: Low

Front Panel
Access: **System, Alignments, Visible Align**

Align the Image Filter Circuitry

`:CALibration:FILTer:IMAGe`

`:CALibration:FILTer:IMAGe?`

Align the eight image filter tuning DACs.

The query performs the alignment and returns a zero if the alignment is successful.

Remarks: A valid service password needs to be entered prior to sending the command.

Front Panel
Access: **System, Diagnostics**

Align the IF Flatness

`:CALibration:FLATness:IF`

`:CALibration:FLATness:IF?`

Finds the flatness shape of the current IF setup (prefilter, mgain, natBW). This information is then used for compensating measurements that use FFT functionality, like the spectrum measurement. The alignment is done frequently in the background. This same alignment is run as part of the CAL:ALL routine.

The query performs the alignment and returns a zero if the alignment is successful.

Front Panel
Access: **Select Timebase Freq under Measure, then press Meas Setup, Auto Adjust Now.**

Auto Adjust the Internal 10 MHz Frequency Reference

`:CALibration:FREQuency:REFerence:AADJust`

Auto adjustment of the internal frequency reference (10 MHz timebase). .

Remarks: You must be in the Service mode to use this command. Use INSTRument:SElect.

CALibration Subsystem

Requires the current measurement to be timebase frequency. A valid password needs to be entered sometime prior to sending this command. See the timebase frequency measurement for more information.

Front Panel

Access: Select **Timebase Freq** under **Measure**, then press **Meas Setup, Auto Adjust Now**.

Align the ADC

`:CALibration:GADC`

`:CALibration:GADC?`

Performs the ADC group of alignments. The query returns a 0 if the alignments occurred without problems.

The query performs the alignment and returns a zero if the alignment is successful.

Front Panel

Access: **System, Alignments, Align Subsystem, Align ADC**

Align the IF Gain

`:CALibration:GAIN:IF`

`:CALibration:GAIN:IF?`

Calculate the curve coefficients for the IF gain DAC.

The query performs the alignment and returns a zero if the alignment is successful.

Front Panel

Access: **System, Alignments, Align Subsystem, IF**

Calibrate the Nominal System Gain

`:CALibration:GAIN:CSYSTEM`

`:CALibration:GAIN:CSYSTEM?`

Calculate the current system gain correction for nominal settings. That is, with 10 dB attenuation, 500 MHz center frequency, 0 dB IF gain and the prefilter off.

Front Panel

Access: **System, Alignments, Align Subsystem, IF**

Align the IF

:CALibration:GIF

:CALibration:GIF?

Performs the IF group of alignments. The query returns a 0 if the alignments occurred without problems.

The query performs the alignment and returns a zero if the alignment is successful.

Front Panel

Access: **System, Alignments, Align Subsystem, Align IF**

Baseband I/Q - Align the Baseband IQ

:CALibration:GIQ

:CALibration:GIQ?

Performs the IQ group of alignments. The query performs the alignment and returns a 0 if the alignment is successful.

Remarks: You must be in the Basic, W-CDMA, cdma2000 mode to use this command. Use INSTRument:SElect to set the mode.

History: Added revision A.05.00

Align the RF

:CALibration:GRF

:CALibration:GRF?

Performs the RF group of alignments. The query returns a 0 if the alignments occurred without problems.

The query performs the alignment and returns a zero if the alignment is successful.

Front Panel

Access: **System, Alignments, Align Subsystem, Align RF**

Baseband I/Q - IQ Common Mode Response Null

:CALibration:IQ:CMR

:CALibration:IQ:CMR?

Forces a common mode response null on I/Q inputs.

CALibration Subsystem

Remarks: You must be in the Basic, W-CDMA, cdma2000 mode to use this command. Use INSTRUMENT:SElect to set the mode.

History: Added revision A.05.00

Baseband I/Q - IQ Flatness Calibration

`:CALibration:IQ:FLATness`

`:CALibration:IQ:FLATness?`

Activates a flatness calibration for all I/Q ranges and impedance settings.

Remarks: You must be in the Basic, W-CDMA, cdma2000 mode to use this command. Use INSTRUMENT:SElect to set the mode.

History: Added revision A.05.00

Baseband I/Q - IQ Offset Calibration

`:CALibration:IQ:OFFSet`

`:CALibration:IQ:OFFSet?`

Activates a calibration of the I/Q input offset DAC.

Remarks: You must be in the Basic, W-CDMA, cdma2000 mode to use this command. Use INSTRUMENT:SElect to set the mode.

History: Added revision A.05.00

Load the Factory Default Calibration Constants

`:CALibration:LOAD:DEFault`

Load the factory default alignment data, ignoring the effect of any alignments already done.

Front Panel

Access: System, Alignments, Restore Align Defaults

Align the Narrow LC Prefilter

`:CALibration:PFILter:LC:NARRow`

:CALibration:PFILter:LC:NARRow?

Align the narrow LC prefilter. (200 kHz to 1.2 MHz)

The query performs the alignment and returns a zero if the alignment is successful.

Remarks: A valid service password needs to be entered prior to sending the command.

Front Panel

Access: **System, Alignments, Align Subsystem, IF**

Align the Wide LC Prefilter

:CALibration:PFILter:LC:WIDE

:CALibration:PFILter:LC:WIDE?

Align the wide LC prefilter. (1.2 MHz to 7.5 MHz)

The query performs the alignment and returns a zero if the alignment is successful.

Remarks: A valid service password needs to be entered prior to sending the command.

Front Panel

Access: **System, Diagnostics**

Align the Narrow Crystal Prefilter

:CALibration:PFILter:XTAL:NARRow

:CALibration:PFILter:XTAL:NARRow?

Align the narrow crystal prefilter. (2.5 kHz to 20 kHz)

The query performs the alignment and returns a zero if the alignment is successful.

Remarks: A valid service password needs to be entered prior to sending the command.

Front Panel

Access: Enter service password and press **System, Diagnostics**

Align the Wide Crystal Prefilter

:CALibration:PFILter:XTAL:WIDE

CALibration Subsystem

:CALibration:PFILter:XTAL:WIDE?

Align the wide crystal prefilter. (20 kHz to 200 kHz)

The query performs the alignment and returns a zero if the alignment is successful.

Remarks: A valid service password needs to be entered prior to sending the command.

Front Panel

Access: Enter service password and press **System, Diagnostics**

Adjust the Level of the 321.4 MHz Alignment Signal

:CALibration:REF321

:CALibration:REF321?

Calculate the curve coefficients for setting the level of the 321.4 MHz alignment signal.

Remarks: A valid service password needs to be entered prior to sending the command.

Front Panel

Access: **System, Diagnostics**

50 MHz Reference Alignment Signal

Process	Process Step Description	Command
Both	Attach a 50 MHz signal to the RF input.	
Automatic	Does the entire procedure	CAL:REF50[:DOIT]
Interactive	Enter the interactive mode	CAL:REF50:ENTer
Interactive	Tell the instrument what the external signal's power is. (approx. -25 dBm)	CAL:REF50:AMPL
Interactive	Proceed with the adjustment phase.	CAL:REF50:ANOW
Interactive	Exit from the interactive mode.	CAL:REF50:EXIT
Query	Return the last alignment value of the absolute level of the 50 MHz cal signal.	CAL:REF50:LAST:ALEVel?
Query	Return the last alignment value of the ALC DAC.	CAL:REF50:LAST:ALCDac?

External Signal Power for Internal 50 MHz Amplitude Reference Alignment

`:CALibration:REF50:AMPL <power>`

`:CALibration:REF50:AMPL?`

You must set this value equal to the actual amplitude of the external 50 MHz amplitude reference signal applied to the RF INPUT connector. This is used for aligning the 50 MHz amplitude reference with CAL:REF50.

Preset

and *RST: -25.00 dBm

Range: -30 to -20 dBm

Default Unit: dBm

Remarks: You must be in the Service mode to use this command. Use INSTRument:SElect.

A valid service password needs to be entered prior to sending this command.

Front Panel

Access: System, Alignments, Align subsystem, Align 50 MHz Reference

Internal 50 MHz Amplitude Reference Alignment Control

`:CALibration:REF50:ANOW`

Immediately does the automatic alignment of the internal 50 MHz amplitude reference oscillator. This command is used with the interactive mode of the 50 MHz alignment, i.e. CAL:REF50:ENTer.

Remarks: You must be in the Service mode to use this command. Use INSTRument:SElect.

A valid service password needs to be entered prior to sending this command.

Front Panel

Access: System, Alignments, Align subsystem, Align 50 MHz Reference

Internal 50 MHz Amplitude Reference Alignment Control

`:CALibration:REF50[:DOIT]`

`:CALibration:REF50[:DOIT]?`

Does automatic alignment of the internal 50 MHz amplitude reference

oscillator. You do this by setting an external source to -25.00 dBm and using a power meter to measure the exact value. Then use CAL:REF50:AMPL to input the source amplitude, measured on the power meter. Finally, connect the source to the instrument RF INPUT port and run the adjustment.

Remarks: You must be in the Service mode to use this command.
Use INSTRument:SElect.

A valid service password needs to be entered prior to sending this command

Front Panel

Access: System, Alignments, Align subsystem, Align 50 MHz Reference

Enter Interactive Mode for Internal 50 MHz Amplitude Reference Alignment

:CALibration:REF50:ENTER

Turns on the interactive mode for alignment of the internal 50 MHz amplitude reference signal. Use CAL:REF50:ANOW to do the alignment and CAL:REF50:EXIT to exit the interactive mode.

Remarks: You must be in the Service mode to use this command.
Use INSTRument:SElect.

A valid service password needs to be entered prior to sending this command.

Front Panel

Access: System, Alignments, Align subsystem, Align 50 MHz Reference

Exit Interactive Mode for Internal 50 MHz Amplitude Reference Alignment

:CALibration:REF50:EXIT

Turns off the interactive mode for alignment of the internal 50 MHz amplitude reference signal. Use CAL:REF50:ENTER to turn the mode on and CAL:REF50:ANOW to do the alignment immediately.

Remarks: You must be in the Service mode to use this command.
Use INSTRument:SElect.

A valid service password needs to be entered prior to sending the command.

Front Panel

Access: System, Alignments, Align subsystem, Align 50 MHz

Reference

Query the Absolute Level for the 50 MHz Amplitude Reference

`:CALibration:REF50:LAST:ALEVEL?`

Query returns the last value of the absolute level of the 50 MHz reference alignment.

Remarks: You must be in the Service mode to use this command. Use INSTRUMENT:SElect.

A valid service password needs to be entered prior to sending this command.

Front Panel

Access: **System, Alignments, Align subsystem, Align 50 MHz Reference**

Query the ALC DAC Value for the 50 MHz Amplitude Reference

`:CALibration:REF50:LAST:ALCDac?`

Query returns the last value of the ALC DAC of the 50 MHz reference alignment.

Remarks: You must be in the Service mode to use this command. Use INSTRUMENT:SElect.

A valid service password needs to be entered prior to sending this command.

Front Panel

Access: **System, Alignments, Align subsystem, Align 50 MHz Reference**

Select Time Corrections

`:CALibration:TCORrections AUTO|ON|OFF`

Controls time corrections used to compensate for the complex (magnitude and phase) response of the analog and digital IF hardware. When only scalar (magnitude) FFT flatness is required, time corrections take more CPU cycles and so are less efficient than frequency corrections. For demod or other time-based (not FFT) measurements, only time corrections can improve the flatness that results from imperfect IF hardware. When the time correction functionality is set to Auto (the default), the individual measurements activate the corrections when they are needed.

NOTE

Turning time corrections on or off effects all measurements. Time corrections should be left in Auto unless you have specific reasons for forcing them on or off.

Always return time corrections to Auto.

Factory Preset: AUTO

Front Panel

Access: **System, Alignments, Time Corr**

Align the Trigger Delay

`:CALibration:TRIGger:DElay`

`:CALibration:TRIGger:DElay?`

Align any trigger delays needed. One place that this alignment is used is for the even second clock functionality in cdmaOne mode. This same alignment is run as part of the CAL:ALL routine.

The query performs the alignment and returns a zero if the alignment is successful.

Front Panel

Access: **System, Alignments, Align subsystem, Align 50 MHz Reference**

Align the Trigger Interpolator

`:CALibration:TRIGger:INTErpolator`

`:CALibration:TRIGger:INTErpolator?`

Align the partial sample trigger interpolator. This same alignment is run as part of the CAL:ALL routine.

The query performs the alignment and returns a zero if the alignment is successful.

Front Panel

Access: **System, Alignments, Align subsystem, Align 50 MHz Reference**

CONFigure Subsystem

The CONFigure commands are used with several other commands to control the measurement process. The full set of commands are described in the section “[MEASure Group of Commands](#)” on page 193.

Selecting measurements with the CONFigure/FETCH/MEASure/READ commands sets the instrument state to the defaults for that measurement and to make a single measurement. Other commands are available for each measurement to allow you to change: settings, view, limits, etc. Refer to:

SENSe:<measurement>, SENSe:CHANnel, SENSe:CORRection,
SENSe:DEFaults, SENSe:DEViation, SENSe:FREQuency,
SENSe:PACKet, SENSe:POWer, SENSe:RADio, SENSe:SYNC

CALCulate:<measurement>, CALCulate:CLIMits

DISPlay:<measurement>

TRIGger

The INITiate[:IMMediate] or INITiate:REStart commands will initiate the taking of measurement data without resetting any of the measurement settings that you have changed from their defaults.

Configure the Selected Measurement

:CONFigure:<measurement>

A CONFigure command must specify the desired measurement. It will set the instrument settings for that measurement's standard defaults, but should not initiate the taking of data. The available measurements are described in the MEASure subsystem.

NOTE

NOTE

If CONFigure initiates the taking of data, the data should be ignored. Other SCPI commands can be processed immediately after sending CONFigure. You do not need to wait for the CONF command to complete this 'false' data acquisition.

Configure Query

:CONFigure?

The CONFigure query returns the name of the current measurement.

CONFigure Subsystem

DIAGnostic Subsystem

Hardware diagnostic commands.

These commands are not supported. They are for internal use only.

DIAGnostic Subsystem

DISPlay Subsystem

The DISPlay controls the selection and presentation of textual, graphical, and TRACe information. Within a DISPlay, information may be separated into individual WINDows.

Adjacent Channel Power - View Selection

```
:DISPlay:ACP:VIEW BGRaph|SPECTrum
```

```
:DISPlay:ACP:VIEW?
```

Select the adjacent channel power measurement display of bar graph or spectrum.

You may want to disable the spectrum trace data part of the measurement so you can increase the speed of the rest of the measurement display. Use `SENSe:ACP:SPECTrum:ENABLE` to turn on or off the spectrum trace. (Basic and cdmaOne modes only)

Factory Preset: Bar Graph (BGRaph)

Remarks: For E4406A you must be in the Basic, cdmaOne, cdma2000, W-CDMA, NADC or PDC mode to use this command. Use `INSTrument:SElect` to set the mode.

For PSA you must be in the cdmaOne, cdma2000, W-CDMA, NADC or PDC mode to use this command. Use `INSTrument:SElect` to set the mode.

Front Panel

Access: **ACP, View/Trace**

Code Domain - Base Code Length

```
:DISPlay:CDPower:BCLength 64|128
```

```
:DISPlay:CDPower:BCLength?
```

Set the base code length.

Factory Preset: 64

Remarks: You must be in the cdma2000 mode to use this command. Use `INSTrument:SElect` to set the mode.

Code Domain - View Selection

```
:DISPlay:CDPower:VIEW PGRaph|IQPGraph
```

DISPlay Subsystem

:DISPlay:CDPower:VIEW?

Select one of the code domain measurement result views as follows:

PGRaph (Power Graph & Metrics) - provides a combination view of the code domain power graph and the summary data.

IQPGraph (I/Q Polar & Power Graph) - provides a combination view of the code doamin power graph, symbol I/Q polar graph, and chip power vs. time graph.

Factory Preset: PGRaph (Power Graph & Metrics)

Remarks: You must be in the 1xEV-DO mode to use this command. Use INSTRument:SElect to set the mode.

Front Panel

Access: **Code Domain, View/Trace**

Code Domain - View Selection

:DISPlay:CDPower:VIEW PGRaph | SEVM | QUAD | DBITs

:DISPlay:CDPower:VIEW?

Set the view of the code domain measurement.

Power Graph (PGRaph) - provides a combination view of the code domain power graph and the summary data.

Symbol EVM (SEVM) - provides a combination view of the magnitude error, phase error, EVM graphs, and the summary data.

Quad-view (QUAD) - provides a combination view of the graphs for the code domain power, symbol power, I/Q symbol polar vector, and the summary data.

Demod bits (DBITs) - provides a combination view of the graphs for the code domain power and symbol power, and the I/Q demodulated bit stream data for the symbol power slots selected by the measurement interval and measurement offset.

Factory Preset: PGRaph (Power Graph & Metrics)

Remarks: You must be in the W-CDMA mode to use this command. Use INSTRument:SElect to set the mode.

Front Panel

Access: **Code Domain, View/Trace**

Turn the Display On/Off

:DISPlay:ENABle OFF | ON | 0 | 1

:DISPlay:ENABle?

Controls the display. For E4406A, if enable is set to off, the display will appear to “freeze” in its current state. Measurements may run faster since the instrument doesn’t have to update the display after every data acquisition. There is often no need to update the display information when using remote operation. Turning the display off will also extend its life and reduce EMI. An instrument preset will turn the display back on.

Factory Preset: On

Remarks: The following key presses will turn display enable back on:

1. If in local, press any key
2. If in remote, press the local (system) key
3. If in local lockout (SYST:KLOCK), no key press will work

Front Panel

Access

(for E4406A): **System, Disp Updates**

EDGE PVT - Limit Mask On/Off

:DISPlay:EPVTime:LIMit:MASK OFF|ON|0|1

:DISPlay:EPVTime:LIMit:MASK?

Turns on/off the display of the limit mask lines. It also disables the limit checking.

Factory Preset: On

Remarks: You must be in EDGE (w/GSM) to use this command. Use INSTRument:SElect to set the mode.

Front Panel

Access: **Display**, with EPVT measurement selected

Error Vector Magnitude - View Selection

:DISPlay:EVMagnitude:VIEW POLar|CONStIn|QUAD

:DISPlay:EVMagnitude:VIEW?

Select the view of EVM measurement

Factory Preset: POLar

Remarks: You must be in the NADC or PDC mode to use this command. Use INSTRument:SElect to set the mode.

QPSK Error Vector Magnitude - View Selection

:DISPlay:EVMQpsk:VIEW POLar |ERRor

:DISPlay:EVMQpsk:VIEW?

Set the view of QPSK EVM measurement.

POLar: provides a combination view of the I/Q measured polar constellation graph and the summary data.

ERRor: provides a combination view of the EVM vs. symbol, phase error vs. symbol, magnitude error vs.symbol graphs, and the summary data.

Factory Preset: POLar

Remarks: You must be in the W-CDMA mode to use this command. Use INSTRument:SElect to set the mode.

Select Display Format

:DISPlay:FORMat:TILE

Selects the viewing format that displays multiple windows of the current measurement data simultaneously. Use DISP:FORM:ZOOM to return the display to a single window.

Remarks: For PSA you must be in the Basic, cdmaOne,cdma2000, 1xEV-DO, W-CDMA, GSM (w/EDGE), NADC, or PDC mode to use this command. Use INSTRument:SElect to set the mode

Front Panel

Access: **Zoom** (toggles between Tile and Zoom)

Select Display Format

:DISPlay:FORMat:ZOOM

Selects the viewing format that displays only one window of the current measurement data (the current active window). Use DISP:FORM:TILE to return the display to multiple windows.

Remarks: For PSA you must be in the Basic, cdmaOne,cdma2000, 1xEV-DO, W-CDMA, GSM (w/EDGE), NADC, or PDC mode to use this command. Use INSTRument:SElect to set the mode

Front Panel

Access: **Zoom** (toggles between Tile and Zoom)

PVT - Limit Mask Display

:DISPlay:PVTime:LIMit:MASK OFF|ON|0|1

:DISPlay:PVTime:LIMit:MASK?

Turns on/off the display function of the limit mask lines. It also controls the limit checking function.

See also [:SENS]:PVT:LIM:MASK.

Factory Preset: ON

Remarks: You must be in GSM, EDGE, 1xEV-DO or W-CDMA mode to use this command. Use INSTRument:SElect to set the mode.

Front Panel

Access: **Power vs Time, Display**

PVT - Burst Search Threshold Line

:DISPlay:PVTime:BURSt:STHReshold OFF|ON|0|1

:DISPlay:PVTime:BURSt:STHReshold?

Turn on or off the display function of the burst search threshold line.

ON - display the burst search threshold line.

OFF - disable to display the burst search threshold line.

Factory Preset: ON

Remarks: You must be in the 1xEV-DO mode to use this command. Use INSTRument:SElect to set the mode.

Front Panel

Access: **Power vs Time, Display**

PVT - View Selection

:DISPlay:PVTime:VIEW ALL|BOTH|A|B|C|D|E

:DISPlay:PVTime:VIEW?

Select one of the power versus time measurement result views as follows:

ALL - displays the whole burst waveform throughout the all regions.

BOTH - displays both the rising and falling edges expanded in the horizontal scale.

A - display only the A region in the full horizontal scale.

B - display only the B region in the full horizontal scale.

DISPlay Subsystem

C - display only the C region in the full horizontal scale.

D - display only the D region in the full horizontal scale.

E - display only the E region in the full horizontal scale.

Factory Preset: ALL

Remarks: You must be in the 1xEV-DO or W-CDMA mode to use this command. Use INSTRUMENT:SELEct to set the mode.

Front Panel

Access: **Power vs Time, View/Trace**

Modulation Accuracy (Rho) - View Selection

1xEV-DO (Forward link)

:DISPlay:RHO:VIEW ERROR | POLar | QUAD | TABLE | TPHase

1xEV-DO (Reverse link)

:DISPlay:RHO:VIEW ERROR | POLar | TABLE

CDMA2000

:DISPlay:RHO:VIEW ERROR | POLar

W-CDMA

:DISPlay:RHO:VIEW ERROR | POLar | PGRaph | TABLE

:DISPlay:RHO:VIEW?

Select one of the modulation accuracy (rho) measurement result views as follows:

ERRor (IQ Error: Quad View) - provides a combination view of the EVM vs. symbol, phase error vs. symbol, magnitude error vs. symbol graphs, and the summary data for each channel type specified.

POLar (IQ Measured Polar Graph) - provides a combination view of the I/Q measured polar constellation graph and the summary data for each channel type specified.

QUAD (IQ Measured: Quad-view) - provides a combination view of an I/Q power vs. chip, I/Q vector absolute power vs. chip, I/Q polar graphs, and the summary data for each channel type specified.

PGRaph (Code Domain Power) - provides a combination view of Code Domain Power Graph, I/Q measured polar constellation and Active Channel Table.

TABLE (Result Metrics) - provides a measurement result on Rho, EVM, and other metrics of each channel type specified in tabular form.

TPHase (Power Timing and Phase) - provides a measurement result on power levels, timing, phase, and code domain errors in tabular form for each active

code.

Factory Preset: POLar

Remarks: You must be in the 1xEV-DO, W-CDMA, or cdma2000 mode to use this command. Use INSTRument:SElect to set the mode.

Front Panel

Access: **Mod Accuracy, View/Trace**

Spectrum - Y-Axis Scale/Div

```
:DISPlay:SPECTrum[n]:WINDow[m]:TRACe:Y[:SCALE]:PDIVision  
<power>
```

```
:DISPlay:SPECTrum[n]:WINDow[m]:TRACe:Y[:SCALE]:PDIVision?
```

Sets the amplitude reference level for the y-axis.

n – selects the view, the default is Spectrum.

m – selects the window within the view. The default is 1.

— n=1, m=1 Spectrum

— n=1, m=2 I/Q Waveform

— n=1, m=2 I and Q Waveform (Basic, W-CDMA, cdma2000)

— n=1, m=3 numeric data (Service mode, E4406A only)

— n=1, m=4 RF envelope (Service mode, E4406A only)

— n=2, m=1 I Waveform (Option B7C, E4406A only)

— n=2, m=2 Q Waveform (Option B7C, E4406A only)

— n=3, m=1 I/Q Polar (Basic, W-CDMA, cdma2000)

— n=4, m=1 Linear Spectrum (Basic, W-CDMA, cdma2000)

Factory Preset: 10 dB per division, for Spectrum

100 mV per division, for I/Q Waveform

Range: 0.1 dB to 20 dB per division, for Spectrum

1 nV to 20 V per division, for I/Q Waveform

Default Unit: 10 dB per division, for Spectrum

Remarks: May affect input attenuator setting.

For E4406A to use this command, the appropriate mode should be selected with INSTRument:SElect.

For PSA you must be in Basic, cdmaOne, cdma2000, 1xEV-DO, W-CDMA GSM w/EDGE, NADC, or PDC mode. Set the mode

DISPlay Subsystem

with INSTRument:SElect.

Front Panel

Access: When in Spectrum measurement: **Amplitude Y Scale, Scale/Div.**

History: For PSA:
Added revision A.02.00

For E4406A:
Modified revision A.05.00

Spectrum - Y-Axis Reference Level

:DISPlay:SPECTrum[n]:WINDow[m]:TRACe:Y[:SCALE]:RLEVel
<power>

:DISPlay:SPECTrum[n]:WINDow[m]:TRACe:Y[:SCALE]:RLEVel?

Sets the amplitude reference level for the y-axis.

n, selects the view, the default is RF envelope.

— n=1, m=1 Spectrum

— n=1, m=2 I/Q Waveform

— n=1, m=2 I and Q Waveform (Basic, W-CDMA, cdma2000)

— n=1, m=3 numeric data (Service mode, E4406A only)

— n=1, m=4 RF envelope (Service mode, E4406A only)

— n=2, m=1 I Waveform (Option B7C, E4406A only)

— n=2, m=2 Q Waveform (Option B7C, E4406A only)

— n=3, m=1 I/Q Polar (Basic, W-CDMA, cdma2000)

— n=4, m=1 Linear Spectrum (Basic, W-CDMA, cdma2000)

m – selects the window within the view. The default is 1.

Factory Preset: 0 dBm, for Spectrum

Range: –250 to 250 dBm, for Spectrum

Default Unit: dBm, for Spectrum

Remarks: May affect input attenuator setting.

For E4406A to use this command, the appropriate mode should be selected with INSTRument:SElect.

For PSA you must be in Basic, cdmaOne, cdma2000, 1xEV-DO, W-CDMA GSM w/EDGE, NADC, or PDC mode. Set the mode with INSTRument:SElect.

Front Panel

Access: When in Spectrum measurement: **Amplitude Y Scale, Ref Level**

History: For PSA:
Added revision A.02.00

For E4406A:
Modified revision A.05.00

Terminal Code Domain Measurement - View Selection

:DISPlay:TCDPower:VIEW PGRaph|QUAD|SEVM|DBITs

:DISPlay:TCDPower:VIEW?

Select one of the terminal code domain measurement result views as follows:

PGRaph - provides a combination view of the code domain power graph and the summary data.

QUAD - provides a combination view of graphics for code domain power, symbol power, I/Q symbol polar vector, and the summary data for the specified code channel.

SEVM - provides a combination view of the magnitude error, phase error, EVM graphs, and summary data for the specified code channel.

DBITs - provides a combination view of the graphics for the code domain power and symbol power, and the I/Q demodulated bit stream data for symbol power slots selected by measurement interval and measurement offset.

Factory Preset: PGRaph

Remarks: You must be in the 1xEV-DO mode to use this command. Use INSTRument:SElect to set the mode.

Front Panel

Access: **Mod Accuracy, View/Trace**

Turn a Trace Display On/Off

:DISPlay:TRACe[n][:STATe] OFF|ON|0|1

:DISPlay:TRACe[n][:STATe]?

Controls whether the specified trace is visible or not.

n is a sub-opcode that is valid for the current measurement. See the [“MEASure Group of Commands” on page 193](#) for more information about sub-opcodes.

Factory Preset: On

Range: The valid traces and their sub-opcodes are dependent upon the selected measurement. See the following table.

DISPlay Subsystem

The trace name assignment is independent of the window number.

Remarks: For E4406A to use this command, the appropriate mode should be selected with INSTRUMENT:SElect.

Remarks: For PSA you must be in the Basic, cdmaOne,cdma2000, 1xEV-DO, W-CDMA, GSM (w/EDGE), NADC, or PDC mode to use this command. Use INSTRUMENT:SElect to set the mode

Front Panel

Access: **Display, Display Traces**

Measurement	Available Traces	Markers Available?
ACP - adjacent channel power (Basic, cdmaOne, cdma2000, W-CDMA, iDEN (E4406A only), NADC, PDC modes)	no traces $(n=0)^a$ for I/Q points	no markers
BER - bit error rate (iDEN mode, E4406A only)	no traces $(n=0)^a$ for I/Q data	no markers
CDPower - code domain power (cdmaOne mode)	POWer $(n=2)^a$ TIMing $(n=3)^a$ PHASe $(n=4)^a$ $(n=0)^a$ for I/Q points	yes
CDPower - code domain power (cdma2000, 1xEV-DO, W-CDMA modes)	$(n=0)^a$ for I/Q raw data CDPower $(n=2)^a$ EVM $(n=5)^a$ MERRor $(n=6)^a$ PERRor $(n=7)^a$ SPOWer $(n=9)^a$ CPOWer $(n=10)^a$	yes
CHPower - channel power (Basic, cdmaOne, cdma2000, 1xEV-DO, W-CDMA modes)	SPECTrum $(n=2)^a$ $(n=0)^a$ for I/Q raw data	no markers
CSPur - spurs close (cdmaOne mode)	SPECTrum $(n=2)^a$ ULIMit $(n=3)^a$ $(n=0)^a$ for I/Q points	yes

Measurement	Available Traces	Markers Available?
EEVM - EDGE error vector magnitude (EDGE mode)	EVMError ($n=2$) ^a MERRor ($n=3$) ^a PERRor ($n=4$) ^a ($n=0$) ^a for I/Q points	yes
EORFspectr - EDGE output RF spectrum (EDGE mode)	RFEMod ($n=2$) ^a RFESwitching ($n=3$) ^a SPEMod ($n=4$) ^a LIMMod ($n=5$) ^a ($n=0$) ^a for I/Q points	yes, only for a single offset yes, only for multiple offsets
EPVTime - EDGE power versus time (EDGE mode)	RFENvelope ($n=2$) ^a UMASk ($n=3$) ^a LMASk ($n=4$) ^a ($n=0$) ^a for I/Q points	yes
ETSPur - EDGE transmit band spurs (EDGE mode)	SPECtrum ($n=2$) ^a ULIMit ($n=3$) ^a ($n=0$) ^a for I/Q points	yes
EVM - error vector magnitude (NADC, PDC modes)	EVM ($n=2$) ^a MERRor ($n=3$) ^a PERRor ($n=4$) ^a ($n=0$) ^a for I/Q points	yes
EVMQpsk - QPSK error vector magnitude (cdma2000, 1xEV-DO, W-CDMA modes)	EVM ($n=2$) ^a MERRor ($n=3$) ^a PERRor ($n=4$) ^a ($n=0$) ^a for I/Q raw data	yes
IM - intermodulation (cdma2000, 1xEV-DO, W-CDMA modes)	SPECtrum ($n=2$) ^a ($n=0$) ^a for I/Q raw data	yes
MCPower - multi-carrier power (W-CDMA mode)	no traces ($n=0$) ^a for I/Q points	no markers

DISPlay Subsystem

Measurement	Available Traces	Markers Available?
OBW - occupied bandwidth (cdmaOne, cdma2000, 1xEV-DO, iDEN (E4406A only), PDC, W-CDMA modes)	no traces $(n=0)^a$ for I/Q raw data	no markers
ORFSpectrum - output RF spectrum (GSM, EDGE mode)	RFEMod $(n=2)^a$ RFESwitching $(n=3)^a$ SPEMod $(n=4)^a$ LIMMod $(n=5)^a$ $(n=0)^a$ for I/Q points	yes, only for a single offset yes, only for multiple offsets
PFERror - phase and frequency error (GSM, EDGE mode)	PERRor $(n=2)^a$ PFERror $(n=3)^a$ RFENvelope $(n=4)^a$ $(n=0)^a$ for I/Q points	yes
PStatistic - power statistics CCDF (Basic, cdma2000, 1xEV-DO, W-CDMA modes)	MEASured $(n=2)^a$ GAUSian $(n=3)^a$ REFerence $(n=4)^a$ $(n=0)^a$ for I/Q points	yes
PVTime - power versus time (GSM, EDGE, 1xEV-DO, Service (E4406A only) modes)	$(n=0)^a$ for I/Q raw data RFENvelope $(n=2)^a$ UMASK $(n=3)^a$ LMASK $(n=4)^a$	yes
RHO - modulation quality (cdmaOne, cdma2000, W-CDMA mode)	$(n=0)^a$ for I/Q raw data EVM $(n=2)^a$ MERRor $(n=3)^a$ PERRor $(n=4)^a$ $(n=5)^a$ for I/Q corrected trace data	yes

Measurement	Available Traces	Markers Available?
RHO - modulation quality (1xEV-DO mode)	(n=0) ^a for I/Q raw data (n=1) ^a for various summary results EVM (n=2) ^a MERRor (n=3) ^a PERRor (n=4) ^a (n=5) ^a for I/Q corrected trace data	yes
SEMask - spectrum emissions mask (cdma2000, 1xEV-DO, W-CDMA mode)	SPEctrum (n=2) ^a (n=0) ^a for I/Q raw data	yes
TSPur - transmit band spurs (GSM, EDGE mode)	SPEctrum (n=2) ^a ULIMit (n=3) ^a (n=0) ^a for I/Q points	yes
TXPower - transmit power (GSM, EDGE mode)	RFENvelope (n=2) ^a IQ (n=8) ^a (n=0) ^a for I/Q points	yes
SPEctrum - (frequency domain) (all modes)	RFENvelope (n=2) ^a for Service mode (E4406A only) IQ (n=3) ^a SPEctrum (n=4) ^a ASPEctrum (n=7) ^a (n=0) ^a for I/Q raw data	yes
WAVEform - (time domain) (all modes)	RFENvelope (n=2) ^a (also for Signal Envelope trace) IQ (n=5) ^a (n=0) ^a for I/Q raw data	yes

- a. The *n* number indicates the sub-opcode that corresponds to this trace. Detailed descriptions of the trace data can be found in the MEASure subsystem documentation by looking up the sub-opcode for the appropriate measurement.

Terminal Modulation Accuracy Measurement– View Selection

DISPlay:TRHO:VIEW POLar | ERRor | TABle

DISPlay:TRHO:VIEW?

Select view to display TRHO data.

- POLar - Provides a combination view of the I/Q Measured Polar display and summary data
- ERRor - Provides a combination view of the magnitude error, phase error, EVM Graphs, and summary data
- TABle - Provides a result table in text display

Factory Preset: POLar

Remarks: You must be in the 1xEV-DO mode to use this command. Use INSTRument:SElect to set the mode.

Waveform - Y-Axis Scale/Div

**:DISPlay:WAVeform[n]:WINDow[m]:TRACe:Y[:SCALE]:PDIVision
<power>**

:DISPlay:WAVeform[n]:WINDow[m]:TRACe:Y[:SCALE]:PDIVision?

Sets the scale per division for the y-axis.

n, selects the view, the default is RF envelope.

n=1, m=1 RF envelope

n=2, m=1 I/Q Waveform

n=2, m=1 I and Q Waveform (Option B7C, E4406A only)

n=4, m=1 I/Q Polar (Basic, W-CDMA, cdma2000)

n=5, m=1 Linear Envelope (Option B7C, E4406A only)

m, selects the window within the view. The default is 1.

Factory Preset: 10 dBm, for RF envelope

Range: .1 dB to 20 dB, for RF envelope

Default Unit: dBm, for RF envelope

Remarks: May affect input attenuator setting.

For E4406A to use this command, the appropriate mode should be selected with INSTRument:SElect.

For PSA you must be in Basic, cdmaOne, cdma2000, 1xEV-DO, W-CDMA GSM w/EDGE, NADC, or PDC mode. Set the mode with INSTRument:SElect.

Front Panel

Access: When in Waveform measurement: **Amplitude Y Scale, Scale/Div.**

History: For PSA:
Added revision A.02.00

For E4406A:
Modified revision A.05.00

Waveform - Y-Axis Reference Level

:DISPlay:WAVEform[n]:WINDow[m]:TRACe:Y[:SCALE]:RLEVEL
<power>

:DISPlay:WAVEform[n]:WINDow[m]:TRACe:Y[:SCALE]:RLEVEL?

Sets the amplitude reference level for the y-axis.

n, selects the view, the default is RF envelope.

n=1, m=1 RF envelope

n=2, m=1 I/Q Waveform

n=2, m=1 I and Q Waveform (Option B7C, E4406A only)

n=4, m=1 I/Q Polar (Basic, W-CDMA, cdma2000)

n=5, m=1 Linear Envelope (Option B7C, E4406A only)

m, selects the window within the view. The default is 1.

Factory Preset: 0 dBm, for RF envelope

Range: -250 to 250 dBm, for RF envelope

Default Unit: dBm, for RF envelope

Remarks: May affect input attenuator setting.

For E4406A to use this command, the appropriate mode should be selected with INSTRument:SElect.

For PSA you must be in Basic, cdmaOne, cdma2000, 1xEV-DO, W-CDMA GSM w/EDGE, NADC, or PDC mode. Set the mode with INSTRument:SElect.

Front Panel

Access: When in Waveform measurement: **Amplitude Y Scale, Ref Level**

History: For PSA:

DISPlay Subsystem

Added revision A.02.00

For E4406A:

Modified revision A.05.00

Window Focus Move Control

:DISPlay:WINDow[:SElect] <number>

:DISPlay:WINDow[:SElect]?

Move window focus to specified window (1 to 4). Window selection depends on currently available views.

Factory Preset: 1

Range: Window dependant

Remarks: You must be in the W-CDMA mode to use this command. Use INSTRument:SElect to set the mode.

X-Scale Commands

The following X-scale operations can be used to graphical display (window) for all measurements except Spectrum and Waveform.

X-Axis Couple Control

:DISPlay:WINDow[1] | 2 | 3 | 4:TRACe:X[:SCALe]:COUPlE 0 | 1 | Off | On

:DISPlay:WINDow[1] | 2 | 3 | 4:TRACe:X[:SCALe]:COUPlE?

Turn the couple mode for the x-axis On or Off.

Factory Preset: Window dependant

Remarks: You must be in the W-CDMA mode to use this command. Use INSTRument:SElect to set the mode.

X-Axis Scale/Div

:DISPlay:WINDow[1] | 2 | 3 | 4:TRACe:X[:SCALe]:PDIVision <number>

:DISPlay:WINDow[1] | 2 | 3 | 4:TRACe:X[:SCALe]:PDIVision?

Set the scale per division for the x-axis.

Factory Preset: Window dependant

Range: Window dependant

Remarks: You must be in the W-CDMA mode to use this command. Use

INSTRument:SELect to set the mode.

X-Axis Reference Level

:DISPlay:WINDow[1] | 2 | 3 | 4:TRACe:X[:SCALe]:RLEVel <number>

:DISPlay:WINDow[1] | 2 | 3 | 4:TRACe:X[:SCALe]:RLEVel?

Set the reference level for the x-axis.

Factory Preset: Window dependant

Range: Window dependant

Remarks: You must be in the W-CDMA mode to use this command. Use INSTRument:SELect to set the mode.

X-Axis Reference Position

:DISPlay:WINDow[1] | 2 | 3 | 4:TRACe:X[:SCALe]:RPOSITION <number 0.0 to 10.0>

:DISPlay:WINDow[1] | 2 | 3 | 4:TRACe:X[:SCALe]:RPOSITION?

Set the point on the x-axis to be used as the reference position.

0.0: Left, 5.0: Center, 10.0:Right

Factory Preset: Window dependant

Range: 0.0 to 10.0

Remarks: You must be in the W-CDMA mode to use this command. Use INSTRument:SELect to set the mode.

Y-Scale Commands

The following Y-scale operations can be used to graphical display (window) for all measurements except Spectrum and Waveform.

Y-Axis Couple Control

:DISPlay:WINDow[1] | 2 | 3 | 4:TRACe:Y[:SCALe]:COUple 0 | 1 | Off | On

:DISPlay:WINDow[1] | 2 | 3 | 4:TRACe:Y[:SCALe]:COUple?

Turn the couple mode for the y-axis On or Off.

Factory Preset: Window dependant

Remarks: You must be in the W-CDMA mode to use this command. Use INSTRument:SELect to set the mode.

DISPlay Subsystem

Y-Axis Scale/Div

:DISPlay:WINDow[1] | 2 | 3 | 4:TRACe:Y[:SCALE]:PDIVision <number>

:DISPlay:WINDow[1] | 2 | 3 | 4:TRACe:Y[:SCALE]:PDIVision?

Set the scale per division for the y-axis.

Factory Preset: Window dependant

Range: Window dependant

Remarks: You must be in the W-CDMA mode to use this command. Use INSTRument:SElect to set the mode.

Y-Axis Reference Level

:DISPlay:WINDow[1] | 2 | 3 | 4:TRACe:Y[:SCALE]:RLEVel <number>

:DISPlay:WINDow[1] | 2 | 3 | 4:TRACe:Y[:SCALE]:RLEVel?

Set the amplitude reference level for the y-axis.

Factory Preset: Window dependant

Range: Window dependant

Remarks: You must be in the W-CDMA mode to use this command. Use INSTRument:SElect to set the mode.

Y-Axis Reference Position

**:DISPlay:WINDow[1] | 2 | 3 | 4:TRACe:Y[:SCALE]:RPOSition <number
0.0 to 10.0>**

:DISPlay:WINDow[1] | 2 | 3 | 4:TRACe:Y[:SCALE]:RPOSition?

Set the point on the y-axis to be used as the reference position.

0.0: Bottom, 5.0: Center, 10.0:Top

Factory Preset: Window dependant

Range: 0.0 to 10.0

Remarks: You must be in the W-CDMA mode to use this command. Use INSTRument:SElect to set the mode.

FETCh Subsystem

The FETCh? queries are used with several other commands to control the measurement process. These commands are described in the section on the “MEASure Group of Commands” on page 193. These commands apply only to measurements found in the MEASURE menu.

This command puts selected data from the most recent measurement into the output buffer (new data is initiated/measured). Use FETCh if you have already made a good measurement and you want to look at several types of data (different [n] values) from the single measurement. FETCh saves you the time of re-making the measurement. You can only fetch results from the measurement that is currently active.

If you need to make a new measurement, use the READ command, which is equivalent to an INITiate[:IMMEDIATE] followed by a FETCh.

:FETCh <meas>? will return valid data only when the measurement is in one of the following states:

- idle
- initiated
- paused

Fetch the Current Measurement Results

:FETCh:<measurement>[n]?

A FETCh? command must specify the desired measurement. It will return the valid results that are currently available, but will not initiate the taking of any new data. You can only fetch results from the measurement that is currently selected. The code number n selects the kind of results that will be returned. The available measurements and data results are described in the “MEASure Group of Commands” on page 193.

FEtCh Subsystem

FORMat Subsystem

The FORMat subsystem sets a data format for transferring numeric and array information.

Byte Order

:FORMat:BORDER NORMAl | SWAPped

:FORMat:BORDER?

Selects the binary data byte order for numeric data transfer. In normal mode the most significant byte is sent first. In swapped mode the least significant byte is first. (PCs use the swapped order.) Binary data byte order functionality does not apply to ASCII.

Factory Preset: Normal

Remarks: You must be in the Basic, cdma2000, 1xEV-DO, W-CDMA, GSM (w/EDGE), NADC, or PDC mode to use this command. Use INSTRument:SElect to set the mode.

Numeric Data Format

PSA/VSA Basic, cdmaOne, cdma2000, 1xEV-DO, W-CDMA, GSM, EDGE, NADC, PDC modes:

:FORMat[:DATA] ASCii | REAL, 32 | REAL, 64

:FORMat[:DATA]?

VSA/PSA application modes: This command controls the format of data input/output, that is any data transfer across any remote port. The REAL and ASCII formats will format data in the current display units. The format of state data cannot be changed. It is always in a machine readable format only.

ASCII - Amplitude values are in ASCII, in amplitude units, separated by commas. ASCII format requires more memory than the binary formats. Therefore, handling large amounts of this type of data, will take more time and storage space.

Real,32 or Real,64 - Binary 32-bit (or 64-bit) real values in amplitude unit, in a definite length block. Transfers of real data are done in a binary block format.

A definite length block of data starts with an ASCII header that begins with # and indicates how many additional data points are following in the block. Suppose the header is #512320.

FORMat Subsystem

- The first digit in the header (5) tells you how many additional digits/bytes there are in the header.
- The 12320 means 12 thousand, 3 hundred, 20 data bytes follow the header.
- Divide this number of bytes by your selected data format bytes/point, either 8 (for real 64), or 4 (for real 32). In this example, if you are using real 64 then there are 1540 points in the block.

Example: FORM REAL,64

Factory Preset: ASCII

HCOPY Subsystem

The HCOpy subsystem controls the setup of printing to an external device.

Screen Printout Destination

`:HCOpy:DESTination FPANel|PRINter`

`:HCOpy:DESTination?`

This command was created to support backward compatibility to early instrument functionality. It is used to specify whether the hardcopy printout goes to the printer or to a destination that is specified from the front panel key **Print Setup, Print To File|Printer**.

Example: HCOP:DEST printer

Factory Preset: Front panel. This parameter is persistent, which means it retains the value previously selected even through a power cycle.

History: Revision A.04.00 and later

Front Panel

Access: **Print Setup, Print To**

Custom Printer Color Capability

`:HCOpy:DEvIce:COLor NO|YES`

`:HCOpy:DEvIce:COLor?`

Specifies whether the printer is color capable, not whether you want to print in color. HCOpy:DEvIce:TYPE CUSTOM must be selected.

Example: HCOP:DEV:COLOR YES

Factory Preset: Yes. This parameter is persistent, which means it retains the value previously selected even through a power cycle.

History: Revision A.04.00 and later

Front Panel

Access: **Print Setup, (select Print To:Printer and Printer Type:Custom), Define Custom**

Custom Printer Language

`:HCOPY:DEVIce:LANGUage PCL3|PCL5`

`:HCOPY:DEVIce:LANGUage?`

Specifies the type of printer control language that your custom printer uses. HCOPY:DEVICE:TYPE CUSTOM must be selected.

Example: HCOP:DEV:LANG pcl3

Factory Preset: PCL3. This parameter is persistent, which means it retains the value previously selected even through a power cycle.

History: Revision A.04.00 and later

Front Panel

Access: **Print Setup**, (select Print To:Printer and Printer Type:Custom), **Define Custom**

Printer Type

`:HCOPY:DEVIce[:TYPE] CUSTOm|NONE`

`:HCOPY:DEVIce[:TYPE]?`

Set up the printer by selecting the type of printer.

CUSTOm - allows you to configure a custom printer if your printer cannot be auto-configured. Use other HCOPY:DEVICE commands to specify some of the characteristics of your custom printer. The color and language must be defined for your custom printer. You must select the custom printer type to print hardcopy output.

NONE - tells the instrument that there is no hard copy (printer) device available.

Factory Preset: NONE - This parameter is persistent, which means that it retains the setting previously selected, even through a power cycle.

History: Revision A.04.00 and later

Front Panel

Access: **Print Setup**, (select Print To:Printer), **Printer Type**

Color Hard Copy

`:HCOPY:IMAGe:COLOr[:STATE] OFF|ON|0|1`

`:HCOPY:IMAGe:COLOr[:STATE]?`

Selects between color and monochrome mode for hard copy output. You must set HCOP:DEV:COLOR YES before using this command.

Factory Preset: On. This parameter is persistent, which means that it retains the setting previously selected, even through a power cycle.

Remarks: Revision A.04.00 and later

Front Panel

Access: **Print Setup**, (select Print To:Printer), **Color**

Print a Hard Copy

`:HCOPY[:IMMEDIATE]`

The entire screen image is output to the printer at the parallel port.

Front Panel

Access: **Print**

Form Feed the Print Item

`:HCOPY:ITEM:FFeed[:IMMEDIATE]`

Sends the printer a command to form feed. No form feed will occur unless the printer has only printed one image of a multi-image printout.

History: Revision A.04.00 and later

Front Panel

Access: **Print Setup**, (select Print To:Printer), **More, Eject Page**

Page Orientation

`:HCOPY:PAGE:ORIENTATION LANDscape|PORTRait`

`:HCOPY:PAGE:ORIENTATION?`

Specifies the orientation of the print image.

NOTE

Landscape mode is not presently supported for PCL-3 printers.

Factory Preset: Portrait. This parameter is persistent, which means that it retains the setting previously selected, even through a power cycle.

History: Revision A.04.00 and later

Front Panel

Access: **Print Setup**, (select Print To:Printer), **Orientation**

Number of Screen Images Printed on a Page

:HCOPY:PAGE:PRINTs 1|2

:HCOPY:PAGE:PRINTs?

Sets the number of display images that should be printed on one sheet of paper, before a form feed is sent.

Factory Preset: 1. This parameter is persistent, which means that it retains the setting previously selected, even through a power cycle.

History: Revision A.04.00 and later

Remarks: This can only be set to 2 if the paper orientation is portrait.

Front Panel

Access: **Print Setup**, (select Print To:Printer), **Prints/Page**

Reprint the Last Image

:HCOPY:REPrint[:IMMediate]

Reprint the most recently printed image.

Example: HCOP:REPR

History: Revision A.04.00 and later

Front Panel

Access: **Print Setup** with Print To:Printer selected

Screen Dump Query

:HCOPY:SDUMp:DATA? [GIF]|BMP|WMF

The query returns the current screen image as a file. If the optional file type is not specified it returns GIF type graphic data. The orientation is always portrait and the image is always in color.

The data is formatted as block data where the block of data starts with an ASCII header that indicates how many additional binary data bytes are following in the block. (e.g. #DNNN<binary data>) The binary data is the actual graphics file. To process the block of data you would:

- Read the first header byte #. The # tells you to read the next digit (D). That digit tells you how many additional digits there are in the header. (In the above example D=3.)
- Then read the next D (that is, 3) bytes. The digits NNN tell you the number of bytes of data there are following the header.
- Those final data bytes are the screen image in the requested format. They can be saved as a separate file with a .gif, .bmp or .wmf suffix to use in other applications.

Factory Preset: GIF

History: Firmware revision A.03.28 and later, changed A.04.00

Screen Dump Image Inverting

`:HCOPY:SDUMP:IMAGE NORMAL|INVERT`

`:HCOPY:SDUMP:IMAGE?`

Controls the trace background color when using the `HCOPY:SDUMP:DATA?` query.

Normal, is black trace background

Invert, is white trace background

Factory Preset: Invert

History: Revision A.04.00 and later

Screen Dump to a Printer

`:HCOPY:SDUMP[:IMMEDIATE]`

The entire screen image is output to the printer (remote interface). The image is always inverted.

History: Revision A.04.00 and later

INITiate Subsystem

The INITiate subsystem is used to initiate a trigger for a measurement. They only initiate measurements from the MEASURE front panel key or the “MEASure Group of Commands” on page 193. Refer to the TRIGger and ABORt subsystems for related commands.

Take New Data Acquisition for Selected Measurement

:INITiate:<measurement>

For PSA this command is not available for measurements in the instrument modes: Spectrum Analysis, or Phase Noise.

This command initiates a trigger cycle for the measurement specified, but does not return data. The available measurement names are described in the MEASure subsystem..

If your selected measurement is not currently active it will change to the measurement in your INIT:<meas> command and initiate a trigger cycle.

Example: INIT:ACP

Continuous or Single Measurements

:INITiate:CONTinuous OFF|ON|0|1

:INITiate:CONTinuous?

Selects whether a trigger is continuously initiated or not. Each trigger initiates a single, complete, measurement operation.

When set to ON another trigger cycle is initiated at the completion of each measurement.

When set to OFF, the trigger system remains in the “idle” state until an INITiate[:IMMediate] command is received. On receiving the INITiate[:IMMediate] command, it will go through a single trigger/measurement cycle, and then return to the “idle” state.

Example: INIT:CONT ON

Factory Preset: On

*RST: Off (recommended for remote operation)

Front Panel

Access: **Meas Control, Measure Cont Single**

Take New Data Acquisitions

:INITiate[:IMMediate]

The instrument must be in the single measurement mode. If INIT:CONT is ON, then the command is ignored. The desired measurement must be selected and waiting. The command causes the system to exit the “waiting” state and go to the “initiated” state.

The trigger system is initiated and completes one full trigger cycle. It returns to the “waiting” state on completion of the trigger cycle. Depending upon the measurement and the number of averages, there may be multiple data acquisitions, with multiple trigger events, for one full trigger cycle.

This command triggers the instrument, if external triggering is the type of trigger event selected. Otherwise, the command is ignored. Use the TRIGger[:SEQuence]:SOURce EXT command to select the external trigger.

Example: INIT:IMM

Remarks: See also the *TRG command and the TRIGger subsystem.

Front Panel

Access: **Meas Control, Measure Cont Single**

Restart the Measurement

:INITiate:REStart

This command applies to measurements found in the MEASURE menu. It restarts the current measurement from the “idle” state regardless of its current operating state. It is equivalent to:

INITiate[:IMMediate]

ABORt (for continuous measurement mode)

Example: INIT:REST

Front Panel

Access: **Restart**

or

Meas Control, Restart

INPut Subsystem

The INPut subsystem controls the characteristics of all the instrument input ports.

Baseband I/Q - Select Input Impedance

```
:INPut:IMPedance:IQ U50ohm|B600ohm|U1Mohm|B1Mohm
```

```
:INPut:IMPedance:IQ?
```

Selects the characteristic input impedance when input port is set to I or Q. This is the impedance value as well as the unbalanced (U) or balanced (B) impedance mode.

1000000 or 1E6 sets input impedance to 1 M ohm.

Factory Preset
and *RST: U1Mohm

Remarks: You must be in the Basic, W-CDMA, cdma2000 mode to use this command. Use INSTRument:SElect to set the mode.

History: Added revision A.05.00

Baseband I/Q - Select Input Impedance Reference

```
:INPut:IMPedance:REFerence <integer>
```

```
:INPut:IMPedance:REFerence?
```

Sets the value of the input impedance reference when input port is set to I or Q.

1000000 or 1E6 sets input impedance to 1 M ohm.

Range: 1 to 10,000,000.

Default Units: ohm

Remarks: You must be in the Basic, W-CDMA, cdma2000 mode to use this command. Use INSTRument:SElect to set the mode.

History: Added revision A.05.00

Baseband I/Q - Activate IQ Alignment

```
:INPut:IQ:ALIGn OFF|ON|0|1
```

INPut Subsystem

:INPut:IQ:ALIGn?

Activates or deactivates IQ alignment.

Factory Preset
and *RST: Off

Remarks: You must be in the Basic, W-CDMA, cdma2000 mode to use this command. Use INSTRUMENT:SElect to set the mode.

History: Added revision A.05.00

Baseband I/Q - I Input DC Offset

:INPut:OFFSet:I <level>

:INPut:OFFSet:I?

Sets adjustment to compensate for I voltage bias on signals when the I input port is selected.

Factory Preset
and *RST: 0

Range: -2.5, 0, or +2.5 volts

Default Units: V

Remarks: You must be in the Basic, W-CDMA, cdma2000 mode to use this command. Use INSTRUMENT:SElect to set the mode.

History: Added revision A.05.00

Baseband I/Q - Q Input DC Offset

:INPut:OFFSet:Q <level>

:INPut:OFFSet:Q?

Sets adjustment to compensate Q voltage bias on signals when the Q input port is selected.

Factory Preset
and *RST: 0

Range: -2.5, 0, or +2.5 volts

Default Units: V

Remarks: You must be in the Basic, W-CDMA, cdma2000 mode to use this command. Use INSTRUMENT:SElect to set the mode.

History: Added revision A.05.00

INPut Subsystem

INSTrument Subsystem

This subsystem includes commands for querying and selecting instrument measurement (personality option) modes.

Catalog Query

For E4406A, `:INSTrument:CATalog[:FULL]?`

Returns a comma separated list of strings which contains the names of all the installed applications. These names can only be used with the `INST:SElect` command.

For E4406A if the optional keyword `FULL` is specified, each name is immediately followed by its associated instrument number. These instrument numbers can only be used with the `INST:NSElect` command.

Example:

(E4406A) `INST:CAT:FULL?`

Query response:

`"BASIC"8,"GSM"3,"CDMA"4,"SERVICE"1`

Select Application by Number

`:INSTrument:NSElect <integer>`

`:INSTrument:NSElect?`

Select the measurement mode by its instrument number. The actual available choices depends upon which applications are installed in the instrument. For E4406A these instrument numbers can be obtained with `INST:CATalog:FULL?`

- 1 = SA
- 1 = SERVICE (E4406A)
- 3 = GSM (E4406A)
- 4 = CDMA (cdmaOne)
- 5 = NADC
- 6 = PDC
- 8 = BASIC
- 9 = WCDMA (3GPP)
- 10 = CDMA2K (cdma2000)
- 11 = IDEN (E4406A)
- 13 = EDGE GSM
- 15 = CMDA1XEV (1xEV-D0)

NOTE

If you are using the SCPI status registers and the analyzer mode is

INSTrument Subsystem

changed, the status bits should be read, and any errors resolved, prior to switching modes. Error conditions that exist prior to switching modes cannot be detected using the condition registers after the mode change. This is true unless they recur after the mode change, although transitions of these conditions can be detected using the event registers.

Changing modes resets all SCPI status registers and mask registers to their power-on defaults. Hence, any event or condition register masks must be re-established after a mode change. Also note that the power up status bit is set by any mode change, since that is the default state after power up.

Example: INST:NSEL 4

Factory Preset: Persistent state with factory default of 8
(E4406A, BASIC)

Range: 1 to x, where x depends upon which applications are
 installed.

Front Panel

Access: **MODE**

Select Application

VSA E4406A:

```
:INSTrument[:SElect]
BASIC|SERVICE|CDMA|CDMA2K|GSM|EDGEgSM|IDEN|NADC|PDC|
WCDMA|CDMA1XEV
```

```
:INSTrument[:SElect]?
```

Select the measurement mode. The actual available choices depend upon which modes (measurement applications) are installed in the instrument. A list of the valid choices is returned with the INST:CAT? query.

Once an instrument mode is selected, only the commands that are valid for that mode can be executed.

- 1 = SERVICE (E4406A)
- 3 = GSM (E4406A)
- 4 = CDMA (cdmaOne)
- 5 = NADC
- 6 = PDC
- 8 = BASIC
- 9 = WCDMA (3GPP)
- 10 = CDMA2K (cdma2000)
- 11 = IDEN (E4406A)
- 13 = EDGEgSM
- 15 = CDMA1XEV (1xEV-DO)

229 = MAN (Modulation Analysis)
231 = LINK (89600 VSA Link software)

NOTE

If you are using the status bits and the analyzer mode is changed, the status bits should be read, and any errors resolved, prior to switching modes. Error conditions that exist prior to switching modes cannot be detected using the condition registers after the mode change. This is true unless they recur after the mode change, although transitions of these conditions can be detected using the event registers.

Changing modes resets all SCPI status registers and mask registers to their power-on defaults. Hence, any event or condition register masks must be re-established after a mode change. Also note that the power up status bit is set by any mode change, since that is the default state after power up.

Factory Preset:
(E4406A) Persistent state with factory default of Basic mode.

Front Panel
Access: **MODE**

INSTrument Subsystem

MEASure Group of Commands

This group includes the CONFigure, FETCh, MEASure, and READ commands that are used to make measurements and return results. The different commands can be used to provide fine control of the overall measurement process, like changing measurement parameters from their default settings. Most measurements should be done in single measurement mode, rather than measuring continuously.

The SCPI default for the format of any data output is ASCII. The format can be changed to binary with FORMat:DATA which transports faster over the bus.

Command Interactions: MEASure, CONFigure, FETCh, INITiate and READ

Figure 0-3 Measurement Group of Commands

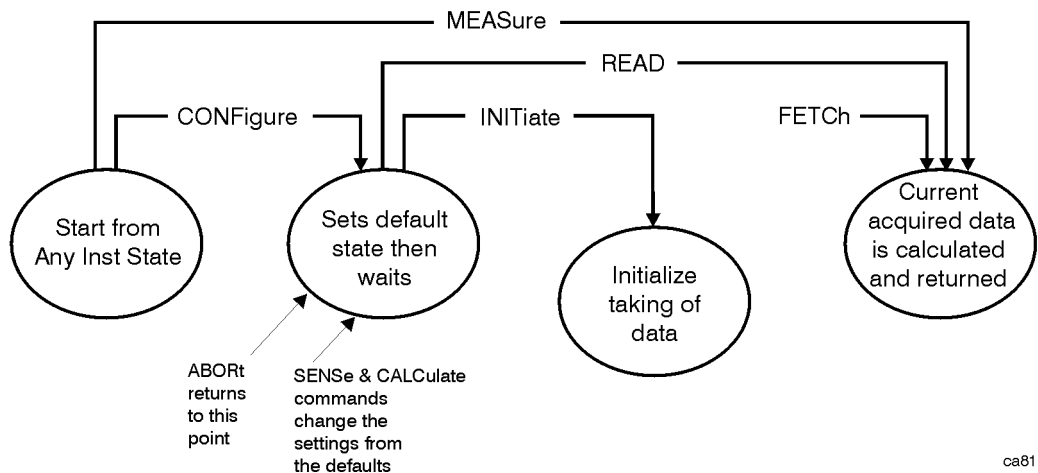

Measure Commands:

:MEASure:<measurement>[n]?

This is a fast single-command way to make a measurement using the factory default instrument settings. These are the settings and units that conform to the Mode Setup settings (e.g. radio standard) that you have currently selected.

- Stops the current measurement (if any) and sets up the instrument for the specified measurement using the factory defaults
- Initiates the data acquisition for the measurement
- Blocks other SCPI communication, waiting until the measurement is complete before returning results.
- After the data is valid it returns the scalar results, or the trace data, for the specified measurement. The type of data returned may be defined by an [n] value that is sent with the command.

The scalar measurement results will be returned if the optional [n] value is not included, or is set to 1. If the [n] value is set to a value other than 1, the selected trace data results will be returned. See each command for details of what types of scalar results or trace data results are available.

ASCII is the default format for the data output. The binary data formats should be used for handling large blocks of data since they are smaller and faster than the ASCII format. Refer to the FORMat:DATA command for more information.

If you need to change some of the measurement parameters from the factory default settings you can set up the measurement with the CONFigure command. Use the commands in the SENSE:<measurement> and CALCulate:<measurement> subsystems to change the settings. Then you can use the READ? command to initiate the measurement and query the results. See [Figure 0-3](#).

If you need to repeatedly make a given measurement with settings other than the factory defaults, you can use the commands in the SENSE:<measurement> and CALCulate:<measurement> subsystems to set up the measurement. Then use the READ? command to initiate the measurement and query results.

Measurement settings persist if you initiate a different measurement and then return to a previous one. Use READ:<measurement>? if you want to use those persistent settings. If you want to go back to the default settings, use MEASure:<measurement>?.

Configure Commands:

:CONFigure: <measurement>

This command stops the current measurement (if any) and sets up the instrument for the specified measurement using the factory default instrument settings. It sets the instrument to single measurement mode but should not initiate the taking of measurement data unless INIT:CONTinuous is ON. After you change any measurement settings, the READ command can be used to initiate a measurement without changing the settings back to their defaults.

NOTE

In instruments with firmware older than A.05.00 CONFigure initiates the taking of data. The data should be ignored. Other SCPI commands can be processed immediately after sending CONFigure. You do not need to wait for the CONF command to complete this 'false' data acquisition.

The CONFigure? query returns the current measurement name.

Fetch Commands:

:FETCh: <measurement>[n]?

This command puts selected data from the most recent measurement into the output buffer. Use FETCh if you have already made a good measurement and you want to return several types of data (different [n] values, e.g. both scalars and trace data) from a single measurement. FETCh saves you the time of re-making the measurement. You can only FETCh results from the measurement that is currently active, it will not change to a different measurement.

If you need to get new measurement data, use the READ command, which is equivalent to an INITiate followed by a FETCh.

The scalar measurement results will be returned if the optional [n] value is not included, or is set to 1. If the [n] value is set to a value other than 1, the selected trace data results will be returned. See each command for details of what types of scalar results or trace data results are available. The binary data formats should be used for handling large blocks of data since they are smaller and transfer faster than the ASCII format. (FORMat:DATA)

FETCh may be used to return results other than those specified with the original READ or MEASure command that you sent.

INITiate Commands:**:INITiate:** <measurement>

This command is not available for measurements in all the instrument modes:

- Initiates a trigger cycle for the specified measurement, but does not output any data. You must then use the FETCh<meas> command to return data. If a measurement other than the current one is specified, the instrument will switch to that measurement and then initiate it.

For example, suppose you have previously initiated the ACP measurement, but now you are running the channel power measurement. If you send INIT:ACP? it will change from channel power to ACP and will initiate an ACP measurement.

- Does not change any of the measurement settings. For example, if you have previously started the ACP measurement and you send INIT:ACP? it will initiate a new ACP measurement using the same instrument settings as the last time ACP was run.
- If your selected measurement is currently active (in the idle state) it triggers the measurement, assuming the trigger conditions are met. Then it completes one trigger cycle. Depending upon the measurement and the number of averages, there may be multiple data acquisitions, with multiple trigger events, for one full trigger cycle. It also holds off additional commands on GPIB until the acquisition is complete.

READ Commands:**:READ:** <measurement> [n]?

- Does not preset the measurement to the factory default settings. For example, if you have previously initiated the ACP measurement and you send READ:ACP? it will initiate a new measurement using the same instrument settings.
- Initiates the measurement and puts valid data into the output buffer. If a measurement other than the current one is specified, the instrument will switch to that measurement before it initiates the measurement and returns results.

For example, suppose you have previously initiated the ACP measurement, but now you are running the channel power measurement. Then you send READ:ACP? It will change from channel power back to ACP and, using the previous ACP settings, will initiate the measurement and return results.

- Blocks other SCPI communication, waiting until the measurement is complete before returning the results

If the optional [n] value is not included, or is set to 1, the scalar measurement results will be returned. If the [n] value is set to a value other than 1, the selected trace data results will be returned. See each command for details of what types of scalar results or trace data results are available. The binary data formats should be used when handling large blocks of data since they are smaller and faster than the ASCII format. (FORMat:DATA)

Adjacent Channel Power Ratio (ACP) Measurement

For E4406A this measures the total rms power in the specified channel and in 5 offset channels. You must be in Basic, cdmaOne, cdma2000, W-CDMA, iDEN, NADC or PDC mode to use these commands. Use INSTRument:SElect to set the mode.

The general functionality of CONFigure, FETCh, MEASure, and READ are described at the beginning of this section. See the SENSE:ACP commands for more measurement related commands.

```
:CONFigure:ACP
:INITiate:ACP
:FETCh:ACP[n]?
:READ:ACP[n]?
:MEASure:ACP[n]?
```

For Basic mode, a channel frequency and power level can be defined in the command statement to override the default standard setting. A comma must precede the power value as a place holder for the frequency, when no frequency is sent.

History: E4406A:
Added to Basic mode, version A.03.00 or later

Front Panel

Access: **Measure, ACP or ACPR**

After the measurement is selected, press **Restore Meas Defaults** to restore factory defaults.

Measurement Results Available

Measurement Type	n	Results Returned
	0	Returns unprocessed I/Q trace data, as a series of trace point values, in volts. The I values are listed first in each pair, using the 0 through even-indexed values. The Q values are the odd-indexed values.

Measurement Type	n	Results Returned
	n=1 (or not specified) NADC and PDC mode	Returns 22 scalar results, in the following order: 1. Center frequency – absolute power (dBm) 2. Center frequency – absolute power (W) 3. Negative offset frequency (1) – relative power (dB) 4. Negative offset frequency (1) – absolute power (dBm) 5. Positive offset frequency (1) – relative power (dB) 6. Positive offset frequency (1) – absolute power (dBm) . . . 1. Positive offset frequency (5) – relative power (dB) 2. Positive offset frequency (5) – absolute power (dBm)
	n=1 (or not specified) iDEN mode E4406A	Returns 13 scalar results, in the following order: 1. Center frequency – relative power (dB) 2. Center frequency – absolute power (dBm) 3. Lower offset frequency – relative power (dB) 4. Lower offset freq– absolute power (dBm) 5. Upper offset frequency – relative power (dB) 6. Upper offset frequency – absolute power (dBm) 7. Total power (dBm) 8. Offset frequency (Hz) 9. Reference BW (Hz) 10. Offset BW (Hz) 11. Carrier/center frequency (Hz) 12. Frequency span (Hz) 13. Average count
Total power reference	n=1 (or not specified) Basic, cdmaOne, cdma2000, W-CDMA mode	Returns 24 scalar results, in the following order: 1. Center frequency - relative power (dB) 2. Center frequency - absolute power (dBm) 3. Center frequency - relative power (dB) (same as value 1) 4. Center frequency - absolute power (dBm) (same as value 2) 5. Negative offset frequency (1) - relative power (dB), 6. Negative offset frequency (1) - absolute power (dBm) 7. Positive offset frequency (1) - relative power (dB) 8. Positive offset frequency (1) - absolute power (dBm) . . . 1. Positive offset frequency (5) - relative power (dB) 2. Positive offset frequency (5) - absolute power (dBm) <hr/> NOTE Center frequency relative power is relative to the center frequency absolute power and therefore, is always equal to 0.00 dB. <hr/>

Measurement Type	n	Results Returned
Power spectral density reference	n=1 (or not specified) Basic, cdmaOne, cdma2000, W-CDMA mode	<p>Returns 24 scalar results, in the following order:</p> <ol style="list-style-type: none"> 1. Center frequency - relative power (dB) 2. Center frequency - absolute power (dBm/Hz) 3. Center frequency - relative power (dB) (same as value 1) 4. Center frequency - absolute power (dBm/Hz) (same as value 2) 5. Negative offset frequency (1) - relative power (dB) 6. Negative offset frequency (1) - absolute power (dBm/Hz) 7. Positive offset frequency (1) - relative power (dB) 8. Positive offset frequency (1) - absolute power (dBm/Hz) <p style="text-align: center;">. . .</p> <ol style="list-style-type: none"> 1. Positive offset frequency (5) - relative power (dB) 2. Positive offset frequency (5) - absolute power (dBm/Hz) <hr/> <p>NOTE Center frequency relative power is relative to the center frequency absolute power and therefore, is always equal to 0.00 dB.</p>
	2 NADC and PDC mode	<p>Returns 10 scalar values of the pass/fail (0=passed, or 1=failed) results determined by testing the absolute power of the offset frequencies:</p> <ol style="list-style-type: none"> 1. Negative offset frequency (1) absolute power 2. Positive offset frequency (1) absolute power <p style="text-align: center;">. . .</p> <ol style="list-style-type: none"> 1. Negative offset frequency (5) absolute power 2. Positive offset frequency (5) absolute power
	2 iDEN mode	<p>Returns 3 scalar values of the histogram absolute power trace:</p> <ol style="list-style-type: none"> 1. Lower offset frequency – absolute power 2. Reference frequency – absolute power 3. Upper offset frequency – absolute power

Measurement Type	n	Results Returned
Total power reference	2 Basic, cdmaOne, cdma2000, W-CDMA mode	Returns 11 scalar values (in dBm) corresponding to the total power histogram display. The values are returned in ascending frequency order: <ol style="list-style-type: none"> 1. Negative offset frequency (5) 2. Negative offset frequency (4) 3. Negative offset frequency (3) ... 1. Center frequency 2. Positive offset frequency (1) 3. Positive offset frequency (2) ... 1. Positive offset frequency (5)
	3 NADC and PDC mode	Returns 10 scalar values of the pass/fail (0=passed, or 1=failed) results determined by testing the relative power of the offset frequencies: <ol style="list-style-type: none"> 1. Negative offset frequency (1) relative power 2. Positive offset frequency (1) relative power ... 1. Negative offset frequency (5) relative power 2. Positive offset frequency (5) relative power
	3 iDEN mode E4406A	Returns 3 scalar values of the histogram relative power trace: <ol style="list-style-type: none"> 1. Lower offset frequency – relative power 2. Reference frequency – relative power 3. Upper offset frequency – relative power
Power spectral density reference	3 Basic, cdmaOne, cdma2000, W-CDMA mode	Returns 11 scalar values (in dBm/Hz) corresponding to the power spectral density histogram display. The values are returned in ascending frequency order: <ol style="list-style-type: none"> 1. Negative offset frequency (5) 2. Negative offset frequency (4) ... 1. Center frequency 2. Positive offset frequency (1) ... 1. Positive offset frequency (5)

Measurement Type	n	Results Returned
	4 NADC and PDC mode	Returns the frequency-domain spectrum trace (data array) for the entire frequency range being measured. In order to return spectrum data, the ACP display must be in the spectrum view and you must not turn off the spectrum trace.
	4 iDEN mode E4406A	Returns 4 absolute power values for the reference and offset channels. <ol style="list-style-type: none"> 1. Reference channel – absolute power 2. Reference channel – absolute power (duplicate of above) 3. Lower offset channel – absolute power 4. Upper offset channel – absolute power
(For cdma2000 and W-CDMA the data is only available with spectrum display selected)	4 Basic, cdmaOne, cdma2000, W-CDMA mode	Returns the frequency-domain spectrum trace data for the entire frequency range being measured. With the spectrum view selected (DISPlay:ACP:VIEW SPECTrum) and the spectrum trace on (SENSe:ACP:SPECTrum:ENABLE): <ul style="list-style-type: none"> • In FFT mode (SENSe:ACP:SWEep:TYPE FFT) the number of trace points returned are 343 (cdma2000) or 1715 (W-CDMA). This is with the default span of 5 MHz (cdma2000) or 25 MHz (W-CDMA). The number of points also varies if another offset frequency is set. • In sweep mode (SENSe:ACP:SWEep:TYPE SWEep), the number of trace points returned is 601 (for cdma2000 or W-CDMA) for any span. With bar graph display selected, one point of -999.0 will be returned.
	5 iDEN mode E4406A	Returns 4 relative power values for the reference and offset channels: <ol style="list-style-type: none"> 1. Reference channel – relative power 2. Reference channel – relative power (duplicate of above) 3. Lower offset channel – relative power 4. Upper offset channel – relative power
Total power reference	5 Basic, cdmaOne, cdma2000, W-CDMA mode	Returns 12 scalar values (in dBm) of the absolute power of the center and the offset frequencies: <ol style="list-style-type: none"> 1. Upper adjacent chan center frequency 2. Lower adjacent chan center frequency 3. Negative offset frequency (1) 4. Positive offset frequency (1) ... 1. Negative offset frequency (5) 2. Positive offset frequency (5)

Measurement Type	n	Results Returned
Power spectral density reference	5 Basic, cdmaOne, cdma2000, W-CDMA mode	Returns 12 scalar values (in dBm/Hz) of the absolute power of the center and the offset frequencies: <ol style="list-style-type: none"> 1. Upper adjacent chan center frequency 2. Lower adjacent chan center frequency 3. Negative offset frequency (1) 4. Positive offset frequency (1) <p style="text-align: center;">. . .</p> <ol style="list-style-type: none"> 1. Negative offset frequency (5) 2. Positive offset frequency (5)
	6 iDEN mode E4406A	Returns 4 pass/fail test results for the absolute power of the reference and offset channels: <ol style="list-style-type: none"> 1. Reference channel absolute power pass/fail 2. Reference channel absolute power pass/fail (duplicate of above) 3. Lower offset channel absolute power pass/fail 4. Upper offset channel absolute power pass/fail
Total power reference	6 Basic, cdmaOne, cdma2000, W-CDMA mode	Returns 12 scalar values (total power in dB) of the power relative to the carrier at the center and the offset frequencies: <ol style="list-style-type: none"> 1. Upper adjacent chan center frequency 2. Lower adjacent chan center frequency 3. Negative offset frequency (1) 4. Positive offset frequency (1) 5. Negative offset frequency (5) <p style="text-align: center;">. . .</p> <ol style="list-style-type: none"> 1. Negative offset frequency (5) 2. Positive offset frequency (5)
Power spectral density reference	6 Basic, cdmaOne, cdma2000, W-CDMA mode	Returns 12 scalar values (power spectral density in dB) of the power relative to the carrier at the center and offset frequencies: <ol style="list-style-type: none"> 1. Upper adjacent chan center frequency 2. Lower adjacent chan center frequency 3. Negative offset frequency (1) 4. Positive offset frequency (1) <p style="text-align: center;">. . .</p> <ol style="list-style-type: none"> 1. Negative offset frequency (5) 2. Positive offset frequency (5)

Measurement Type	n	Results Returned
	7 iDEN mode E4406A	Returns 4 pass/fail test results for the relative power of the reference and offset channels: <ol style="list-style-type: none"> 1. Reference channel relative power pass/fail 2. Reference channel relative power pass/fail (duplicate of above) 3. Lower offset channel relative power pass/fail 4. Upper offset channel relative power pass/fail
Total power reference	7 Basic, cdmaOne, cdma2000, W-CDMA mode	Returns 12 scalar values of the pass/fail (0=passed, or 1=failed) results determined by testing the absolute power limit of the center and offset frequencies (measured as total power in dB): <ol style="list-style-type: none"> 1. Upper adjacent chan center frequency 2. Lower adjacent chan center frequency 3. Negative offset frequency (1) 4. Positive offset frequency (1) <p style="text-align: center;">. . .</p> <ol style="list-style-type: none"> 1. Negative offset frequency (5) 2. Positive offset frequency (5)
Power spectral density reference	7 Basic, cdmaOne, cdma2000, W-CDMA mode	Returns 12 scalar values of the pass/fail (0=passed, or 1=failed) results determined by testing the absolute power limit of the center and offset frequencies (measured as power spectral density in dB): <ol style="list-style-type: none"> 1. Upper adjacent chan center frequency 2. Lower adjacent chan center frequency 3. Negative offset frequency (1) 4. Positive offset frequency (1) <p style="text-align: center;">. . .</p> <ol style="list-style-type: none"> 1. Negative offset frequency (5) 2. Positive offset frequency (5)
Total power reference	8 Basic, cdmaOne, cdma2000, W-CDMA mode	Returns 12 scalar values of the pass/fail (0=passed, or 1=failed) results determined by testing the power limit relative to the center frequency (measured as total power spectral in dB): <ol style="list-style-type: none"> 1. Upper adjacent chan center frequency 2. Lower adjacent chan center frequency 3. Negative offset frequency (1) 4. Positive offset frequency (1) <p style="text-align: center;">. . .</p> <ol style="list-style-type: none"> 1. Negative offset frequency (5) 2. Positive offset frequency (5)

Measurement Type	n	Results Returned
Power spectral density reference	8 Basic, cdmaOne, cdma2000, W-CDMA mode	Returns 12 scalar values of the pass/fail (0=passed, or 1=failed) results determined by testing the power limit relative to the center frequency (measured as power spectral density in dB): <ol style="list-style-type: none">1. Upper adjacent chan center frequency2. Lower adjacent chan center frequency3. Negative offset frequency (1)4. Positive offset frequency (1) . . .1. Negative offset frequency (5)2. Positive offset frequency (5)

50 MHz Amplitude Reference Measurement

This aligns the internal 50 MHz reference signal to an external reference signal that you supply. You must be in the Service mode to use these commands. Use INSTRument:SElect to set the mode.

The general functionality of CONFigure, FETCh, MEASure, and READ are described at the beginning of this section. See the SENSE:AREference commands for more measurement related commands.

```
:CONFigure:AREference
:INITiate:AREference
:FETCh:AREference[n]?
:READ:AREference[n]?
:MEASure:AREference[n]?
```

Remarks: For auto adjustment of the internal 50 MHz amplitude reference, use CALibration:AMPLitude:REference:AADJust command after this measurement has been selected.

Front Panel

Access: **Measure, 50 MHz Amptd**

After the measurement is selected, press **Restore Meas Defaults** to restore factory defaults.

Measurement Results Available

n	Results Returned
n=1 (or not specified)	Returns 7 scalar results: <ol style="list-style-type: none"> 1. RF input average amplitude 2. 50 MHz reference oscillator average amplitude 3. Average amplitude error 4. State (for factory use only) 5. Level (for factory use only) 6. Monitored level (for factory use only) 7. Connector status (for factory use only)
2	RF input amplitude trace data.
3	50 MHz oscillator amplitude trace data
4	Amplitude error strip chart trace data

Bit Error Rate Measurement

This tests for bit errors in the demodulated signal. You must be in the IDEN mode to use these commands. Use INSTRument:SElect to set the mode.

The general functionality of CONFigure, FETCh, MEASure, and READ are described at the beginning of this section. See the SENSE:BER commands for more measurement related commands.

:CONFigure:BER

:INITiate:BER

:FETCh:BER[n]?

:READ:BER[n]?

:MEASure:BER[n]?

History: Version A.03.00 or later

Front Panel

Access: Measure, Bit Error Rate

After the measurement is selected, press **Restore Meas Defaults** to restore factory defaults.

Measurement Results Available

n	Results Returned
0	Returns unprocessed I/Q trace data, as a series of trace point values, in volts. The I values are listed first in each pair, using the 0 through even-indexed values. The Q values are the odd-indexed values.
n=1 (or not specified)	Returns these 15 scalar results in the following order: 1. Total bit error rate (BER in %) 2. Total number of bits tested 3. Total number of bits failed 4. Total number of frames tested 5. Total number of frames attempted to find 6. Current frame word found 7. Bit error rate for current word 8. Calculated center frequency error 9. Measured carrier frequency 10. Frequency span 11. Average count 12. EVM for first sub-channel 13. EVM for second sub-channel 14. EVM for third sub-channel 15. EVM for fourth sub-channel

MEASure Group of Commands

n	Results Returned
2	Returns unprocessed frame I/Q data, as a data array of trace point values, in volts.

Code Domain Power Measurement

This measures the power levels of the spread channels in RF channel(s). You must be in the cdmaOne, cdma2000, W-CDMA, or 1xEV-DO mode to use these commands. Use INSTRument:SElect to set the mode.

For 1xEV-DO, this measurement is used only for base stations (Network Access). When measuring 1xEV-DO mobile stations (Access Terminals) use Terminal Code Domain Measurements (MEAS:TCDPower) and set SENSE:RADio:DEvice to MS.

The general functionality of CONFigure, FETCh, MEASure, and READ are described at the beginning of this section. See the SENSE:CDPower commands for more measurement related commands.

:CONFigure:CDPower

:INITiate:CDPower

:FETCh:CDPower[n]?

:READ:CDPower[n]?

:MEASure:CDPower[n]?

Front Panel

Access: **Measure, Code Domain**

After the measurement is selected, press **Restore Meas Defaults** to restore factory defaults.

Measurement Results Available

n	Results Returned
0	Returns unprocessed I/Q trace data, as a series of trace point values, in volts. The I values are listed first in each pair, using the 0 through even-indexed values. The Q values are the odd-indexed values.

n	Results Returned
n=1 (or not specified) cdmaOne mode	<p>Returns the following 25 scalar results:</p> <ol style="list-style-type: none"> 1. Time offset is a floating point number with units of seconds. This is the time delay of the even second clock with respect to the start of the short code PN sequences, at offsets from the 15 zeros in the characteristic phase of the sequences. 2. Frequency error is a floating point number (in Hz) of the frequency error in the measured signal. This error is based on the linear best fit of the uncorrected measured phase. 3. Carrier feedthrough is a floating point number (in dB) of the dc offset, of I and Q, from the origin. 4. Pilot power is a floating point number with units of dB. It is the relative power of the pilot channel (Walsh code 0) with respect to the carrier power. 5. Paging power is a floating point number with units of dB. It is the relative power of the paging channel (Walsh code 1) with respect to the carrier power. 6. Sync power is a floating point number with units of dB. It is the relative power of the sync channel (Walsh code 32) with respect to the carrier power. 7. Average traffic power is a floating point number with units of dB. It is the average relative power of the active traffic channels with respect to the carrier power. Traffic channels are defined as all of the Walsh codes except Walsh 0,1,32. A traffic channel is active if its coding power is greater than the active threshold parameter which you have selected. 8. Maximum inactive traffic power is a floating point number with units of dB. It is the maximum relative power of an inactive traffic channel with respect to the carrier power. Traffic channels are defined as all of the Walsh codes except Walsh 0,1,32. A traffic channel is inactive if its coding power is less than the active threshold parameter which you have selected. 9. Average inactive traffic power is a floating point number with units of dB. It is the average relative power of the inactive traffic channels with respect to the carrier power. Traffic channels are defined as all of the Walsh codes except Walsh 0,1,32. A traffic channel is inactive if its coding power is less than the active threshold parameter which you have selected. 10. Marker Values The last 16 measurement results are the current values for all four available markers. The values are zero for any marker that is not active. <ol style="list-style-type: none"> 10. Marker 1 position (code number) 11. Marker 1 power level 12. Marker 1 time value 13. Marker 1 phase value . . . 25. Marker 4 phase value

n	Results Returned
n=1 (or not specified) cdma2000 mode	<p>Returns the following 19 scalar results:</p> <ol style="list-style-type: none"> 1. RMS symbol EVM is a floating point number (in percent) of the EVM over the entire measurement area. 2. Peak symbol EVM is a floating point number (in percent) of the peak EVM in the measurement area. 3. Symbol magnitude error is a floating point number (in percent) of the average magnitude error over the entire measurement area. 4. Symbol phase error is a floating point number (in degrees) of the average phase error over the entire measurement area. 5. Total power is a floating point number (in dBm) of the total RF power over the measurement interval. 6. Channel power is a floating point number (in dBc or dBm depending on the measurement type, see below) of the power in the entire slot, for the selected code, averaged over the measurement interval. NOTE: When measurement type = rel, then the value displayed is in units of dBc, and the relative power is calculated as the ratio of the Channel Power to the Total Power (parameter 5 above). 7. Total active power is a floating point number (in dB or dBm depending on the measurement type) of the sum of the active power. 8. Pilot power is a floating point number (in dB or dBm depending on the measurement type) of the average power of the Pilot code. 9. Sync power is a floating point number (in dB or dBm depending on the measurement type) of the average power of the Sync code. In the MS mode, the value returned is -999. 10. Maximum active traffic power is a floating point number (in dB or dBm depending on the measurement type) of the maximum average power of the active code. If no active code is detected the value returned is -999. In the MS mode, the value returned is -999. 11. Average active traffic power is a floating point number (in dB or dBm depending on the measurement type) of the average power of all the active traffic channels. If no active code is detected the value returned is -999. In the MS mode, the value returned is -999. 12. Maximum inactive traffic power is a floating point number (in dB or dBm depending on the measurement type) of the maximum average power of the inactive traffic channels. In the MS mode, the value returned is -999. 13. Average inactive traffic power is a floating point number (in dB or dBm depending on the measurement type) of the average power of the inactive traffic channels. In the MS mode, the value returned is -999. 14. Number of active channel In the MS mode, the value returned is -999.

n	Results Returned
n=1 (or not specified) cdma2000 mode (continued)	<p>15. I channel average active power is a floating point number (in dB or dBm depending on the measurement type) of the average power of the active I channels. In the BS mode, the value returned is -999.</p> <p>16. I channel maximum inactive power is a floating point number (in dB or dBm depending on the measurement type) of the maximum average power of the inactive I channels. In the BS mode, the value returned is -999.</p> <p>17. Q channel average active power is a floating point number (in dB or dBm depending on the measurement type) of the average power of the active Q channels. In the BS mode, the value returned is -999.</p> <p>18. Q channel maximum inactive power is a floating point number (in dB or dBm depending on the measurement type) of the maximum average power of the inactive Q channels. In the BS mode, the value returned is -999.</p> <p>19. Time between trigger to PN Offset is a floating point number (in μs) of the time from the trigger point to the PN Offset. In the MS mode, the value returned is -999.</p>

n	Results Returned
n=1 (or not specified) W-CDMA mode	<p>Returns the following 31 scalar results:</p> <ol style="list-style-type: none"> 1. RMS symbol EVM is a floating point number (in percent) of the EVM over the entire measurement area. 2. Peak symbol EVM is a floating point number (in percent) of the peak EVM in the measurement area. 3. Symbol magnitude error is a floating point number (in percent) of the average magnitude error over the entire measurement area. 4. Symbol phase error is a floating point number (in degrees) of the average phase error over the entire measurement area. 5. Total power is a floating point number (in dBm) of the total RF power over the measurement interval. 6. Channel power is a floating point number (in dBc or dBm depending on the measurement type, see below) of the power in the entire slot, for the selected code, averaged over the measurement interval. NOTE: When measurement type = rel, then the value displayed is in units of dBc, and the relative power is calculated as the ratio of the Channel Power to the Total Power (parameter 5 above). 7. tDPCH is a floating point number (in 256 chips) of dedicated physical channel (DPCH) delay time from the reference. (tDPCH equals T_n) 8. Total power over a slot is a floating point number (in dBm) of total RF power over the measurement interval. (SCH is excluded.) 9. Total active power is a floating point number (in dB or dBm depending on the measurement type) of the sum of the active power. (SCH is excluded.) 10. Pilot power is a floating point number (in dB or dBm depending on the measurement type) of the average power of the CPICH code relative to the total slot power. In the MS mode, the value returned is -999. (SCH is excluded.) 11. Maximum active traffic power is a floating point number (in dB or dBm depending on the measurement type) of the maximum average power of the active traffic channels. If no active code is detected the value returned is -999. In the MS mode, the value returned is -999. (SCH is excluded.) 12. Average active traffic power is a floating point number (in dB or dBm depending on the measurement type) of the average power of all the active traffic channels. If no active code is detected the value returned is -999. In the MS mode, the value returned is -999. (SCH is excluded.) 13. Maximum inactive traffic power is a floating point number (in dB or dBm depending on the measurement type) of the maximum average power of the inactive traffic channels. The slot timing is determined by Perch. In the MS mode, the value returned is -999. (SCH is excluded.)

n	Results Returned
<p>n=1 (or not specified)</p> <p>W-CDMA mode (continued)</p>	<p>14. Average inactive traffic power is a floating point number (in dB or dBm depending on the measurement type) of the average power of the inactive traffic channels. In the MS mode, the value returned is –999. (SCH is excluded.)</p> <p>15. Number of active channel In the MS mode, the value returned is –999.</p> <p>16. P-SCH is a floating point number (in dBm) of the primary synchronization channel power. In the MS mode, the value returned is –999.</p> <p>17. S-SCH is a floating point number (in dBm) of the secondary synchronization channel power. In the MS mode, the value returned is –999.</p> <p>18. DPCCH Power is a floating point number (in dB or dBm depending on the measurement type) of the average power of dedicated physical control channel (DPCCH). In the BS mode, the value returned is –999. When PRACH is measured, this returns control part power.</p> <p>19. DPCCH Beta Nominal is a floating point number of the nominal beta value of DPCCH Beta factor. In the BS mode, the value returned is –999. When PRACH is measured, this returns control part Beta nominal.</p> <p>20. DPCCH Beta Measured is a floating point number of the measured value of the DPCCH Beta factor. In the BS mode, the value returned is –999. When PRACH is measured, this returns control part Beta measured.</p> <p>21. DPDCH Beta Nominal is a floating point number of the nominal beta value of the dedicated physical data channel (DPDCH) Beta factor. In the BS mode, the value returned is –999. When PRACH is measured, this returns data part Beta nominal.</p> <p>22. DPDCH Beta 1 Measured is a floating point number of the measured value of the DPDCH (C1) Beta factor. In the BS mode, the value returned is –999. When PRACH is measured, this returns data part Beta measured.</p> <p>23. DPDCH Beta 2 Measured is a floating point number of the measured value of the DPDCH (C2) Beta factor. In the BS mode, the value returned is –999. When PRACH is measured, this returns –999.</p> <p>24. DPDCH Beta 3 Measured is a floating point number of the measured value of the DPDCH (C3) Beta factor. In the BS mode, the value returned is –999. When PRACH is measured, this returns –999.</p> <p>25. DPDCH Beta 4 Measured is a floating point number of the measured value of the DPDCH (C4) Beta factor. In the BS mode, the value returned is –999. When PRACH is measured, this returns –999.</p> <p>26. DPDCH Beta 5 Measured is a floating point number of the measured value of the DPDCH (C5) Beta factor. In the BS mode, the value returned is –999. When PRACH is measured, this returns –999.</p>

n	Results Returned
n=1 (or not specified) W-CDMA mode (continued)	<p>27. DPDCH Beta 6 Measured is a floating point number of the measured value of the DPDCH (C6) Beta factor. In the BS mode, the value returned is –999. When PRACH is measured, this returns –999.</p> <p>28. I channel average active power is a floating point number (in dB or dBm depending on the measurement type) of the average power of the active I channels. In the BS mode, the value returned is –999.</p> <p>29. I channel maximum inactive power is a floating point number (in dB or dBm depending on the measurement type) of the maximum average power of the inactive I channels. In the BS mode, the value returned is –999.</p> <p>30. Q channel average active power is a floating point number (in dB or dBm depending on the measurement type) of the average power of the active Q channels. In the BS mode, the value returned is –999.</p> <p>31. Q channel maximum inactive power is a floating point number (in dB or dBm depending on the measurement type) of the maximum average power of the inactive Q channels. In the BS mode, the value returned is –999.</p>

n	Results Returned
<p>n=1 (or not specified)</p> <p>1xEV-DO mode</p>	<p>Returns the following 18 comma-delimited scalar results, in the following order:</p> <ol style="list-style-type: none"> 1. Total power is a floating point number (in dBm) of the total RF power over the measurement interval. NOTE: The following power results are computed by the CDP measurement. The unit used in the computation, either dB or dBm, is determined by the setting of the <code>CALCulate:CDPower:TYPE</code> command. When the selection is <code>ABSolute</code>, the unit used is dBm. When the selection is <code>RELative</code>, the unit used is dB relative to Total Power (above). 2. Total active power is a floating point number (in dB or dBm depending on the measurement type) of the sum of the active powers (–999.0 when no active channel is detected). 3. Maximum active power is a floating point number (in dB or dBm depending on the measurement type) of the maximum average power of the active code (–999.0 when no active channel is detected in I/Q Combined=On mode. Always –999.0 in I/Q Combined=Off mode) 4. Average active power is a floating point number (in dB or dBm depending on the measurement type) of the average power of all the active traffic channels (–999.0 when no active channel is detected in I/Q Combined=On mode. Always –999.0 in I/Q Combined=Off mode). 5. Maximum inactive power is a floating point number (in dB or dBm depending on the measurement type) of the maximum average power of the inactive traffic channels. (–999.0 in I/Q Combined=Off mode) 6. Average inactive power is a floating point number (in dB or dBm depending on the measurement type) of the average power of the inactive traffic channels. (–999.0 in I/Q Combined=Off mode) 7. Number of active channels 8. I channel average active power is a floating point number (in dB or dBm depending on the measurement type) of the average power of the active I channels. (–999.0 when I/Q Combined=On mode or when no active channel is detected in I/Q Combined=Off mode). 9. I channel maximum inactive power is a floating point number (in dB or dBm depending on the measurement type) of the maximum average power of the inactive I channels. (–999.0 when I/Q Combined=On mode) 10. Q channel average active power is a floating point number (in dB or dBm depending on the measurement type) of the average power of the active Q channels. (–999.0 when I/Q Combined=On mode or when no active channel is detected in I/Q Combined=Off mode). 11. Q channel maximum inactive power is a floating point number (in dB or dBm depending on the measurement type) of the maximum average power of the inactive Q channels. (–999.0 when I/Q Combined=On mode)

n	Results Returned
n=1 (or not specified) 1xEV-DO mode (continued)	<p>12. Preamble Length is a floating point number (in chips).</p> <p>13. Preamble MAC Index is an integer number of MAC index.</p> <p>14. Minimum Active Power is a floating point number (in dB or dBm depending on the measurement type) of the minimum average power of the active code (–999.0 when no active channel is detected in I/Q Combined=On mode. Always –999.0 in I/Q Combined=Off mode)</p> <p>15. I channel maximum inactive power is a floating point number (in dB or dBm depending on the measurement type) of the maximum average power of the inactive I channels. (–999.0 when I/Q Combined=On mode)</p> <p>16. I channel minimum inactive power is a floating point number (in dB or dBm depending on the measurement type) of the minimum average power of the inactive I channels. (–999.0 when I/Q Combined=On mode)</p> <p>17. Q channel maximum inactive power is a floating point number (in dB or dBm depending on the measurement type) of the maximum average power of the inactive Q channels. (–999.0 when I/Q Combined=On mode)</p> <p>18. Q channel minimum inactive power is a floating point number (in dB or dBm depending on the measurement type) of the minimum average power of the inactive Q channels. (–999.0 when I/Q Combined=On mode)</p>
2 cdmaOne mode	Returns floating point numbers that are the trace data of the code domain <i>power</i> trace for all 64 Walsh codes. This series of 64 numbers represent the relative power levels (in dB) of all 64 walsh codes, with respect to the carrier power.

n	Results Returned
2 cdma2000 mode	<p>Returns a series of floating point numbers (in dB or dBm depending on the measurement type) that represents all the code domain powers.</p> <p>With a device of BTS, there are 64 or 128 numbers depending on CALCulate:CDPower:WCODE:BASE. If the active channel occupies more than the max spreading factor (64 or 128 Walsh Code length depending on CALCulate:CDPower:WCODE:BASE) the power is duplicated (CALCulate:CDPower:WCODE:BASE / active Walsh code length) times.</p> <p>1st number = 1st code power over the slot 2nd number = 2nd code power over the slot ... Nth number = Nth code power over the slot</p> <p>With a device of MS, there are 256 I/Q pairs. If the active channel occupies more than the max spreading factor (C8) the power is duplicated (active Cx / C8) times.</p> <p>1st number = 1st in-phase code power over the slot 2nd number = 1st quad-phase code power over the slot ... (2×N-1)th number = Nth in-phase code power over the slot (2×N)th number = Nth quad-phase code power over a slot</p> <p>N = the number of codes detected. The total number of codes varies because of the different symbol rates of each code.</p>
2 1xEV-DO mode	<p>Returns a series of floating point numbers (in dB or dBm depending on the measurement type) that represents all the code domain powers.</p> <p>When I/Q Combined=On, total is 16 for Data, 32 for Pilot, and 64 for MAC. If the active channel occupies more than the max spreading factor (16 for Data, 32 for Pilot, and 64 for MAC) the power is duplicated.</p> <p>1st number = 1st code power over the slot 2nd number = 2nd code power over the slot ... Nth number = Nth code power over the slot</p> <p>When I/Q Combined=Off, results are returned alternatively. Total is 16 I/Q pairs for Data, 32 for Pilot, and 64 for MAC. If the active channel occupies more than the max spreading factor (16 for Data, 32 for Pilot, and 64 for MAC) the power is duplicated.</p> <p>1st number = 1st in-phase code power over the slot 2nd number = 1st quad-phase code power over the slot ... (2×N-1)th number = Nth in-phase code power over the slot (2×N)th number = Nth quad-phase code power over a slot</p> <p>N = the number of codes detected. The total number of codes varies because of the different symbol rates of each code.</p>

n	Results Returned
2 W-CDMA.mode	<p>Returns a series of floating point numbers (in dB or dBm depending on the measurement type) that represents all the code domain powers.</p> <p>With a device of BTS, there are 512 numbers. If the active channel occupies more than the max spreading factor (7.5 ksps) the power is duplicated (active symbol rate/7.5 ksps) times.</p> <p>1st number = 1st code power over the slot 2nd number = 2nd code power over the slot ... Nth number = Nth code power over the slot</p> <p>With a device of MS, there are 256 I/Q pairs. If the active channel occupies more than the max spreading factor (15 ksps) the power is duplicated (active symbol rate / 15 ksps) times.</p> <p>1st number = 1st in-phase code power over the slot 2nd number = 1st quad-phase code power over the slot ... (2×N-1)th number = Nth in-phase code power over the slot (2×N)th number = Nth quad-phase code power over a slot</p> <p>N = the number of codes detected. The total number of codes varies because of the different symbol rates of each code.</p>
3 cdmaOne mode	<p>Returns floating point numbers that are the trace data of the code domain <i>timing</i> trace for all 64 Walsh codes. This series of 64 numbers represent the relative timing estimations (in seconds) of the codes, relative to the pilot channel. Typical values are on the order of 1 ns.</p>

n	Results Returned
3 cdma2000 mode	<p>Returns a series of floating point numbers (in symbol rate) that represent all code domain symbol rates.</p> <p>With a device of BTS, there are 64 or 128 numbers depending on CALCulate:CDPower:WCODE:BASE. If the active channel occupies more than the max spreading factor (64 or 128 Walsh code length depending on CALCulate:CDPower:WCODE:BASE) the power is duplicated (CALCulate:CDPower:WCODE:BASE / active Walsh code length) times.</p> <p>1st number = 1st code symbol rate over the slot 2nd number = 2nd code symbol rate over the slot ... Nth number = Nth code symbol rate over the slot</p> <p>With a device of MS, there are 256 I/Q pairs. If the active channel occupies more than the max spreading factor (C8) the power is duplicated (active Cx / C8) times.</p> <p>1st number = 1st in-phase code symbol rate over the slot 2nd number = 1st quad-phase code symbol rate over the slot ... (2×N-1)th number = Nth in-phase code symbol rate over the slot (2×N)th number = Nth quad-phase code symbol rate over the slot</p> <p>N = the number of codes detected. The total number of codes varies because of the different symbol rates of each code.</p>
3 1xEV-DO mode	<p>Returns a series of floating point numbers (in dB or dBm depending on the measurement type) that represents all the code domain symbol rates.</p> <p>When I/Q Combined=On, total is 16 for Data, 32 for Pilot, and 64 for MAC. If the active channel occupies more than the max spreading factor (16 for Data, 32 for Pilot, and 64 for MAC) the power is duplicated.</p> <p>1st number = 1st code symbol rate over the slot 2nd number = 2nd code symbol rate over the slot ... Nth number = Nth code symbol rate over the slot</p> <p>When I/Q Combined=Off, results are returned alternatively. Total is 16 I/Q pairs for Data, 32 for Pilot, and 64 for MAC. If the active channel occupies more than the max spreading factor (16 for Data, 32 for Pilot, and 64 for MAC) the power is duplicated.</p> <p>1st number = 1st in-phase code symbol rate over the slot 2nd number = 1st quad-phase code symbol rate over the slot ... (2×N-1)th number = Nth in-phase code symbol rate over the slot (2×N)th number = Nth quad-phase code symbol rate over a slot</p> <p>N = the number of codes detected. The total number of codes varies because of the different symbol rates of each code.</p>

n	Results Returned
3 W-CDMA mode	<p>Returns a series of floating point numbers (in symbol rate) that represent all code domain symbol rates.</p> <p>With a device of BTS, there are 512 numbers. If the active channel occupies more than the max spreading factor (7.5 ksp) the power is duplicated (active symbol rate/7.5 ksp) times.</p> <p>1st number = 1st code symbol rate over the slot 2nd number = 2nd code symbol rate over the slot ... Nth number = Nth code symbol rate over the slot</p> <p>With a device of MS, there are 256 I/Q pairs. If the active channel occupies more than the max spreading factor (15 ksp) the power is duplicated (active symbol rate/15 ksp) times.</p> <p>1st number = 1st in-phase code symbol rate over the slot 2nd number = 1st quad-phase code symbol rate over the slot ... (2×N-1)th number = Nth in-phase code symbol rate over the slot (2×N)th number = Nth quad-phase code symbol rate over the slot</p> <p>N = the number of codes detected. The total number of codes varies because of the different symbol rates of each code.</p>
4 cdmaOne mode	<p>Returns floating point numbers that are the trace data of the code domain <i>phase</i> trace for all 64 Walsh codes. This series of 64 numbers represent the relative phase estimations (in radians) of the codes, relative to the pilot channel. Typical values are on the order of 1 mrad.</p>
4 cdma2000 or W-CDMA mode	<p>Returns a series of floating point numbers that show either active or inactive status for each of the code powers returned in n=2. (See above.) If a code is inactive, the value returned is 0.0, otherwise a value >0.0 is returned.</p> <p>1st number = active or inactive flag of the 1st code ... Nth number = active or inactive flag of the Nth code</p> <p>(where N= the number of codes identified)</p>

n	Results Returned
<p>4 1xEV-DO mode</p>	<p>Returns a series of floating point numbers that show either active or inactive status for each of the code powers returned in n=2 and 3. If a code is inactive, the value returned is 0.0, otherwise a value >0.0 is returned.</p> <p>When I/Q Combined=On, I/Q combined results are returned. 1st number = active or inactive flag of the 1st code ... Nth number = active or inactive flag of the Nth code</p> <p>When channel type=Pilot or MAC, results are returned alternatively. 1st number = 1st in-phase code active flag 2nd number = 1st Quad Phase code active flag ... (2×N-1)th number = Nth in-phase code active flag (2×N)th number = Nth Quad Phase code active flag</p> <p>N = the number of codes detected. The total number of codes varies because of the different symbol rates of each code. 2nd number = 1st quad-phase code symbol rate over the slot</p>
<p>5 cdma2000, or W-CDMA mode</p>	<p>Returns a series of floating point numbers (in percent) that represent each sample in the <i>EVM</i> trace. The first number is the symbol 0 decision point and there are X points per symbol. Therefore, the decision points are at 0, 1×X, 2×X, 3×X. . .</p> <p>(where X = the number of points per chip)</p>
<p>5 1xEV-DO mode</p>	<p>Returns series of floating point numbers that alternately represent I and Q pairs of the <i>corrected measured</i> trace. The magnitude of each I and Q pair is normalized to 1.0. The first number is the in-phase (I) sample of symbol 0 decision point and the second is the quadrature-phase (Q) sample of symbol 0 decision point. As in the EVM, there are X points per symbol, so that:</p> <p>1st number is I of the symbol 0 decision point 2nd number is Q of the symbol 0 decision point ... (2×X)+1 number is I of the symbol 1 decision point (2×X)+2 number is Q of the symbol 1 decision point ... (2×X)×N+1th number is I of the symbol N decision point (2×X)×N+2th number is Q of the symbol N decision point</p> <p>where X = the number of points per symbol, and N = the number of symbols</p>
<p>6 cdma2000, or W-CDMA mode</p>	<p>Returns a series of floating point numbers (in percent) that represent each sample in the <i>magnitude error</i> trace. The first number is the symbol 0 decision point and there are X points per symbol. Therefore, the decision points are at 0, 1×X, 2×X, 3×X. . .</p> <p>(where X = the number of points per chip)</p>

n	Results Returned
6 1xEV-DO mode	Returns series of floating point numbers (in dBm) that represent the trace data of the chip power vs. time.
7 cdma2000, or W-CDMA mode	Returns a series of floating point numbers (in degrees) that represent each sample in the <i>phase error</i> trace. The first number is the symbol 0 decision point and there are X points per symbol. Therefore, the decision points are at 0, 1×X, 2×X, 3×X. . . (where X = the number of points per chip)
8 cdma2000, or W-CDMA mode	Returns series of floating point numbers that alternately represent I and Q pairs of the <i>corrected measured</i> trace. The magnitude of each I and Q pair is normalized to 1.0. The first number is the in-phase (I) sample of symbol 0 decision point and the second is the quadrature-phase (Q) sample of symbol 0 decision point. As in the EVM, there are X points per symbol, so that: 1st number is I of the symbol 0 decision point 2nd number is Q of the symbol 0 decision point ... (2×X)+1 number is I of the symbol 1 decision point (2×X)+2 number is Q of the symbol 1 decision point ... (2×X)×N+1th number is I of the symbol N decision point (2×X)×N+2th number is Q of the symbol N decision point where X = the number of points per symbol, and N = the number of symbols
9 cdma2000, or W-CDMA mode	Returns series of floating point numbers (in dBm) that represent the trace data of the symbol power vs. time.
10 cdma2000, or W-CDMA mode	Returns series of floating point numbers (in dBm) that represent the trace data of the chip power vs. time.
11 cdma2000	Returns a series of floating point numbers (0.0 or 1.0) of the symbol values (demodulated bits) for the selected spread code. The results are returned as alternating values of I,Q,I,Q . . . for the entire measurement interval.
11 W-CDMA mode	Returns series of floating point numbers (0.0 or 1.0) of symbol values for the selected code with the entire capture length, when :CALCulate:CDPower:DBITs[:FORMat] is set to BINary. Returns series of floating point numbers (0.0, 1.0 or -1.0) of symbol values for the selected code with the entire capture length, when :CALCulate:CDPower:DBITs[:FORMat] is set to TRISate. “-1.0” represents DTX (Discontinuous Transmission) bit.

MEASure Group of Commands

n	Results Returned
12 W-CDMA mode	Returns series of floating point numbers (0.0 or 1.0) of symbol values for the selected code with the period selected by Meas Interval, and Meas Offset and tDPCH, when :CALCulate:CDPower:DBITs[:FORMat] is set to BINary. Returns series of floating point numbers (0.0, 1.0 or -1.0) of symbol values for the selected code with the period selected by Meas Interval, and Meas Offset and tDPCH, when :CALCulate:CDPower:DBITs[:FORMat] is set to TRIState. “-1.0” represents DTX (Discontinuous Transmission) bit.

Channel Power Measurement

For E4406A this measures the total rms power in a specified integration bandwidth. You must be in the Basic, cdmaOne, cdma2000, W-CDMA, or 1xEV-DO mode to use these commands. Use INSTRument:SElect to set the mode.

The general functionality of CONFigure, FETCh, MEASure, and READ are described at the beginning of this section. See the SENSE:CHPower commands for more measurement related commands.

- :CONFigure:CHPower
- :INITiate:CHPower
- :FETCh:CHPower[n]?
- :READ:CHPower[n]?
- :MEASure:CHPower[n]?

History: For E4406A:
Added to Basic mode, version A.03.00 or later

Front Panel
Access: **Measure, Channel Power**

After the measurement is selected, press **Restore Meas Defaults** to restore factory defaults.

Measurement Results Available

n	Results Returned
0	Returns unprocessed I/Q trace data, as a series of trace point values, in volts. The I values are listed first in each pair, using the 0 through even-indexed values. The Q values are the odd-indexed values.
n=1 (or not specified)	Returns 2 scalar results: 1. Channel Power is a floating point number representing the total channel power in the specified integration bandwidth. 2. PSD (Power Spectral Density) is the power (in dBm/Hz) in the specified integration bandwidth.
2	Returns floating point numbers that are the captured trace data of the power (in dBm/resolution BW) of the signal. The frequency span of the captured trace data is specified by the Span key.

Spur Close Measurement

This measures the spurious emissions in the transmit band relative to the channel power in the selected channel. You must be in the cdmaOne mode to use these commands. Use INSTRument:SElect to set the mode.

The general functionality of CONFigure, FETCh, MEASure, and READ are described at the beginning of this section. See the SENSE:CSPur commands for more measurement related commands.

:CONFigure:CSPur

:INITiate:CSPur

:FETCh:CSPur[n]?

:READ:CSPur[n]?

:MEASure:CSPur[n]?

Front Panel

Access: **Measure, Spur Close**

After the measurement is selected, press **Restore Meas Defaults** to restore factory defaults.

Measurement Results Available

n	Results Returned
0	Returns unprocessed I/Q trace data, as a series of trace point values, in volts. The I values are listed first in each pair, using the 0 through even-indexed values. The Q values are the odd-indexed values.
n=1 (or not specified)	Returns 3 scalar results: <ol style="list-style-type: none"> 1. The worst spur's frequency difference from channel center frequency (in MHz) 2. The worst spur's amplitude difference from the limit (in dB) 3. The worst spur's amplitude difference from channel power (in dB)
2	Returns trace of the segment containing the worst spur.

EDGE Error Vector Magnitude Measurement

This measures the vector error of the magnitude of each symbol. You must be in the EDGE(w/GSM) mode to use these commands. Use INSTRument:SElect to set the mode.

The general functionality of CONFigure, FETCh, MEASure, and READ are described at the beginning of this section. See the SENSE:EEVM commands for more measurement related commands.

:CONFigure:EEVM

:INITiate:EEVM

:FETCh:EEVM[n]?

:READ:EEVM[n]?

:MEASure:EEVM[n]?

History: Version A.04.00 or later

Front Panel

Access: Measure, EDGE EVM

After the measurement is selected, press **Restore Meas Defaults** to restore factory defaults.

Measurement Results Available

n	Results Returned
0	Returns unprocessed I/Q trace data, as a data array of trace point values, in volts.

n	Results Returned
1 (default)	<p>Returns the following 13 scalar results, in order.</p> <ol style="list-style-type: none"> 1. RMS 95th %tile EVM – a floating point number (in percent) of EVM over 95% of the entire measurement area. 2. RMS EVM – a floating point number (in percent) of EVM over the entire measurement area. 3. Maximum RMS EVM – a floating point number (in percent) of highest EVM over the entire measurement area. 4. Peak EVM – a floating point number (in percent) of the average of the peak EVMs. Take the peak EVMs from each burst and average them together. 5. Maximum peak EVM – a floating point number (in percent) of the maximum peak EVM. Take the peak EVMs from each burst and identify the highest peak. 6. Symbol position of the peak EVM error – an integer number of the symbol position where the peak EVM error is detected. 7. Magnitude error – a floating point number (in percent) of average magnitude error over the entire measurement area. 8. Maximum magnitude error – a floating point number (in percent) of maximum magnitude error over the entire measurement area. 9. Phase error – a floating point number (in degree) of average phase error over the entire measurement area. 10. Maximum Phase error – a floating point number (in degree) of maximum phase error over the entire measurement area. 11. Frequency error – a floating point number (in Hz) of the frequency error in the measured signal. 12. Maximum frequency error – a floating point number (in Hz) of the highest frequency error in the measured signal. 13. I/Q origin offset – a floating point number (in dB) of the I and Q error (magnitude squared) offset from the origin. 14. Droop Error – a floating point number (in dB) of the amplitude droop measured across the 142 symbol burst.
2	<p>Returns series of floating point numbers (in percent) that represent each sample in the EVM vector trace for the last slot. The first number is the symbol 0 decision point and there is 1 point per symbol.</p>
3	<p>Returns series of floating point numbers (in percent) that represent each sample in the magnitude error vector trace for the last slot. The first number is the symbol 0 decision point and there is 1 point per symbol.</p>
4	<p>Returns series of floating point numbers (in degree) that represent each sample in the phase error vector trace for the last slot. The first number is the symbol 0 decision point and there is 1 point per symbol.</p>

n	Results Returned
5	<p>Returns series of floating point numbers that alternately represent I and Q pairs of the final corrected measured data for the last slot. The magnitude of each I and Q pair are normalized to 1.0. The first number is the in-phase (I) sample of symbol 0 decision point and the second is the quadrature-phase (Q) sample of symbol 0 decision point. As in the EVM, there is 1 point per symbol, so the series of numbers is:</p> <p>1st number = I of the symbol 0 decision point 2nd number = Q of the symbol 0 decision point . . . (2) + 1 (or 3rd) number = I of the symbol 1 decision point (2) + 2 (or 4th) number = Q of the symbol 1 decision point . . . (2) × N + 1 number = I of the symbol N decision point (2) × N + 2 number = Q of the symbol N decision point</p>

EDGE Output RF Spectrum Measurement

This measures adjacent channel power. From 1 to 15 offsets can be measured at one time. You must be in the EDGE(w/GSM) mode to use these commands. Use INSTRument:SElect to set the mode.

The general functionality of CONFigure, FETCh, MEASure, and READ are described at the beginning of this section. See the SENSE:EORFspectr commands for more measurement related commands.

```
:CONFigure:EORFspectr
:INITiate:EORFspectr
:FETCh:EORFspectr[n]?
:READ:EORFspectr[n]?
:MEASure:EORFspectr[n]?
```

History: Version A.04.00 or later. Modified in version A.05.00.

Front Panel

Access: **Measure, EDGE Output RF Spectrum**

After the measurement is selected, press **Restore Meas Defaults** to restore factory defaults.

Measurement Results Available

The default settings for the MEASure command only measure the carrier and 5 standard offsets. The default does not measure the switching transients. If you use the CONFigure, INITiate, and FETCh commands in place of the MEASure command, you can then use the SENSE commands to change the settings from these defaults. Use [:SENSE]:EORFspectr:LIST:SWITCh CUSTOM to select a customized set of offsets. Use [:SENSE]:EORFspectr:TYPE MSwitching to measure switching in addition to measuring modulation. (The measurement will take longer when measuring switching transients.)

Measurement Method	n	Results Returned
	0	Returns unprocessed I/Q trace data, as a series of trace point values, in volts. The I values are listed first in each pair, using the 0 through even-indexed values. The Q values are the odd-indexed values.

Measurement Method	n	Results Returned
Single Offset	n=1 (or not specified)	<p>Returns 4 measurement results for the specified offset:</p> <ol style="list-style-type: none"> 1. Modulation spectrum power, dB 2. Modulation spectrum power, dBm 3. Switching transient power, dB 4. Switching transient power, dBm
<p>Multiple Offsets Switching -or- Multiple Offsets Modulation Discrete Mode</p>	n=1 (or not specified)	<p>Returns a list of values for the modulation spectrum at all the offsets (lower and upper.) This is followed by the switching transients results at all the offsets (lower and upper). Note that the carrier is considered offset zero (0) and is the first set of results sent. Four values are provided for each of the offsets (including the carrier), in this order:</p> <ol style="list-style-type: none"> 1. Negative offset(a) - power relative to carrier (dB) 2. Negative offset(a) - absolute average power (dBm) 3. Positive offset(a) - power relative to carrier (dB) 4. Positive offset(a) - absolute average power (dBm) <p>Values for all possible offsets are sent. Zeros are sent for offsets that have not been defined. The total number of values sent $(120) = (4 \text{ results/offset}) \times (15 \text{ offsets}) \times (2 \text{ measurement types - modulation \& switching})$</p> <p>Carrier - modulation measurement values Offset 1 - modulation measurement values ... Offset 14 - modulation measurement values Carrier - switching transients measurement values Offset 1 - switching transients measurement values ... Offset 14- switching transients measurement values</p> <p>This measurement defaults to modulation measurements and not switching measurements. If you want to return the switching measurement values, you must change that default condition and use FETCh or READ to return values, rather than MEASure.</p> <p>NOTE: When using custom modulation and switching offsets the maximum number of measured values returned is:</p> <p>13 modulation offsets + 0 Hz carrier 4 switching offsets + 0 Hz carrier</p>
Multiple Offsets Modulation Sweep Mode	n=1 (or not specified)	<p>Returns 5 measurement results of the closest point to the limit line:</p> <ol style="list-style-type: none"> 1. Frequency 2. Offset frequency from carrier frequency 3. Power in dBm 4. delta from limit (dB) 5. delta from reference (dB)

MEASure Group of Commands

Measurement Method	n	Results Returned
Single Offset	2	Returns floating point numbers (in dBm) of the captured trace data. It contains N data points of the “spectrum due to modulation” signal, where N is the specified number of samples.
Single Offset	3	Returns floating point numbers (in dBm) of the captured trace data. It contains N data points of the “spectrum due to switching transients” signal, where N is the specified number of samples.
Multiple Offsets Modulation	4	Returns floating point numbers (in dBm) of the sweep spectrum of modulation.
Sweep Mode	5	Returns floating point numbers (in dBm) of the limit trace.

EDGE Power vs. Time Measurement

This measures the average power during the “useful part” of the burst comparing the power ramp to required timing mask. You must be in EDGE(w/GSM) mode to use these commands. Use INSTRument:SElect to set the mode.

The general functionality of CONFigure, FETCh, MEASure, and READ are described at the beginning of this section. See the SENSE:EPVTime commands for more measurement related commands.

```
:CONFigure:EPVTime
:INITiate:EPVTime
:FETCh:EPVTime[n]?
:READ:EPVTime[n]?
:MEASure:EPVTime[n]?
```

Front Panel

Access: **Measure, EDGE Pwr vsTime**
After the measurement is selected, press **Restore Meas Defaults** to restore factory defaults.

History: Modified in version A.05.00.

Measurement Results Available

n	Results Returned
0	Returns unprocessed I/Q trace data, as a series of trace point values, in volts. The I values are listed first in each pair, using the 0 through even-indexed values. The Q values are the odd-indexed values.

n	Results Returned
n=1 (or not specified)	<p>Returns the following scalar results:</p> <ol style="list-style-type: none"> 1. Sample time is a floating point number that represents the time between samples when using the trace queries (n=0,2,etc.). 2. Power single burst is the mean power (in dBm) across the useful part of the selected burst in the most recently acquired data, or in the last data acquired at the end of a set of averages. If averaging is on, the power is for the last burst. 3. Power averaged is the power (in dBm) of N averaged bursts, if averaging is on. The power is averaged across the useful part of the burst. Average <i>m</i> is a single burst from the acquired trace. If there are multiple bursts in the acquired trace, only one burst is used for average <i>m</i>. This means that N traces are acquired to make the complete average. If averaging is off, the value of power averaged is the same as the power single burst value. 4. Number of samples is the number of data points in the captured signal. This number is useful when performing a query on the signal (i.e. when n=0,2,etc.). 5. Start is the index of the data point at the start of the useful part of the burst 6. Stop is the index of the data point at the end of the useful part of the burst 7. T_0 is the index of the data point where t_0 occurred 8. Burst width is the width of the burst measured at -3dB below the mean power in the useful part of the burst. 9. Maximum value is the maximum value of the most recently acquired data (in dBm). 10. Minimum value is the minimum value of the most recently acquired data (in dBm). 11. Burst search threshold is the value (in dBm) of the threshold where a valid burst is identified, after the data has been acquired. 12. IQ point delta is the number of data points offset that are internally applied to the useful data in traces $n=2,3,4$. You must apply this correction value to find the actual location of the Start, Stop, or T_0 values. (e.g. for $n=2$, Start (for the IQ trace data) = Start + IQ_point_delta)
2	Returns trace point values of the entire waveform data. These data points are floating point numbers representing the power of the signal (in dBm). There are N data points, where N is the number of samples . The period between the samples is defined by the sample time .
3	Returns data points representing the upper mask (in dBm).
4	Returns data points representing the lower mask (in dBm).

n	Results Returned
7	Returns power level values for the 8 slots in the current frame (in dBm).
8, only available when averaging is set to both maximum and minimum	<p>Returns trace point values of the minimum waveform data. These data points are floating point numbers representing the power of the signal (in dBm). There are N data points, where N is the number of samples. The period between the samples is defined by the sample time.</p> <p>Use SENSE:PVT:AVERAge:TYPE MXMinimum to set averaging to max and min. Use n=2 to return the corresponding maximum trace.</p>

n	Results Returned
<p>n=10</p> <p>GSM (w/EDGE) MODE (PSA only)</p>	<p>Returns the following scalar results (all in floating point numbers):</p> <ol style="list-style-type: none"> 1. Sample time is a floating point number that represents the time between samples when using the trace queries (n=0,2,etc.). 2. Power single burst is the mean power (in dBm) across the useful part of the selected burst in the most recently acquired data, or in the last data acquired at the end of a set of averages. If averaging is on, the power is for the last burst. 3. Power averaged is the power (in dBm) of N averaged bursts, if averaging is on. The power is averaged across the useful part of the burst. Average <i>m</i> is a single burst from the acquired trace. If there are multiple bursts in the acquired trace, only one burst is used for average <i>m</i>. This means that N traces are acquired to make the complete average. If averaging is off, the value of power averaged is the same as the power single burst value. 4. Number of samples is the number of data points in the captured signal. This number is useful when performing a query on the signal (i.e. when n=0,2,etc.). 5. Start is the index of the data point at the start of the useful part of the burst 6. Stop is the index of the data point at the end of the useful part of the burst 7. T_0 is the index of the data point where t_0 occurred 8. Burst width is the width of the burst measured at -3dB below the mean power in the useful part of the burst. 9. Maximum value is the maximum value of the most recently acquired data (in dBm). 10. Minimum value is the minimum value of the most recently acquired data (in dBm). 11. Burst search threshold is the value (in dBm) of the threshold where a valid burst is identified, after the data has been acquired. 12. IQ point delta is the number of data points offset that are internally applied to the useful data in traces $n=2,3,4$. You must apply this correction value to find the actual location of the Start, Stop, or T_0 values. (e.g. for $n=2$, Start (for the IQ trace data) = Start + IQ_point_delta) 13. Trigger to T0 time is the elapsed time interval between the trigger point and T_0. The time of the trigger point is known and the T_0 time is calculated by the demodulation algorithm. The difference is the elapsed Trigger to T_0 time.

EDGE Transmit Band Spurs Measure Commands

This measures the spurious emissions in the transmit band relative to the channel power in the selected channel. You must be in the EDGE mode to use these commands. Use INSTRument:SELEct to set the mode.

The general functionality of CONFigure, FETCh, MEASure, and READ are described at the beginning of this section. See the SENSE:TSPur commands for more measurement related commands.

:CONFigure:ETSPur

:INITiate:ETSPur

:FETCh:ETSPur[n]?

:READ:ETSPur[n]?

:MEASure:ETSPur[n]?

History: Version A.05.00 or later

Front Panel

Access: Measure, EDGE Tx Band Spurs

After the measurement is selected, press **Restore Meas Defaults** to restore factory defaults.

Measurement Results Available

n	Results Returned
0	Returns unprocessed I/Q trace data, as a series of trace points, in volts. The I values are listed first in each pair, using the 0 through even-indexed values. The Q values are the odd-indexed values.
n=1 (or not specified)	Returns 3 scalar results: <ol style="list-style-type: none"> 1. The worst spur's frequency difference from channel center frequency (in MHz) 2. The worst spur's amplitude difference from the limit (in dB) 3. The worst spur's amplitude difference from the mean transmit power (in dB)
2	Returns trace of the current segment spectrum.
3	[Returns trace of the current segment Upper Limit.]
4	Returns trace of Lower segment Spectrum.
5	Returns trace of Lower segment Upper Limit.
6	Returns trace of Lower Adj segment Spectrum.
7	Returns trace of Lower Adj segment Upper Limit.

MEASure Group of Commands

n	Results Returned
8	Returns trace of Upper Adj segment Spectrum.
9	Returns trace of Upper Adj segment Upper Limit.
10	Returns trace of Upper segment Spectrum.
11	Returns trace of Upper segment Upper Limit.

Error Vector Magnitude Measurement

This measures the vector error of the magnitude of each symbol. You must be in the NADC or PDC mode to use these commands. Use INSTRument:SElect to set the mode.

The general functionality of CONFigure, FETCh, MEASure, and READ are described at the beginning of this section. See the SENSE:EVM commands for more measurement related commands.

:CONFigure:EVM

:INITiate:EVM

:FETCh:EVM[n]?

:READ:EVM[n]?

:MEASure:EVM[n]?

History: Version A.02.00 or later

Front Panel

Access: Measure, EVM

After the measurement is selected, press **Restore Meas Defaults** to restore factory defaults.

Measurement Results Available

n	Results Returned
0	Returns unprocessed I/Q trace data, as a data array of trace point values, in volts.

n	Results Returned
<p>1 (default) EDGE GSM mode</p>	<p>Returns the following 8 scalar results, in order.</p> <ol style="list-style-type: none"> 1. RMS EVM – a floating point number (in percent) of EVM over the entire measurement area. 2. Peak EVM error – a floating point number (in percent) of the peak EVM in the measurement area. 3. Symbol position of the peak EVM error – an integer number of the symbol position where the peak EVM error is detected. 4. First 10 symbols EVM error – a floating point number (in percent) of EVM over the first 10 symbols. 5. Magnitude error – a floating point number (in percent) of average magnitude error over the entire measurement area. 6. Phase error – a floating point number (in degree) of average phase error over the entire measurement area. 7. Frequency error – a floating point number (in Hz) of the frequency error in the measured signal. 8. I/Q origin offset – a floating point number (in dB) of the I and Q error (magnitude squared) offset from the origin.
<p>1 (default) NADC mode</p>	<p>Returns the following 8 scalar results, in order.</p> <ol style="list-style-type: none"> 1. RMS EVM – a floating point number (in percent) of EVM over the entire measurement area. 2. Peak EVM error – a floating point number (in percent) of the peak EVM in the measurement area. 3. Symbol position of the peak EVM error – an integer number of the symbol position where the peak EVM error is detected. 4. First 10 symbols EVM error – a floating point number (in percent) of EVM over the first 10 symbols. 5. Magnitude error – a floating point number (in percent) of average magnitude error over the entire measurement area. 6. Phase error – a floating point number (in degree) of average phase error over the entire measurement area. 7. Frequency error – a floating point number (in Hz) of the frequency error in the measured signal. 8. I/Q origin offset – a floating point number (in dB) of the I and Q error (magnitude squared) offset from the origin.

n	Results Returned
<p>1 (default) PDC mode</p>	<p>Returns the following 7 scalar results, in order.</p> <ol style="list-style-type: none"> 1. RMS EVM – a floating point number (in percent) of EVM over the entire measurement area. 2. Peak EVM error – a floating point number (in percent) of peak EVM in the measurement area. 3. Symbol position of the peak EVM error – an integer number of the symbol position where the peak EVM error is detected. 4. Magnitude error – a floating point number (in percent) of average magnitude error over the entire measurement area. 5. Phase error – a floating point number (in degree) of average phase error over the entire measurement area. 6. Frequency error – a floating point number (in Hz) of the frequency error in the measured signal. 7. I/Q origin offset – a floating point number (in dB) of the I and Q error (magnitude squared) offset from the origin.
<p>2</p>	<p>Returns series of floating point numbers (in percent) that represent each sample in the EVM trace. The first number is the symbol 0 decision point and there are 5 points per symbol. Therefore, the decision points are at 0, 5, 10, 15. . . .</p>
<p>3</p>	<p>Returns series of floating point numbers (in percent) that represent each sample in the magnitude error trace. The first number is the symbol 0 decision point and there are 5 points per symbol. Therefore, the decision points are at 0, 5, 10, 15. . . .</p>
<p>4</p>	<p>Returns series of floating point numbers (in degree) that represent each sample in the phase error trace. The first number is the symbol 0 decision point and there are 5 points per symbol. Therefore, the decision points are at 0, 5, 10, 15</p>
<p>5</p>	<p>Returns series of floating point numbers that alternately represent I and Q pairs of the corrected measured trace. The magnitude of each I and Q pair are normalized to 1.0. The first number is the in-phase (I) sample of symbol 0 decision point and the second is the quadrature-phase (Q) sample of symbol 0 decision point. As in the EVM, there are 5 points per symbol, so the series of numbers is:</p> <p style="margin-left: 40px;"> 1st number = I of the symbol 0 decision point 2nd number = Q of the symbol 0 decision point . . . (2 × 5) + 1 (or 11th) number = I of the symbol 1 decision point (2 × 5) + 2 (or 12th) number = Q of the symbol 1 decision point . . . (2 × 5) × N + 1 number = I of the symbol N decision point (2 × 5) × N + 2 number = Q of the symbol N decision point </p>

MEASure Group of Commands

n	Results Returned
6 NADC mode	Returns the following 4 scalar values of 1 or 0, in the order given. The pass/fail results (0=passed, or 1=failed) are determined by testing the EVM, peak EVM, first 10 symbols EVM and IQ origin offsets. Test result of EVM Test result of peak EVM Test result of first 10 symbols EVM Test result of IQ origin offset
6 PDC mode	Returns the following 3 scalar values of 1 or 0, in the order given. The pass/fail results (0=passed, or 1=failed) are determined by testing the EVM, peak EVM, and IQ origin offsets. Test result of EVM Test result of peak EVM Test result of IQ origin offset
0 Modulation Analysis Mode	Returns processed raw, unprocessed I/Q trace data, as a data array of trace point values, in volts. The I values are listed first in each pair, using the 0 through even-indexed values. The Q values are the odd-indexed values.

n	Results Returned
not specified or n=1 Modulation Analysis Mode	<p>Returns 26 comma separated floating point numbers in the following order:</p> <ol style="list-style-type: none"> 1. EVM (rms) Avg has units of percent. The calculation is based on the composite of the phase error and magnitude error, between the measured signal and the ideal signal. If averaging is on, this is the average of the individual rms measurements. 2. EVM (rms) Max has units of percent. The calculation is based on the composite of the phase error and magnitude error, between the measured signal and the ideal signal. This is the maximum of the individual rms measurements. 3. EVM (peak) Avg has units of percent. The calculation is based on the composite of the phase error and magnitude error, between the measured signal and the ideal signal. If averaging is on, this is the average of the individual peak measurements. 4. Symbol position of the EVM (peak) Avg error – an integer number of the symbol position where the last averaged peak EVM error is detected. 5. EVM (peak) Max has units of percent. The calculation is based on the composite of the phase error and magnitude error, between the measured signal and the ideal signal. If averaging is on, this is the maximum of the individual peak measurements. 6. Symbol position of the EVM (peak) Max error – an integer number of the symbol position where the maximum peak EVM error is detected. 7. Magnitude Error rms Avg (with units of percent) is the rms error between the measured (compensated) magnitude and the ideal magnitude. If averaging is on, this is the average of the individual rms measurements. 8. Magnitude Error rms Max (with units of percent) is the rms error between the measured (compensated) magnitude and the ideal magnitude. This is the maximum of the individual rms measurements. 9. Magnitude Error (peak) Average (with units of percent) is the peak error between the measured (compensated) magnitude and the ideal magnitude. If averaging is on, this is the average of the individual peak measurements. 10. Symbol position of the Magnitude Error (peak) Avg – an integer number representing the symbol position where the last averaged peak magnitude error was detected. 11. Magnitude Error (peak) Max (with units of percent) is the peak error between the measured (compensated) magnitude and the ideal magnitude. This is the maximum of the individual peak measurements.

n	Results Returned
<p>Not specified or n = 1</p>	<p>12. Symbol position of the Magnitude Error (peak) Max – an integer number representing the symbol position where the maximum peak magnitude error was detected.</p> <p>13. Phase Error (rms) Average (with units in degrees) is the rms error between the measured (compensated) phase and the ideal phase. If averaging is on, this is the average of the individual rms measurements.</p> <p>14. Phase Error (rms) Max (with units in degrees) is the rms error between the measured (compensated) phase and the ideal phase. This is the maximum of the individual rms measurements.</p> <p>15. Phase Error Average Peak (with units in degrees) is the peak error between the measured (compensated) phase and the ideal phase. If averaging is on, this is the average of the individual peak measurements.</p> <p>16. Symbol position of the Phase Error (peak) Avg – an integer number representing the symbol position where the last averaged peak Phase error was detected.</p> <p>17. Phase Error (peak) Max (with units in degrees) is the peak phase error between the measured phase and the ideal phase. This is the maximum of the individual peak measurements.</p> <p>18. Symbol position of the Phase Error (peak) Max – an integer number representing the symbol position where the maximum peak Phase error was detected.</p> <p>19. Frequency Error Avg of the measured signal, has units of Hz. This is based on the linear best fit of the uncorrected measured phase. If averaging is on, this is the average of the individual frequency error measurements.</p> <p>20. Frequency Error Max of the measured signal, has units of Hz. This is based on the linear best fit of the uncorrected measured phase. This is the maximum of the individual frequency error measurements.</p> <p>21. I/Q Offset Avg (with units of dB) is the dc error offset of I/Q, from the origin. If averaging is on, this is the average of the individual carrier feed-through measurements.</p> <p>22. I/Q Offset Max (with units of dB) is the dc error offset of I/Q, from the origin. This is the maximum of the individual carrier feed-through measurements.</p> <p>23. Amplitude Droop Error Avg has units dB/symbol. This is the linear best fit of the amplitude slope of the measured signal. If averaging is on, this is the average of the individual measurements.</p> <p>24. Amplitude Droop Error Max has units dB/symbol. This is the linear best fit of the amplitude slope of the measured signal. This is the maximum of the individual measurements.</p> <p>25. Trace Time Sample is a floating point number (in seconds) of the time between samples for the Corrected I/Q trace. This is the time between I/Q pairs.</p>

n	Results Returned
Not specified or N=1	26. Corrected I/Q Vector Trace Length is an integer (in number of samples) representing the number of samples returned by the Corrected I/Q Trace. In other words, this number divided by 2 represents the number of sample pairs in the trace.
2	EVM Trace - Returns a trace of the error vector magnitude (EVM), as trace point values in percent. The first value is the symbol 0 decision point. The trace is interpolated for the currently selected points/symbol displayed on the front panel. The number of trace points depends on the current measurement interval setting. For GSM, one NAN will be returned as this is an unsupported trace.
3	Mag Error Trace - Returns a trace of the magnitude error, as trace point values in percent. The first value is the symbol 0 decision point. The trace is interpolated for the currently selected points/symbol displayed on the front panel. The number of trace points depends on the current measurement interval setting. For GSM, one NAN will be returned as this is an unsupported trace.
4	Phase Error Trace - Returns a trace of the phase error, as trace point values in percent. The first value is the symbol 0 decision point. The trace is interpolated for the currently selected points/symbol displayed on the front panel. The number of trace points depends on the current measurement interval setting.
5	Measured Polar Vector IQ trace - Returns a trace of the IQ measured polar vector IQ complex data array, as trace point values in dB. The first value is the symbol 0 (I component) decision point. The second value is the symbol 0 (Q component) decision point, and so on. The trace is interpolated for the currently selected points/symbol displayed on the front panel. The number of trace points depends on the current measurement interval setting.

QPSK Error Vector Magnitude Measurement

This measures the QPSK error vector magnitude of each symbol. You must be in the cdma2000, W-CDMA, or 1xEV-DO mode to use these commands. Use INSTRument:SElect to set the mode.

The general functionality of CONFigure, FETCh, MEASure, and READ are described at the beginning of this section. See the SENSE:EVMQpsk commands for more measurement related commands.

```
:CONFigure:EVMQpsk
:INITiate:EVMQpsk
:FETCh:EVMQpsk[n]?
:READ:EVMQpsk[n]?
:MEASure:EVMQpsk[n]?
```

History: Version A.03.00 or later

Front Panel

Access: **Measure, QPSK EVM**

After the measurement is selected, press **Restore Meas Defaults** to restore factory defaults.

Measurement Results Available

n	Results Returned
0	Returns unprocessed I/Q trace data, as a data array of trace point values, in volts.

n	Results Returned
1 (default)	<p>Returns 11 scalar results, in the following order.</p> <ol style="list-style-type: none"> 1. RMS EVM is a floating point number (in percent) of EVM over the entire measurement area. 2. RMS EVM maximum is the maximum RMS EVM over the averaged counts 3. Peak EVM is a floating point number (in percent) of peak EVM in the measurement area. 4. Peak EVM maximum is the maximum peak EVM over the averaged counts. 5. Magnitude error is a floating point number (in percent) of average magnitude error over the entire measurement area. 6. Magnitude error maximum is the maximum magnitude error over the averaged counts. 7. Phase error is a floating point number (in degree) of average phase error over the entire measurement area. 8. Phase error maximum is the maximum phase error over the averaged counts. 9. Frequency error is a floating point number (in Hz) of the frequency error in the measured signal. 10. Frequency error maximum is the maximum frequency error over the averaged counts. 11. I/Q origin offset is a floating point number (in dB) of the I and Q error (magnitude squared) offset from the origin.
2	<p>EVM trace – returns series of floating point numbers (in percent) that represent each sample in the EVM trace. The first number is the symbol 0 decision point. There are X points per symbol ($X = \text{points/chip}$). Therefore, the decision points are at $0, 1 \times X, 2 \times X, 3 \times X \dots$</p>
3	<p>Magnitude error trace – returns series of floating point numbers (in percent) that represent each sample in the magnitude error trace. The first number is the symbol 0 decision point. There are X points per symbol ($X = \text{points/chip}$). Therefore, the decision points are at $0, 1 \times X, 2 \times X, 3 \times X \dots$</p>
4	<p>Phase error trace – returns series of floating point numbers (in degree) that represent each sample in the phase error trace. There are X points per symbol ($X = \text{points/ chip}$). Therefore, the decision points are at $0, 1 \times X, 2 \times X, 3 \times X \dots$</p>

n	Results Returned
5	<p>Corrected measured trace – returns series of floating point numbers that alternately represent I and Q pairs of the corrected measured trace. The magnitude of each I and Q pair are normalized to 1.0. The first number is the in-phase (I) sample of symbol 0 decision point and the second is the quadrature-phase (Q) sample of symbol 0 decision point. There are X points per symbol ($X = \text{points/chip}$), so the series of numbers is:</p> <p>1st number = I of the symbol 0 decision point 2nd number = Q of the symbol 0 decision point</p> <p style="text-align: center;">. . .</p> <p>$(2 \times X) + 1$, number = I of the symbol 1 decision point $(2 \times X) + 2$, number = Q of the symbol 1 decision point</p> <p style="text-align: center;">. . .</p> <p>$(2 \times X) \times N\text{th} + 1$ number = I of the symbol N decision point $(2 \times X) \times N\text{th} + 2$ number = Q of the symbol N decision point</p>

Intermodulation Measurement

This measures the third order and fifth order intermodulation products caused by the wanted signal and the interfering signal. You must be in cdma2000, W-CDMA, or 1xEV-DO mode to use these commands. Use INSTRument:SElect to set the mode.

The general functionality of CONFigure, FETCh, MEASure, and READ are described at the beginning of this section. See the SENSE:IM commands for more measurement related commands.

```
:CONFigure:IM
:INITiate:IM
:FETCh:IM[n]?
:READ:IM[n]?
:MEASure:IM[n]?
```

Front Panel

Access: **Measure, Intermod**

After the measurement is selected, press **Restore Meas Defaults** to restore factory defaults.

Measurement Results Available

n	Results Returned
0	Returns unprocessed I/Q trace data that acquired in the last acquisition when multiple acquisition is performed, as a data array of trace point values, in volts.

n	Results Returned
1 (default)	<p>Returns 23 scalar results in the following order.</p> <ol style="list-style-type: none"> 1. Absolute power of the reference (dBm) 2. Base lower frequency (Hz) 3. Base lower absolute power (dBm) 4. Base lower relative power to the reference (dBc) 5. Base upper frequency (Hz) 6. Base upper absolute power (dBm) 7. Base upper relative power to the reference (dBc) 8. Third order lower frequency (Hz) 9. Third order lower absolute power (dBm) 10. Third order lower relative power to the reference power (dBc) 11. Third order lower power spectrum density (dBm/Hz) 12. Third order upper frequency (Hz) 13. Third order upper absolute power (dBm) 14. Third order upper relative power to the reference power (dBc) 15. Third order upper power spectrum density (dBm/Hz) 16. Fifth order lower frequency (Hz) 17. Fifth order lower absolute power (dBm) 18. Fifth order lower relative power to the reference power (dBc) 19. Fifth order lower power spectrum density (dBm/Hz) 20. Fifth order upper frequency (Hz) 21. Fifth order upper absolute power (dBm) 22. Fifth order upper relative power to the reference power (dBc) 23. Fifth order upper power spectrum density (dBm/Hz) <p>If the results are not available, -999.0 is returned for the power results and 0.0 for the frequency results.</p>
2 cdma2000, 1xEV-DO mode	<p>Returns a series of floating point numbers that represent the frequency-domain spectrum trace for the entire frequency range being measured.</p> <p>In the default settings (SENSe:IM:FREQuency:SPAN 20 MHz; SENSe:IM:BANDwidth BWIDth[:RESolution] 140 kHz), there are 345 numbers.</p>
2 W-CDMA mode	<p>Returns a series of floating point numbers that represent the frequency-domain spectrum trace for the entire frequency range being measured.</p> <p>In the default settings (SENSe:IM:FREQuency:SPAN 50 MHz; SENSe:IM:BANDwidth BWIDth[:RESolution] 140 kHz), there are 872 numbers.</p>

n	Results Returned
3	<p>Returns 2 scalar values of the measured mode determined by the Auto algorithm.</p> <ul style="list-style-type: none">1. Measurement Mode:<ul style="list-style-type: none">1: Two-tone2: Transmit IM3: Auto (Two-tone)4: Auto (Transmit IM)5: Unknown2. Reference:<ul style="list-style-type: none">1: Lower2: Upper3: Average4: Auto (Lower)5: Auto (Upper)

Multi Carrier Power Measurement

This measures the power levels of two input carriers, out-of-channels from them, and the channels between them. You must be in W-CDMA mode to use these commands. Use INSTRument:SElect to set the mode.

The general functionality of CONFigure, FETCh, MEASure, and READ are described at the beginning of this section. See the SENSE:MCPower commands for more measurement related commands.

:CONFigure:MCPower

:INITiate:MCPower

:FETCh:MCPower[n]?

:READ:MCPower[n]?

:MEASure:MCPower[n]?

Front Panel

Access: **Measure, Multi Carrier Power**

After the measurement is selected, press **Restore Meas Defaults** to restore factory defaults.

Measurement Results Available

n	Results Returned
0	Returns unprocessed I/Q trace data, as a data array of trace point values, in volts.

n	Results Returned
1 (default)	<p>Returns 25 scalar results, in the following order.</p> <ol style="list-style-type: none"> 1. Reference – absolute power (dBm) 2. Center frequency – relative power (dBc) 3. Center frequency – absolute power (dBm) 4. Second carrier frequency – relative power (dBc) 5. Second carrier frequency – absolute power (dBm) 6. –5 MHz offset frequency adjacent to the center frequency – relative power (dBc) 7. –5 MHz offset frequency adjacent to the center frequency – absolute power (dBc) 8. –5 MHz offset frequency adjacent to the second carrier frequency – relative power (dBc) 9. –5 MHz offset frequency adjacent to the second carrier frequency – absolute power (dBc) 10. Reserved for future use, returns –999.0. 11. Reserved for future use, returns –999.0. 12. Reserved for future use, returns –999.0. 13. Reserved for future use, returns –999.0. 14. Negative offset frequency (1) – relative power (dBc) 15. Negative offset frequency (1) – absolute power (dBm) 16. Positive offset frequency (1) – relative power (dBc) 17. Positive offset frequency (1) – absolute power (dBm) 18. Negative offset frequency (2) – relative power (dBc) 19. Negative offset frequency (2) – absolute power (dBm) 20. Positive offset frequency (2) – relative power (dBc) 21. Positive offset frequency (2) – absolute power (dBm) 22. Negative offset frequency (3) – relative power (dBc) 23. Negative offset frequency (3) – absolute power (dBm) 24. Positive offset frequency (3) – relative power (dBc) 25. Positive offset frequency (3) – absolute power (dBm) <p>If the results are not available, –999.0 is returned for the power results and 0.0 for the frequency results.</p>
2	<p>Returns 10 scalar values of the pass/fail (0 for pass, and 1 for fail) results determined by testing the power based on the limit setting.</p> <ol style="list-style-type: none"> 1. –5 MHz offset frequency adjacent to the center frequency 2. –5 MHz offset frequency adjacent to the second carrier frequency 3. Reserved for future use, returns 0.0. 4. Reserved for future use, returns 0.0. 5. Negative offset frequency (1) 6. Positive offset frequency (1) 7. Negative offset frequency (2) 8. Positive offset frequency (2) 9. Negative offset frequency (3) 10. Positive offset frequency (3) <p>If the results are not available, 0.0 is returned.</p>

Occupied Bandwidth Measurement

This measures the bandwidth of the carrier signal in the occupied part of the channel. You must be in the PDC, iDEN (E4406A only), cdma2000, W-CDMA, or 1xEV-DO mode to use these commands. Use INSTRument:SElect to set the mode.

The general functionality of CONFigure, FETCh, MEASure, and READ are described at the beginning of this section. See the SENSE:OBW commands for more measurement related commands.

:CONFigure:OBW

:INITiate:OBW

:FETCh:OBW[n]?

:READ:OBW[n]?

:MEASure:OBW[n]?

History: E4406A:
Version A.02.00 or later

Front Panel

Access: **Measure, Occupied BW**

After the measurement is selected, press **Restore Meas Defaults** to restore factory defaults.

Measurement results available

n	Results Returned
0	Returns unprocessed I/Q trace data, as a data array of trace point values, in volts.
1 (default) PDC, cdma2000, W-CDMA mode	Returns 2 scalar results, in the following order: 1. Occupied bandwidth - Hz 2. Absolute Carrier Power - dBm
1 (default) 1xEV-DO mode	Returns 2 scalar results, in the following order: 1. Occupied bandwidth - Hz 2. Absolute Carrier Power - dBm 3. Span - Hz 4. Spectrum Trace Points - points 5. Res BW - Hz

n	Results Returned
1 (default) iDEN mode E4406A	Returns the following 7 scalar results, in order. <ol style="list-style-type: none"> 1. Absolute power of occupied bandwidth (dBm) 2. Relative power of occupied bandwidth (dB) 3. Bandwidth for specified power percentage 4. Power percentage 5. Measured carrier frequency 6. Frequency span 7. Average count
2 PDC, cdma2000, W-CDMA, 1xEV-DO mode	Returns the frequency-domain spectrum trace (data array) for the entire frequency range being measured.
2, spectrum display only iDEN mode E4406A	Returns the frequency-domain spectrum trace (data array) for the entire frequency range (9003 points) being measured.

Output RF Spectrum Measurement

This measures adjacent channel power. From 1 to 15 offsets can be measured at one time. You must be in the EDGE, GSM mode to use these commands. Use INSTRument:SElect to set the mode.

The general functionality of CONFigure, FETCh, MEASure, and READ are described at the beginning of this section. See the SENSE:ORFSpectrum commands for more measurement related commands.

```
:CONFigure:ORFSpectrum
:INITiate:ORFSpectrum
:FETCh:ORFSpectrum[n]?
:READ:ORFSpectrum[n]?
:MEASure:ORFSpectrum[n]?
```

Front Panel

Access: **Measure, Output RF Spectrum**

After the measurement is selected, press **Restore Meas Defaults** to restore factory defaults.

Measurement Results Available

The default settings for the MEASure command only measure the carrier and 5 standard offsets. The default does not measure the switching transients. If you use the CONFigure, INITiate, and FETCh commands in place of the MEASure command, you can then use the SENSE commands to change the settings from these defaults. Use [:SENSE]:ORFSpectrum:LIST:SWITCh CUSTOM to select a customized set of offsets. Use [:SENSE]:ORFSpectrum:TYPE MSwitching to measure switching in addition to measuring modulation. (The measurement will take longer when measuring switching transients.)

Measurement Method	n	Results Returned
	0	Returns unprocessed I/Q trace data, as a series of trace point values, in volts. The I values are listed first in each pair, using the 0 through even-indexed values. The Q values are the odd-indexed values.
Single Offset	n=1 (or not specified)	Returns 4 measurement results for the specified offset: <ol style="list-style-type: none"> 1. Modulation spectrum power, dB 2. Modulation spectrum power, dBm 3. Switching transient power, dB 4. Switching transient power, dBm

Measurement Method	n	Results Returned
<p>Multiple Offsets Switching -or- Multiple Offsets Modulation Discrete Mode</p>	<p>n=1 (or not specified)</p>	<p>Returns a list of values for the modulation spectrum at all the offsets (lower and upper.) This is followed by the switching transients results at all the offsets (lower and upper). Note that the carrier is considered offset zero (0) and is the first set of results sent. Four values are provided for each of the offsets (including the carrier), in this order:</p> <ol style="list-style-type: none"> 1. Negative offset(a) - power relative to carrier (dB) 2. Negative offset(a) - absolute average power (dBm) 3. Positive offset(a) - power relative to carrier (dB) 4. Positive offset(a) - absolute average power (dBm) <p>Values for all possible offsets are sent. Zeros are sent for offsets that have not been defined. The total number of values sent (120) = (4 results/offset) × (15 offsets) × (2 measurement types - modulation & switching)</p> <p>Carrier - modulation measurement values Offset 1 - modulation measurement values ... Offset 14 - modulation measurement values Carrier - switching transients measurement values Offset 1 - switching transients measurement values ... Offset 14- switching transients measurement values</p> <p>This measurement defaults to modulation measurements and not switching measurements. If you want to return the switching measurement values, you must change that default condition and use FETCh or READ to return values, rather than MEASure.</p> <p>NOTE: When using custom modulation and switching offsets the maximum number of measured values returned is:</p> <p>13 modulation offsets + 0 Hz carrier 4 switching offsets + 0 Hz carrier</p>
<p>Multiple Offsets Modulation Sweep Mode</p>	<p>n=1 (or not specified)</p>	<p>Returns 5 measurement results of the closest point to the limit line:</p> <ol style="list-style-type: none"> 1. Frequency 2. Offset frequency from carrier frequency 3. Power in dBm 4. delta from limit (dB) 5. delta from reference (dB)
<p>Single Offset</p>	<p>2</p>	<p>Returns floating point numbers (in dBm) of the captured trace data. It contains N data points of the “spectrum due to modulation” signal, where N is the specified number of samples.</p>

MEASure Group of Commands

Measurement Method	n	Results Returned
Single Offset	3	Returns floating point numbers (in dBm) of the captured trace data. It contains N data points of the “spectrum due to switching transients” signal, where N is the specified number of samples.
Multiple Offsets Modulation, Sweep Mode	4	Returns floating point numbers (in dBm) of the sweep spectrum of modulation.
Multiple Offsets Modulation, Sweep Mode	5	Returns floating point numbers (in dBm) of the limit trace.

Power Control (PRACH) Measurement

This provides a PRACH power profile measurement for waveform or chip power measurement results.

The general functionality of CONFigure, FETCh, MEASure, and READ are described at the beginning of this section. See the SENSE:CDPower commands for more measurement related commands.

:CONFigure:PCONTrol

:FETCh:PCONTrol[n]?

:READ:PCONTrol[n]?

:MEASure:PCONTrol[n]?

Front Panel

Access: Meas Setup, Meas Type

Measurement Results Available

n	Results Returned
0	Returns unprocessed I/Q trace data, as a series of comma-separated range point values, in volts.
n=1 (or not specified)	Returns the following 3 comma-separated scalar results in the following order: <ol style="list-style-type: none"> 1. Number of slots is an integer number of the number of slots found in the captured data. (In case of PRACH measurement, it always returns 0). 2. Number of PRACH preamble is an integer number to give the number of PRACH preamble burst found in captured data. (In case of Slot measurement, it always returns 0). 3. Number of PRACH Message is an integer number to give the number of PRACH Message found in captured data. (In case of Slot measurement, it always returns 0) This number must be 1 or 0, because once PRACH Message is found, no more PRACH burst search is performed after PRACH Message burst..
2	Waveform/Chip Power trace data. Returns comma-separated waveform or chip power trace data (in dBm).
3	Slot Power Measurement trace (Absolute Power Measurement) – returns comma-separated post-processed data trace for measured data. With "Slot Power Measurement" selected, the slot averaged data trace (in dBm) will be returned. (This data trace corresponds 'Result' column in Result Number of slot is given as 1st parameter in :MEASure:PCONTrol?.

n	Results Returned
4	<p>PRACH Power result – returns comma-separated post-processed data</p> <p>Npreamble: Number of PRACH Preamble</p> <p>1st number: Pre-Burst Off Pwr (float, in dBm) of 1st PRACH preamble 2nd number: Burst On Pwr (float, in dBm) of 1st PRACH preamble 3rd number: Burst On Pwr relative to the previous data (float, in dB) of 1st PRACH (This returns always 0.0) 4th number: Post-Burst Off Pwr (float, in dBm) of 1st PRACH preamble 5th number: Time Offset (float, in chip) of 1st PRACH preamble This returns always 0.0)</p> <p>...</p> <p>(N-1)*5+1: Pre-Burst Off Pwr (float, in dBm) of Nth PRACH preamble (N-1)*5+2: Burst On Pwr (float, in dBm) of Nth PRACH preamble (N-1)*5+3: Burst On Pwr relative to the previous data (float, in dB) of Nth PRACH preamble (N-1)*5+4: Post-Burst Off Pwr (float, in dBm) of Nth PRACH preamble N*5: Time Offset (float, in chip) of Nth PRACH preamble</p> <p>...</p> <p>(Npreamble -1)*5+1: Pre-Burst Off Pwr (float, in dBm) of Npreambleth PRACH preamble (Npreamble -1)*5+2: Burst On Pwr (float, in dBm) of Npreambleth PRACH preamble (Npreamble -1)*5+3: Burst On Pwr relative to the previous data (float, in dB) of Npreambleth PRACH preamble (Npreamble -1)*5+4: Post-Burst Off Pwr (float, in dBm) of Npreambleth PRACH preamble Npreamble*5: Time Offset (float, in chip) of Npreambleth PRACH preamble Npreamble*5+1: Pre-Burst Off Pwr (float, in dBm) of PRACH Message (if available) Npreamble*5+2: Burst On Pwr (float, in dBm) of PRACH Message (if available) Npreamble*5+3: Burst On Pwr relative to the previous data (float, in dB) PRACH Message (if available) Npreamble*5+4: Post-Burst Off Pwr (float, in dBm) of PRACH Message (if available) Npreamble*5+5: Time Offset (float, in dBm) of PRACH Message (if available)</p>
5	<p>Slot Power Measurement trace (Relative Power measurement -1) – returns comma-separated post-processed data trace for measured data. With "Slot Power Measurement" selected, the relative power with the previous slot data trace (in dB) will be returned. (This data trace corresponds 'Delta Adj Pwr' column in Result window.) The first data returns always '0.0'.</p> <p>Number of slot is given as 1st parameter in :MEASure:PCONTrol?.</p>

n	Results Returned
6	<p>Slot Power Measurement trace (Relative Power Measurement – 2) – returns comma-separated post-processed data trace for measured data. With "Slot Power Measurement" selected, the relative power level with the first slot (in dB) will be returned. (This data trace corresponds to the 'Rel Pwr' column in the Results window.) The first data returns always '0.0'.</p> <p>The number of slots is the first parameter from :MEASure:PCONTrol?.</p>

Phase & Frequency Error Measurement

This measures the modulation quality of the transmitter by checking phase and frequency accuracy. You must be in the EDGE, GSM mode to use these commands. Use INSTRument:SElect to set the mode.

The general functionality of CONFigure, FETCh, MEASure, and READ are described at the beginning of this section. See the SENSE:PFERror commands for more measurement related commands.

```
:CONFigure:PFERror
:INITiate:PFERror?
:FETCh:PFERror[n]?
:READ:PFERror[n]?
:MEASure:PFERror[n]?
```

Front Panel

Access: **Measure, Phase & Freq**

After the measurement is selected, press **Restore Meas Defaults** to restore factory defaults.

Measurement Results Available

n	Results Returned
0	Returns unprocessed I/Q trace data, as a series of trace point values, in volts. The I values are listed first in each pair, using the 0 through even-indexed values. The Q values are the odd-indexed values,

n	Results Returned
n=1 (or not specified)	<p>Returns the following scalar results:</p> <ol style="list-style-type: none"> 1. RMS phase error is a floating point number (in degrees) of the rms phase error between the measured phase and the ideal phase. The calculation is based on symbol decision points and points halfway between symbol decision points (i.e. 2 points/symbol). If averaging is on, this is the average of the individual rms measurements. 2. Peak phase error is a floating point number (in degrees) of the peak phase error of all the symbol decision points. rms averaging does not affect this calculation. 3. Peak phase symbol is a floating point number (in symbols) representing the symbol number at which the peak phase error occurred. Averaging does not affect this calculation. 4. Frequency error is a floating point number (in Hz) of the frequency error in the measured signal. This is the difference between the measured phase trajectory and the reference phase trajectory. 5. I/Q origin offset is a floating point number (in dB) of the I and Q error (magnitude squared) offset from the origin. 6. Phase sample is a floating point number (in units of bits) representing the time between samples. It is used in querying phase error vector traces. 7. Bit 0 offset is an integer number for the sample point in a phase error vector trace that represents the bit 0 (zero) decision point. The sample points in the trace are numbered 0 to N. 8. Sync start is an integer number for the bit number, within the data bits trace, that represents the start of the sync word. 9. Time sample is a floating point number (in seconds) of the time between samples. It is used in querying time domain traces. For the n=0 trace, of acquired I/Q pairs, this is the time between pairs.
2, and Multi View is the selected view	Returns a series of floating point numbers (in degrees) that represent each sample in the phase error trace. The first number is the symbol 0 decision point and there are 10 points per symbol. Therefore, decision points are at 0, 10, 20, etc.
3, and Multi View is the selected view	Returns a series of floating point numbers (in degrees) that represent each sample in the phase error with frequency trace. Phase error with frequency is the error vector between the measured phase (that has not had frequency compensation) and the ideal reference phase. The calculation is based on symbol decision points and points halfway between symbol decision points (i.e. 2 points/symbol). The first number is the symbol 0 decision point and there are 10 points per symbol. Therefore, decision points are at 0, 10, 20, etc.
4, and Multi View is the selected view	Returns a series of floating point numbers that represent each sample in the log magnitude trace of the original time record. Each number represents a value (in dBm) of the time record.

n	Results Returned
<p>5, and IQ Measured Polar Vector is the selected view</p>	<p>Returns a series of floating point numbers that alternately represent I and Q pairs of the corrected measured trace. The magnitude of each I and Q pair are normalized to 1.0. The first number is the in-phase (I) sample of symbol 0 decision point and the second is the quadrature-phase (Q) sample of symbol 0 decision point. As in the rms phase error, there are ten points per symbol, so that:</p> <p>1st number = I of the symbol 0 decision point 2nd number = Q of the symbol 0 decision point .. 10th number = Q of the symbol 0 decision point 11th number = I of the symbol 1 decision point 12th number = Q of the symbol 1 decision point .. 10 × Nth number = Q of the symbol N decision point</p>
<p>6, and Multi View is the selected view</p>	<p>Returns a series of logical values (0 or 1) that represent the demodulated bit value of the measured waveform. The first number is the symbol 0 decision point and there are 10 points per symbol. Therefore, decision points are at 0, 10, 20, etc.</p>

Power Statistics CCDF Measurement

For E4406A this is a statistical power measurement of the complementary cumulative distribution function (CCDF). You must be in the Basic, cdma2000, W-CDMA, or 1xEV-DO mode to use these commands. Use INSTRument:SELEct to set the mode.

For PSA this is a statistical power measurement of the complementary cumulative distribution function (CCDF). You must be in the cdma2000, W-CDMA, or 1xEV-DO mode to use these commands. Use INSTRument:SELEct to set the mode.

The general functionality of CONFIgure, FETCh, MEASure, and READ are described at the beginning of this section. See the SENSE:PStat commands for more measurement related commands.

:CONFIgure:PStatistic

:INITiate:PStatistic

:FETCh:PStatistic[n]?

:READ:PStatistic[n]?

:MEASure:PStatistic[n]?

History: Version A.03.00 or later, added in Basic A.04.00

Front Panel

Access: **Measure, Power Stat CCDF**

After the measurement is selected, press **Restore Meas Defaults** to restore factory defaults.

Measurement Results Available

n	Results Returned
0	Returns unprocessed I/Q trace data, as a series of trace point values, in volts. The I values are listed first in each pair, using the 0 through even-indexed values. The Q values are the odd-indexed values,
n=1 (or not specified)	Returns 10 scalar results: <ol style="list-style-type: none"> 1. Average input power (in dBm) 2. Probability at the average input power level (in %) 3. Power level that has 10% of the power 4. Power level that has 1% of the power 5. Power level that has 0.1% of the power 6. Power level that has 0.01% of the power 7. Power level that has 0.001% of the power 8. Power level that has 0.0001% of the power 9. Peak power (in dB) 10. Count

n	Results Returned
2	<p>Returns a series of 5001 floating point numbers (in percent) that represent the current measured power stat trace. This is the probability at particular power levels (average power), in the following order:</p> <ol style="list-style-type: none"> 1. Probability at 0.0 dB power 2. Probability at 0.01 dB power 3. Probability at 0.02 dB power <p style="text-align: center;">. . .</p> <ol style="list-style-type: none"> 1. Probability at 49.9 dB power 2. Probability at 50.0 dB power
3	<p>Returns a series of 5001 floating point numbers (in percent) that represent the Gaussian trace. This is the probability at particular power levels (average power), in the following order:</p> <ol style="list-style-type: none"> 1. Probability at 0.0 dB power 2. Probability at 0.01 dB power 3. Probability at 0.02 dB power <p style="text-align: center;">. . .</p> <ol style="list-style-type: none"> 1. Probability at 49.9 dB power 2. Probability at 50.0 dB power
4	<p>Returns a series of 5001 floating point numbers (in percent) that represent the user-definable reference trace. This is the probability at particular power levels (average power), in the following order:</p> <ol style="list-style-type: none"> 1. Probability at 0.0 dB power 2. Probability at 0.01 dB power 3. Probability at 0.02 dB power <p style="text-align: center;">. . .</p> <ol style="list-style-type: none"> 1. Probability at 49.9 dB power 2. Probability at 50.0 dB power

Power vs. Time Measurement

For E4406A this measures the average power during the “useful part” of the burst comparing the power ramp to required timing mask. You must be in EDGE, GSM, 1xEV-DO or Service mode to use these commands. Use INSTRument:SElect to set the mode.

The general functionality of CONFigure, FETCh, MEASure, and READ are described at the beginning of this section. See the SENSE:PVTime commands for more measurement related commands.

```
:CONFigure:PVTime
:INITiate:PVTime
:FETCh:PVTime[n]?
:READ:PVTime[n]?
:MEASure:PVTime[n]?
```

Front Panel

Access: **Measure, Power vs Time**

After the measurement is selected, press **Restore Meas Defaults** to restore factory defaults.

History: Modified in version A.05.00..

Measurement Results Available

n	Results Returned
0	Returns unprocessed I/Q trace data, as a series of trace point values, in volts. The I values are listed first in each pair, using the 0 through even-indexed values. The Q values are the odd-indexed values.

n	Results Returned
n=1 (or not specified)	<p>Returns the following scalar results:</p> <ol style="list-style-type: none"> 1. Sample time is a floating point number that represents the time between samples when using the trace queries (n=0,2,etc.). 2. Power of single burst is the mean power (in dBm) across the useful part of the selected burst in the most recently acquired data, or in the last data acquired at the end of a set of averages. If averaging is on, the power is for the last burst. 3. Power averaged is the power (in dBm) of N averaged bursts, if averaging is on. The power is averaged across the useful part of the burst. Average <i>m</i> is a single burst from the acquired trace. If there are multiple bursts in the acquired trace, only one burst is used for average <i>m</i>. This means that N traces are acquired to make the complete average. If averaging is off, the value of power averaged is the same as the power single burst value. 4. Number of samples is the number of data points in the captured signal. This number is useful when performing a query on the signal (i.e. when n=0,2,etc.). 5. Start point of the useful part of the burst is the index of the data point at the start of the useful part of the burst 6. Stop point of the useful part of the burst is the index of the data point at the end of the useful part of the burst 7. Index of the data point where T_0 occurred. 8. Burst width of the useful part of the burst is the width of the burst measured at -3dB below the mean power in the useful part of the burst. 9. Maximum value is the maximum value of the most recently acquired data (in dBm). 10. Minimum value is the minimum value of the most recently acquired data (in dBm). 11. Burst search threshold is the value (in dBm) of the threshold where a valid burst is identified, after the data has been acquired. 12. IQ point delta is the number of data points offset that are internally applied to the useful data in traces $n=2,3,4$. You must apply this correction value to find the actual location of the Start, Stop, or T_0 values.

n	Results Returned
n=1 (or not specified) 1xEV-DO or W-CDMA mode	<p>Returns the following scalar results:</p> <ol style="list-style-type: none"> 1. Sample time is a floating point number that represents the time between samples when using the trace queries (where n = 0, 2, etc.). 2. Power of single burst is the mean power (in dBm) across the useful part of the selected burst in the most recently acquired data, or in the last data acquired at the end of a set of averages. If averaging is on, the power is for the last burst. 3. Power averaged is the power (in dBm) of N averaged bursts, if averaging is on. The power is averaged across the useful part of the burst. Average <i>m</i> is a single burst from the acquired trace. If there are multiple bursts in the acquired trace, only one burst is used for average <i>m</i>. This means that N traces are acquired to make the complete average. If averaging is off, the value of power averaged is the same as the power single burst value. 4. Number of samples (N) is the number of data points in the captured signal. This number is useful when performing a query on the signal (i.e. when n = 0, 2, etc.). 5. Start point of the useful part of the burst is the index of the data point at the start of the useful part of the burst 6. Stop point of the useful part of the burst is the index of the data point at the end of the useful part of the burst 7. Index of the data point where T_0 occurred. 8. Burst width of the useful part of the burst is the width of the burst measured at -3dB below the mean power in the useful part of the burst. 9. Maximum value is the maximum value of the most recently acquired data (in dBm). 10. Minimum value is the minimum value of the most recently acquired data (in dBm). 11. Burst search threshold is the value (in dBm) of the threshold where a valid burst is identified, after the data has been acquired. 12. Averaged number (N) is used to average the measurement results. 13. First position in index to exceed the limit (N) is ? 14. Reserved for future use, returns -999.0. 15. Reserved for future use, returns -999.0. 16. Reserved for future use, returns -999.0. 17. Absolute power in the region A (dBm) 18. Absolute power in the region B (dBm) 19. Absolute power in the region C (dBm) 20. Absolute power in the region D (dBm) 21. Absolute power in the region E (dBm) 22. Relative power in the region A (dB) 23. Relative power in the region B (dB) 24. Relative power in the region C (dB) 25. Relative power in the region D (dB)

n	Results Returned
n=1 (or not specified) (cont.) 1xEV-DO or W-CDMA mode	<p>26. Relative power in the region E (dB)</p> <p>27. Maximum absolute power in the region A (dBm)</p> <p>28. Maximum absolute power in the region B (dBm)</p> <p>29. Maximum absolute power in the region C (dBm)</p> <p>30. Maximum absolute power in the region D (dBm)</p> <p>31. Maximum absolute power in the region E (dBm)</p> <p>32. Maximum relative power in the region A (dB)</p> <p>33. Maximum relative power in the region B (dB)</p> <p>34. Maximum relative power in the region C (dB)</p> <p>35. Maximum relative power in the region D (dB)</p> <p>36. Maximum relative power in the region E (dB)</p> <p>37. Minimum absolute power in the region A (dBm)</p> <p>38. Minimum absolute power in the region B (dBm)</p> <p>39. Minimum absolute power in the region C (dBm)</p> <p>40. Minimum absolute power in the region D (dBm)</p> <p>41. Minimum absolute power in the region E (dBm)</p> <p>42. Minimum relative power in the region A (dB)</p> <p>43. Minimum relative power in the region B (dB)</p> <p>44. Minimum relative power in the region C (dB)</p> <p>45. Minimum relative power in the region D (dB)</p> <p>46. Minimum relative power in the region E (dB)</p>
2	Returns trace point values of the entire captured I/Q trace data. These data points are floating point numbers representing the power of the signal (in dBm). There are N data points, where N is the number of samples . The period between the samples is defined by the sample time .
3	Returns data points representing the upper mask (in dBm).
4	Returns data points representing the lower mask (in dBm).
6 W-CDMA mode	Returns 5 comma-separated scalar values of the pass/fail (0.0=passed, or 1.0=failed) results determined by testing the upper mask.
7 W-CDMA mode	Returns 5 comma-separated scalar values of the pass/fail (0.0=passed, or 1.0=failed) results determined by testing the lower mask:
7 EDGE, GSM, Service mode (E4406A only)	Returns power level values for the 8 slots in the current frame (in dBm).

Modulation Accuracy (Rho) Measurement

This measures the modulation accuracy of the transmitter by checking the magnitude and phase error and the EVM (error vector magnitude). You must be in the cdmaOne, cdma2000, W-CDMA, or 1xEV-DO mode to use these commands. Use INSTRument:SElect to set the mode.

For 1xEV-DO: these commands will measure modulation accuracy on network access equipment (base transmitter stations). Use MEAS:TRHO to measure terminal transmitter modulation accuracy, after selecting mobile stations using SENSE:RADio:DEvIce MS.

The general functionality of CONFigure, FETCh, MEASure, and READ are described at the beginning of this section. See the SENSE:RHO commands for more measurement related commands.

:CONFigure:RHO

:INITiate:RHO

:FETCh:RHO[n]?

:READ:RHO[n]?

:MEASure:RHO[n]?

Front Panel

Access: **Measure, Mod Accuracy (Rho) for cdmaOne**

Measure, Mod Accuracy (Composite Rho) for cdma2000, 1xEV-DO, or W-CDMA (3GPP)

After the measurement is selected, press **Restore Meas Defaults** to restore factory defaults.

Measurement Results Available

n	Results Returned
0 cdmaOne mode	Returns unprocessed I/Q trace data, as a series of trace point values. The I values are listed first in each pair, using the 0 through even-indexed values. The Q values are the odd-indexed values. The standard sample rate is 7.5 MHz and the trace length is determined by the current measurement interval.
0 cdma2000 or W-CDMA mode	Returns unprocessed I/Q trace data, as a series of trace point values. The I values are listed first in each pair, using the 0 through even-indexed values. The Q values are the odd-indexed values.

n	Results Returned
n=1 (or not specified) cdmaOne mode	<p>Returns 7 floating point numbers, in the following order:</p> <ol style="list-style-type: none"> 1. Rho (no units) represents the correlation of the measured power compared to the ideal pilot channel. The calculation is performed after the complementary filter, so it is IS95 compliant. It is performed at the decision points in the pilot waveform. If averaging is on, this is the average of the individual rms measurements. 2. Time offset (with units of seconds) is the time delay of the even second clock with respect to the start of the short code PN sequences, at offsets from the 15 zeros in the characteristic phase of the sequence. 3. Frequency error of the measured signal, with units of Hz. This is based on the linear best fit of the uncorrected measured phase. 4. Carrier feedthrough has units of dB and is the dc error offset of I and Q, from the origin. 5. EVM has units of percent. The calculation is based on the composite of the phase error and magnitude error, between the measured signal and the ideal pilot channel. It is performed after the complementary filter which removes the inter-symbol interference in the modulated data. If averaging is on, this is the average of the individual rms measurements. 6. Magnitude error (with units of percent) is the rms error between the measured (compensated) magnitude and the ideal magnitude. This is performed after the complementary filter which removes the inter-symbol interference in the modulated data. If averaging is on, this is the average of the individual rms measurements. 7. Phase error (with units in percent) is the rms phase error between the measured phase and the ideal phase. The calculation is performed after the complementary filter which removes the inter-symbol interference in the modulated data. If averaging is on, this is the average of the individual rms measurements.

n	Results Returned
n=1 (or not specified) cdma2000	<p>Returns 11 scalar results, in the following order.</p> <ol style="list-style-type: none"> 1. RMS EVM is a floating point number (in percent) of EVM over the entire measurement area 2. Peak EVM is a floating point number (in percent) of peak EVM in the measurement area 3. Magnitude error is a floating point number (in percent) of average magnitude error over the entire measurement area 4. Phase error is a floating point number (in degree) of average phase error over the entire measurement area 5. I/Q origin offset is a floating point number (in dB) of the I and Q error (magnitude squared) offset from the origin 6. Frequency error is a floating point number (in Hz) of the frequency error in the measured signal 7. Rho is a floating point number of Rho 8. Peak code domain error is a floating point number (in dB) of the Peak Code Domain Error relative to the mean power 9. Peak code domain error channel number is the channel number in which the peak code domain error is detected at the max spreading factor. <p>NOTE: For MS measurements of Q channel numbers, subtract 32 from the number returned by SCPI query to obtain the actual channel number. For example, if the front panel displayed result is "W32(15):Q", then the SCPI query result will be "47". As $47 - 32 = 15$, 15 is the actual Peak CDE channel number result.</p> <p>For I channel MS measurements, as well as both I and Q channel BTS measurements, the returned number is the actual Peak CDE channel number.</p> <ol style="list-style-type: none"> 10. Number of active channels. 11. Time offset is a floating point number (in second) PN offset from the trigger point.

n	Results Returned
<p>n=1 (or not specified) W-CDMA mode</p>	<p>Returns following 13 scalar results, in the following order.</p> <ol style="list-style-type: none"> 1. RMS EVM is a floating point number (in percent) of EVM over the entire measurement area 2. Peak EVM error is a floating point number (in percent) of peak EVM in the measurement area 3. Magnitude error is a floating point number (in percent) of average magnitude error over the entire measurement area 4. Phase error is a floating point number (in degree) of average phase error over the entire measurement area 5. I/Q origin offset is a floating point number (in dB) of the I and Q error (magnitude squared) offset from the origin 6. Frequency error is a floating point number (in Hz) of the frequency error in the measured signal 7. Rho is a floating point number of Rho 8. Peak Code Domain Error is a floating point number (in dB) of the Peak Code Domain Error relative to the mean power 9. Peak Code Domain Error Channel Number is the channel number in which the peak code domain error is detected at the max spreading factor. 10. Number of active channels. 11. Time offset is a floating point number (in chip) of the pilot phase timing from the acquisition trigger point. 12. CPICH power over a slot is a floating point number in dB of CPICH power over a measurement slot. In the MS mode the value returned is -999. 13. Average total power over a slot is a floating point number in dB of total RF power over a measurement slot.
<p>n=1 (or not specified) 1xEV-DO mode For base stations: SENS:RAD:DEV BTS For meas type: CALC:RHO:TYPE DATA MAC PILot PReamble</p>	<p>Returns up to the following 31 comma-separated scalar results, in the following order:</p> <p>Returns ONLY the following 9 comma-separated scalar results, in the following order, for base transmitter station measurements when the type is <i>NOT</i> set to ALL:</p> <ol style="list-style-type: none"> 1. RMS EVM – a floating point number (in percent) of EVM over the entire measurement area. 2. Peak EVM error – a floating point number (in percent) of peak EVM in the measurement area. 3. Magnitude error – a floating point number (in percent) of average magnitude error over the entire measurement area. 4. Phase error – a floating point number (in degree) of average phase error over the entire measurement area. 5. I/Q Origin Offset – a floating point number (in dB) of the I and Q error (magnitude squared) offset from the origin. 6. Frequency error – a floating point number (in Hz) of the frequency error in the measured signal. 7. Rho – a floating point number of Rho. 8. Number of active channels. 9. Time offset is the time from the trigger to the PN offset – a floating point number (in micro seconds) of PN offset from the trigger point.

n	Results Returned
<p>n=1 (or not specified)</p> <p>1xEV-DO mode</p> <p>For base stations: SENS:RAD:DEV BTS</p> <p>For meas type ALL: CALC:RHO:TYPE ALL</p>	<p>Returns the following 17 scalar results for base transmitter station measurements when the type is set to ALL.</p> <p>Rho Overall-1 and Rho Overall-2 specified in 3GPP2 TSG-C4.1 Recommended Minimum Performance Standard for cdma2000 High Rate Data Packet Access Network, 11.4.2 Waveform Quality Measurement section.</p> <ol style="list-style-type: none"> 10. RMS EVM (Overall-1) – a floating point number (in percent) of EVM over the entire measurement area. 11. Peak EVM error (Overall-1) – a floating point number (in percent) of peak EVM in the measurement area. 12. Magnitude error (Overall-1) – a floating point number (in percent) of average magnitude error over the entire measurement area. 13. Phase error (Overall-1) – a floating point number (in degree) of average phase error over the entire measurement area. 14. I/Q Origin Offset (Overall-1) – a floating point number (in dB) of the I and Q error (magnitude squared) offset from the origin. 15. Frequency error (Overall-1) – a floating point number (in Hz) of the frequency error in the measured signal. 16. Rho (Overall-1) – a floating point number of Rho. 17. RMS EVM (Overall-2) – a floating point number (in percent) of EVM over the entire measurement area. 18. Peak EVM error (Overall-2) – a floating point number (in percent) of peak EVM in the measurement area. 19. Magnitude error (Overall-2) – a floating point number (in percent) of average magnitude error over the entire measurement area. 20. Phase error (Overall-2) – a floating point number (in degree) of average phase error over the entire measurement area. 21. I/Q Origin Offset (Overall-2) – a floating point number (in dB) of the I and Q error (magnitude squared) offset from the origin. 22. Frequency error (Overall-2) – a floating point number (in Hz) of the frequency error in the measured signal. 23. Rho (Overall-2) – a floating point number of Rho. 24. Number of active channels in Pilot 25. Number of active channels in Mac 26. Number of active channels in Data 27. Preamble Length 28. MAC Index 29. Number of Max MAC Inactive channel Power – a floating point number (in dB) of Maximum MAC Inactive Channel Power channels in Data 30. Max Data Active Channel Power – a floating point number (in dB) of Maximum Data Active Channel Power 31. Min Data Active Channel Power – a floating point number (in dB) of Minimum Data Active Channel Power

n	Results Returned
2 cdmaOne mode	EVM trace – returns error vector magnitude (EVM) data, as trace point values in percent. The first value is the chip 0 decision point. The trace is interpolated for the currently selected points/chips displayed on the front panel. The number of trace points depends on the current measurement interval setting.
2 cdma2000 or W-CDMA mode	EVM trace – returns series of floating point numbers (in percent) that represent each sample in the EVM trace. The first number is the symbol 0 decision point. There are X points per symbol ($X = \text{points/chip}$). Therefore, the decision points are at $0, 1 \times X, 2 \times X, 3 \times X \dots$
2 1xEV-DO mode	Returns series of floating point numbers (in percent) that represent each sample in the EVM trace. The first number is the symbol 0 decision point and there are X points per symbol. Therefore, the decision points are at $0, 1xX, 2xX, 3xX\dots$ ($X = \text{the number of points per chip}$) This traces is available when the Measurement Channel Type Selection is Pilot, MAC or Data (CALCulate:RHO:TYPE = PILot MAC DATA) In all cases, returns one full slot data points, but only portion of EVM computation is performed are valid. All other portion is 0.0
3 cdmaOne mode	Magnitude error trace – returns magnitude error data, as trace point values, in percent. The first value is the chip 0 decision point. The trace is interpolated for the currently selected points/chips displayed on the front panel. The number of trace points depends on the current measurement interval setting.
3 cdma2000, W-CDMA, or 1xEV-DO mode	Magnitude error trace – returns series of floating point numbers (in percent) that represent each sample in the magnitude error trace. The first number is the symbol 0 decision point. There are X points per symbol ($X = \text{points/chip}$). Therefore, the decision points are at $0, 1 \times X, 2 \times X, 3 \times X \dots$ For 1xEV-DO: this traces is available when the Measurement Channel Type Selection is Pilot, MAC or Data (CALCulate:RHO:TYPE = PILot MAC DATA) In all cases, returns one full slot data points, but only portion of EVM computation is performed are valid. All other portion is 0.0
4 cdmaOne mode	Phase error trace – returns phase error data, as trace point values, in degrees. The first value is the symbol 0 decision point. The trace is interpolated for the currently selected chips/symbol displayed on the front panel. The number of trace points depends on the current measurement interval setting.

n	Results Returned
<p>4</p> <p>cdma2000, W-CDMA, or 1xEV-DO mode</p>	<p>Phase error trace – returns series of floating point numbers (in degrees) that represent each sample in the phase error trace. There are X points per symbol ($X = \text{points/chip}$). Therefore, the decision points are at $0, 1 \times X, 2 \times X, 3 \times X \dots$</p> <p>For 1xEV-DO: this traces is available when the Measurement Channel Type Selection is Pilot, MAC or Data (CALCulate:RHO:TYPE = PILOt MAC DATA) In all cases, returns one full slot data points, but only portion of EVM computation is performed are valid. All other portion is 0.0</p>
<p>5</p> <p>cdmaOne mode</p>	<p>Corrected measured data – returns a series of floating point numbers that alternately represent I and Q pairs of the corrected measured trace data. The magnitude of each I and Q pair are normalized to 1.0.</p> <p>The number of trace points depends on the current measurement interval setting.</p> <p>The numbers are sent in the following order:</p> <p style="padding-left: 40px;">In-phase (I) sample, of symbol 0 decision point Quadrature-phase (Q) sample, of symbol 0 decision point ... In-phase (I) sample, of symbol 1 decision point Quadrature-phase (Q) sample, of symbol 1 decision point ...</p> <p>The trace can be interpolated to 2,4, 8 points/chip selected with the display Points/Chip softkey. This will change the number of points between decision points in the trace, changing the number of I/Q pairs sent for each decision point.</p>
<p>5</p> <p>cdma2000, W-CDMA, 1xEV-DO mode</p>	<p>Corrected measured trace – returns series of floating point numbers that alternately represent I and Q pairs of the corrected measured trace. The magnitude of each I and Q pair are normalized to 1.0. The first number is the in-phase (I) sample of symbol 0 decision point and the second is the quadrature-phase (Q) sample of symbol 0 decision point. There are X points per symbol ($X = \text{points/chip}$), so the series of numbers is:</p> <p style="padding-left: 40px;">1st number = I of the symbol 0 decision point 2nd number = Q of the symbol 0 decision point ... $(2 \times X) + 1$, number = I of the symbol 1 decision point $(2 \times X) + 2$, number = Q of the symbol 1 decision point ... $(2 \times X) \times Nth + 1$ number = I of the symbol N decision point $(2 \times X) \times Nth + 2$ number = Q of the symbol N decision point</p> <p>For 1xEV-DO: this traces is available when the Measurement Channel Type Selection is Pilot, MAC or Data (CALCulate:RHO:TYPE = PILOt MAC DATA) In all cases, returns one full slot data points, but only portion of EVM computation is performed are valid. All other portion is 0.0</p>

n	Results Returned
6 cdmaOne mode	<p>Reference IQ data – returns a series of floating point numbers that alternately represent I and Q pairs of the reference trace data.</p> <p>The number of trace points depends on the current measurement interval and points per chip settings.</p> <p>The numbers are sent in the following order:</p> <p style="padding-left: 40px;">In-phase (I) sample, of symbol 0 decision point Quadrature-phase (Q) sample, of symbol 0 decision point ... In-phase (I) sample, of symbol 1 decision point Quadrature-phase (Q) sample, of symbol 1 decision point ...</p> <p>The trace can be interpolated to 2,4,8 points/chip selected with the display Points/Chip softkey.</p>
6 cdma2000 mode	<p>Returns 6 scalar values of the pass/fail (0=passed, or 1=failed) results determined by testing the EVM and peak EVM.</p> <ol style="list-style-type: none"> 1. Test result of EVM 2. Test result of Peak EVM 3. Test result of Rho 4. Test result of Peak Code Domain Error 5. Test result of Time Offset 6. Test result of Phase Error
6 1xEV-DO mode	<p>The same as n=2. (Overall-1)</p> <p>This trace is available when the Measurement Channel Type Selection is All (CALCulate:RHO:TYPE = ALL)</p> <p>(Rho Overall-1 and Rho Overall-2 as specified in 3GPP2 TSG-C4.1 Recommended Minimum Performance Standard for cdma2000 High Rate Data Packet Access Network, 11.4.2 Waveform Quality Measurement section.)</p> <p>n=6, 7, 8, 9 are for Overall-1 data trace n=10, 11, 12, 13 are for Overall-2 data trace</p> <p>In all cases, returns one full slot data points, but only portion of EVM computation is performed are valid. All other portion is 0.0</p>
6 W-CDMA mode	<p>Returns 6 comma-separated scalar values of the pass/fail (0.0 = passed, or 1.0 = failed) results determined by testing the EVM and peak EVM.</p> <ol style="list-style-type: none"> 1. Test result of EVM 2. Test result of Peak EVM 3. Test result of Rho 4. Test result of Peak Code Domain Error 5. Test result of Frequency Error 6. Test result of CPICH power over a frame (If MS is selected, this always returns 0.0.)

n	Results Returned
7 cdmaOne mode	<p>complementary filtered measured data – returns a series of floating point numbers that alternately represent I and Q pairs of the complementary filtered measured data. This is inverse filtered data of the inter-symbol interference in CDMA signals due to the digital transmission filters defined in the standard as well as the base station phase equalization filter.</p> <p>The number of trace points depends on the current measurement interval setting.</p> <p>The numbers are sent in the following order:</p> <p style="padding-left: 40px;">In-phase (I) sample, of symbol 0 decision point Quadrature-phase (Q) sample, of symbol 0 decision point ... In-phase (I) sample, of symbol 1 decision point Quadrature-phase (Q) sample, of symbol 1 decision point ...</p> <p>The trace can be interpolated to 2,4,8 points/chip selected with the display Points/Chip softkey. This will change the number of points between decision points in the trace, changing the number of I/Q pairs sent for each decision point.</p>
7 cdma2000 mode	<p>Returns series of floating point numbers of code level, code index, power (in dB), time offset (in ns), phase offset (in rad), and code domain error (in dB). The total number of results are six times of “number of active channels”. The number of active channels can be obtained by the 10th result of <code>FETCH:RHO0</code> command.</p>
7 1xEV-DO mode	<p>The same as n=3. (Overall-1)</p> <p>This trace is available when the Measurement Channel Type Selection is All (CALCulate:RHO:TYPE = ALL)</p> <p>(Rho Overall-1 and Rho Overall-2 as specified in 3GPP2 TSG-C4.1 Recommended Minimum Performance Standard for cdma2000 High Rate Data Packet Access Network, 11.4.2 Waveform Quality Measurement section.)</p> <p>n=6, 7, 8, 9 are for Overall-1 data trace n=10, 11, 12, 13 are for Overall-2 data trace</p> <p>In all cases, returns one full slot data points, but only portion of EVM computation is performed are valid. All other portion is 0.0</p>

n	Results Returned
<p>7 W-CDMA mode</p>	<p>With a device of BTS, it returns a series of floating point numbers: symbol rate (ex. 7.5 ksps), OVVSF code number, a dummy value, power level and code domain error for the active channels.</p> <p>With a device of MS, it returns a series of floating point numbers: symbol rate (ex. 15 ksps), OVVSF code number, 1.0 (I) or -1.0 (Q), power level and code domain error for the active channels. The results would look like the following:</p> <p>1st number = Symbol Rate for 1st Active Channel 2nd number = OVVSF Code number for 1st Active Channel 3rd number = (in BTS) -999, or (in MS) either +1 (I) or -1 (Q) for 1st Active Channel 4th number = Power Level (in dB) for 1st Active Channel 5th number = Code Domain Error for 1st Active Channel ... (N-1)*5+1 number = Symbol Rate for Nth Active Channel (N-1)*5+2 number = OVVSF Code number for Nth Active Channel (N-1)*5+3 number = -999 (in BTS), or either +1 (I) or -1 (Q) (in MS) for Nth Active Channel (N-1)*5+4 number = Power Level (in dB) for Nth Active Channel N*5 number = Code Domain Error for Nth Active Channel</p> <p>Number of active channel is given by 10th parameter of :MEASure:RHO[1].</p>
<p>8 cdmaOne mode</p>	<p>complementary filtered reference data – returns a series of floating point numbers that alternately represent I and Q pairs of the complementary filtered reference data. This is inverse filtered data of the inter-symbol interference in CDMA signals due to the digital transmission filters defined in the standard as well as the base station phase equalization filter.</p> <p>The number of trace points depends on the current measurement interval setting.</p> <p>The numbers are sent in the following order:</p> <p>In-phase (I) sample, of symbol 0 decision point Quadrature-phase (Q) sample, of symbol 0 decision point ... In-phase (I) sample, of symbol 1 decision point Quadrature-phase (Q) sample, of symbol 1 decision point ...</p> <p>The trace can be interpolated to 2,4,8 points/chip selected with the display Points/Chip softkey. This will change the number of points between decision points in the trace, changing the number of I/Q pairs sent for each decision point.</p>

n	Results Returned
<p>8 W-CDMA mode</p>	<p>Returns a series of floating point numbers (in dB) that represents all the code domain powers.</p> <p>With a device of BTS, there are 512 numbers. If the active channel occupies more than the max spreading factor (7.5 ksps) the power is duplicated (active symbol rate/7.5 ksps) times.</p> <p>1st number = 1st code power over the slot 2nd number = 2nd code power over the slot ... Nth number = Nth code power over the slot</p> <p>With a device of MS, there are 256 I/Q pairs. If the active channel occupies more than the max spreading factor (15 ksps) the power is duplicated (active symbol rate / 15 ksps) times.</p> <p>1st number = 1st in-phase code power over the slot 2nd number = 1st quad-phase code power over the slot ... (2*N-1) number = Nth in-phase code power over the slot (2 *N) number = Nth quad-phase code power over a slot</p> <p>N = the number of codes detected. The total number of codes varies because of the different symbol rates of each code.</p>
<p>8 1xEV-DO mode</p>	<p>The same as n=4. (Overall-1)</p> <p>This trace is available when the Measurement Channel Type Selection is All (CALCulate:RHO:TYPE = ALL)</p> <p>(Rho Overall-1 and Rho Overall-2 as specified in 3GPP2 TSG-C4.1 Recommended Minimum Performance Standard for cdma2000 High Rate Data Packet Access Network, 11.4.2 Waveform Quality Measurement section.)</p> <p>n=6, 7, 8, 9 are for Overall-1 data trace n=10, 11, 12, 13 are for Overall-2 data trace</p> <p>In all cases, returns one full slot data points, but only portion of EVM computation is performed are valid. All other portion is 0.0</p>

n	Results Returned
<p>9 1xEV-DO mode</p>	<p>The same as n=5. (Overall-1)</p> <p>This trace is available when the Measurement Channel Type Selection is All (CALCulate:RHO:TYPE = ALL)</p> <p>(Rho Overall-1 and Rho Overall-2 as specified in 3GPP2 TSG-C4.1 Recommended Minimum Performance Standard for cdma2000 High Rate Data Packet Access Network, 11.4.2 Waveform Quality Measurement section.)</p> <p>n=6, 7, 8, 9 are for Overall-1 data trace n=10, 11, 12, 13 are for Overall-2 data trace</p> <p>In all cases, returns one full slot data points, but only portion of EVM computation is performed are valid. All other portion is 0.0</p>
<p>10 1xEV-DO mode</p>	<p>The same as n=2. (Overall-2)</p> <p>This trace is available when the Measurement Channel Type Selection is All (CALCulate:RHO:TYPE = ALL)</p> <p>(Rho Overall-1 and Rho Overall-2 as specified in 3GPP2 TSG-C4.1 Recommended Minimum Performance Standard for cdma2000 High Rate Data Packet Access Network, 11.4.2 Waveform Quality Measurement section.)</p> <p>n=6, 7, 8, 9 are for Overall-1 data trace n=10, 11, 12, 13 are for Overall-2 data trace</p> <p>In all cases, returns one full slot data points, but only portion of EVM computation is performed are valid. All other portion is 0.0</p>
<p>11 cdmaOne mode</p>	<p>Corrected measured data – returns a series of floating point numbers that alternately represent I and Q pairs of the corrected measured trace data. The magnitude of each I and Q pair are normalized to 1.0.</p> <p>The number of trace points depends on the current setting for the number of displayed I/Q points in the I/Q display.</p> <p>The numbers are sent in the following order:</p> <p style="padding-left: 40px;">In-phase (I) sample, of symbol 0 decision point Quadrature-phase (Q) sample, of symbol 0 decision point ... In-phase (I) sample, of symbol 1 decision point Quadrature-phase (Q) sample, of symbol 1 decision point ...</p> <p>The trace can be interpolated to 2,4,8 points/chip selected with the display Points/Chip softkey. This will change the number of points between decision points in the trace, changing the number of I/Q pairs sent for each decision point.</p>

n	Results Returned
<p>11</p> <p>1xEV-DO mode</p>	<p>The same as n=2. (Overall-2)</p> <p>This trace is available when the Measurement Channel Type Selection is All</p> <p>(CALCulate:RHO:TYPE = ALL)</p> <p>(Rho Overall-1 and Rho Overall-2 as specified in 3GPP2 TSG-C4.1 Recommended Minimum Performance Standard for cdma2000 High Rate Data Packet Access Network, 11.4.2 Waveform Quality Measurement section.)</p> <p>n=6, 7, 8, 9 are for Overall-1 data trace</p> <p>n=10, 11, 12, 13 are for Overall-2 data trace</p> <p>In all cases, returns one full slot data points, but only portion of EVM computation is performed are valid. All other portion is 0.0</p>
<p>12</p> <p>1xEV-DO mode</p>	<p>The same as n=4. (Overall-2)</p> <p>This trace is available when the Measurement Channel Type Selection is All</p> <p>(CALCulate:RHO:TYPE = ALL)</p> <p>(Rho Overall-1 and Rho Overall-2 as specified in 3GPP2 TSG-C4.1 Recommended Minimum Performance Standard for cdma2000 High Rate Data Packet Access Network, 11.4.2 Waveform Quality Measurement section.)</p> <p>n=6, 7, 8, 9 are for Overall-1 data trace</p> <p>n=10, 11, 12, 13 are for Overall-2 data trace</p> <p>In all cases, returns one full slot data points, but only portion of EVM computation is performed are valid. All other portion is 0.0</p>

n	Results Returned
<p>13 cdmaOne mode</p>	<p>complementary filtered measured data – returns a series of floating point numbers that alternately represent I and Q pairs of the complementary filtered measured data. This is inverse filtered data of the inter-symbol interference in CDMA signals due to the digital transmission filters defined in the standard as well as the base station phase equalization filter.</p> <p>The number of trace points depends on the current setting for the number of displayed I/Q points in the I/Q display.</p> <p>The numbers are sent in the following order:</p> <p style="padding-left: 40px;">In-phase (I) sample, of symbol 0 decision point Quadrature-phase (Q) sample, of symbol 0 decision point ... In-phase (I) sample, of symbol 1 decision point Quadrature-phase (Q) sample, of symbol 1 decision point ...</p> <p>The trace can be interpolated to 2,4,8 points/chip selected with the display Points/Chip softkey. This will change the number of points between decision points in the trace, changing the number of I/Q pairs sent for each decision point.</p>
<p>13 1xEV-DO mode</p>	<p>The same as n=5. (Overall-2)</p> <p>This trace is available when the Measurement Channel Type Selection is All (CALCulate:RHO:TYPE = ALL)</p> <p>(Rho Overall-1 and Rho Overall-2 as specified in 3GPP2 TSG-C4.1 Recommended Minimum Performance Standard for cdma2000 High Rate Data Packet Access Network, 11.4.2 Waveform Quality Measurement section.)</p> <p>n=6, 7, 8, 9 are for Overall-1 data trace n=10, 11, 12, 13 are for Overall-2 data trace</p> <p>In all cases, returns one full slot data points, but only portion of EVM computation is performed are valid. All other portion is 0.0</p>

n	Results Returned
14 1xEV-DO mode	<p>The same as n=5. (Overall-2) I/Q trace data is descrambled.</p> <p>This trace is available when the Measurement Channel Type Selection is All (CALCulate:RHO:TYPE = ALL)</p> <p>(Rho Overall-1 and Rho Overall-2 as specified in 3GPP2 TSG-C4.1 Recommended Minimum Performance Standard for cdma2000 High Rate Data Packet Access Network, 11.4.2 Waveform Quality Measurement section.)</p> <p>n=6, 7, 8, 9 are for Overall-1 data trace n=10, 11, 12, 13 are for Overall-2 data trace</p> <p>In all cases, returns one full slot data points, but only portion of EVM computation is performed are valid. All other portion is 0.0</p>
15 1xEV-DO mode	<p>Returns 10 comma-separated scalar values of the pass/fail (0.0=passed, or 1.0=failed) results determined by testing the EVM, Peak EVM:</p> <ol style="list-style-type: none"> 1. Test result of EVM 2. Test result of Peak EVM 3. Test result of Rho 4. Test result of Frequency Error <p>Following Timing and Phase results are valid only Multichannel Estimator is On and existence of multiple codes. When the measurement is not valid, the results are 0.0</p> <ol style="list-style-type: none"> 5. Test result of Timing 6. Test result of Phase <p>Following Pilot Offset result is valid only external trigger is selected. When the measurement is not valid, the result is 0.0</p> <ol style="list-style-type: none"> 7. Test result of Pilot Offset <p>Following three results are valid exclusively. When the measurement is not valid, the result is 0.0</p> <ol style="list-style-type: none"> 8. Test result of Max MAC Inactive Channel Power 9. Test result of Max Data Active Channel Power 10. Test result of Min Data Active Channel Power

Spurious Emissions Measurement

This measures spurious emissions levels up to five pairs of offset/region frequencies and relates them to the carrier power. You must be in the cdma2000, W-CDMA or 1xEV-DO mode to use these commands. Use INSTRument:SElect to set the mode. For 1xEV-DO mode, this command will return spurious emissions measurements or adjacent channel power measurements, depending on which setting is selected using SENSE:SEMask:SEGment:TYPE ACPr | SEMask.

The general functionality of CONFigure, FETCh, MEASure, and READ are described at the beginning of this section. See the SENSE:SEMask commands for more measurement related commands.

```
:CONFigure:SEMask
:INITiate:SEMask
:FETCh:SEMask[n]?
:READ:SEMask[n]?
:MEASure:SEMask[n]?
```

Front Panel

Access: **Measure, Spectrum Emission Mask**

After the measurement is selected, press **Restore Meas Defaults** to restore factory defaults.

Measurement Results Available

Measurement Type	n	Results Returned
	0	Returns unprocessed I/Q trace data, as a series of trace point values, in volts.

Measurement Type	n	Results Returned
Total power reference	n=1 (or not specified)	<p>Returns 60 scalar results, in the following order:</p> <ol style="list-style-type: none"> 1. Reserved for future use, returns -999.0 2. Absolute power at the center frequency (reference) area (dBm) 3. Reserved for future use, returns -999.0 4. Reserved for future use, returns -999.0 5. Peak frequency in the center frequency (reference) area (Hz) 6. Reserved for future use, returns -999.0 7. Reserved for future use, returns -999.0 8. Reserved for future use, returns -999.0 9. Reserved for future use, returns -999.0 10. Reserved for future use, returns -999.0 11. Relative power on the negative offset A (dBc) 12. Absolute power on the negative offset A (dBm) 13. Relative peak power on the negative offset A (dBc) 14. Absolute peak power on the negative offset A (dBm) 15. Peak frequency in the negative offset A (Hz) 16. Relative power on the positive offset A (dBc) 17. Absolute power on the positive offset A (dBm) 18. Relative peak power on the positive offset A (dBc) 19. Absolute peak power on the positive offset A (dBm) 20. Peak frequency in the positive offset A (Hz) 21. Relative power on the negative offset B (dBc) <p style="text-align: center;">. . .</p> <ol style="list-style-type: none"> 1. Absolute peak power on the positive offset E (dBm) 2. Peak frequency in the positive offset E (Hz) <p>When [:SENSe]:SEMask:SEGMENT is set to REGION, the positive offsets are not available and return -999.0.</p>

Measurement Type	n	Results Returned
Power spectral density reference	n=1 (or not specified)	<p>Returns 60 scalar results, in the following order:</p> <ol style="list-style-type: none"> 1. Reserved for future use, returns -999.0 2. Absolute power at the center frequency (reference) area (dBm) 3. Reserved for future use, returns -999.0 4. Reserved for future use, returns -999.0 5. Peak frequency in the center frequency (reference) area (Hz) 6. Reserved for future use, returns -999.0 7. Reserved for future use, returns -999.0 8. Reserved for future use, returns -999.0 9. Reserved for future use, returns -999.0 10. Reserved for future use, returns -999.0 11. Relative power on the negative offset A (dB) 12. Absolute power on the negative offset A (dBm/Hz) 13. Relative peak power on the negative offset A (dB) 14. Absolute peak power on the negative offset A (dBm/Hz) 15. Peak frequency in the negative offset A (Hz) 16. Relative power on the positive offset A (dB) 17. Absolute power on the positive offset A (dBm/Hz) 18. Relative peak power on the positive offset A (dB) 19. Absolute peak power on the positive offset A (dBm/Hz) 20. Peak frequency in the positive offset A (Hz) 21. Relative power on the negative offset B (dB) <p style="text-align: center;">. . .</p> <ol style="list-style-type: none"> 1. Absolute peak power on the positive offset E (dBm/Hz) 2. Peak frequency in the positive offset E (Hz) <p>When [:SENSe]:SEMAsk:SEGMENT is set to REGION, the positive offsets are not available and return -999.0.</p>
	2	Returns the displayed frequency domain spectrum trace data separated by comma. The number of data is 2001 when DISPLAY:SEMAsk:VIEW is set to ALL.
	3	Returns the displayed frequency domain absolute limit trace data separated by comma. The number of data is 2001 when DISPLAY:SEMAsk:VIEW is set to ALL.
	4	Returns the displayed frequency domain relative limit trace data separated by comma. The number of data is 2001 when DISPLAY:SEMAsk:VIEW is set to ALL.

Measurement Type	n	Results Returned
Total power reference	5	<p>Returns 12 scalar values (in dBm) of the absolute power of the segment frequencies:</p> <ol style="list-style-type: none"> 1. Total power reference (dBm), for cdma2000 and W-CDMA Reserved for future use, returns -999.0, for 1xEV-DO 2. Reserved for future use, returns -999.0 3. Negative offset frequency (A) or region (A) 4. Positive offset frequency (A) <p style="text-align: center;">. . .</p> <ol style="list-style-type: none"> 1. Negative offset frequency (E) or region (E) 2. Positive offset frequency (E) <p>When [:SENSE]:SEMAsk:SEGMENT is set to REGION, the positive offsets are not available and return -999.0.</p>
Power spectral density reference	5	<p>Returns 12 scalar values (in dBm/Hz) of the absolute power of the segment frequencies:</p> <ol style="list-style-type: none"> 1. Power spectral density reference (dBm/Hz), for cdma2000 and W-CDMA Reserved for future use, returns -999.0, for 1xEV-DO 2. Reserved for future use, returns -999.0 3. Negative offset frequency (A) or region (A) 4. Positive offset frequency (A) <p style="text-align: center;">. . .</p> <ol style="list-style-type: none"> 1. Negative offset frequency (E) or region (E) 2. Positive offset frequency (E) <p>When [:SENSE]:SEMAsk:SEGMENT is set to REGION, the positive offsets are not available and return -999.0.</p>
Total power reference	6	<p>Returns 12 scalar values (in dBc) of the power relative to the carrier at the segment frequencies:</p> <ol style="list-style-type: none"> 1. Reserved for future use, returns -999.0 2. Reserved for future use, returns -999.0 3. Negative offset frequency (A) or region (A) 4. Positive offset frequency (A) <p style="text-align: center;">. . .</p> <ol style="list-style-type: none"> 1. Negative offset frequency (E) or region (E) 2. Positive offset frequency (E) <p>When [:SENSE]:SEMAsk:SEGMENT is set to REGION, the positive offsets are not available and return -999.0.</p>

Measurement Type	n	Results Returned
Power spectral density reference	6	<p>Returns 12 scalar values (in dBc) of the power relative to the carrier at the segment frequencies:</p> <ol style="list-style-type: none"> 1. Reserved for future use, returns -999.0 2. Reserved for future use, returns -999.0 3. Negative offset frequency (A) or region (A) 4. Positive offset frequency (A) <p style="text-align: center;">. . .</p> <ol style="list-style-type: none"> 1. Negative offset frequency (E) or region (E) 2. Positive offset frequency (E) <p>When [:SENSe]:SEMAsk:SEGMENT is set to REGion, the positive offsets are not available and return -999.0.</p>
	7	<p>Returns 12 pass/fail test results (0 = passed, or 1 = failed) determined by testing the absolute power of the segment frequencies:</p> <ol style="list-style-type: none"> 1. Reserved for future use, returns -999.0 2. Reserved for future use, returns -999.0 3. Negative offset frequency (A) or region (A) 4. Positive offset frequency (A) <p style="text-align: center;">. . .</p> <ol style="list-style-type: none"> 1. Negative offset frequency (E) or region (E) 2. Positive offset frequency (E) <p>When [:SENSe]:SEMAsk:SEGMENT is set to REGion, the positive offsets are not available and return -999.0.</p>
	8	<p>Returns 12 scalar values of the pass/fail (0=passed, or 1=failed) results determined by testing the power relative to the segment frequencies:</p> <ol style="list-style-type: none"> 1. Reserved for future use, returns -999.0 2. Reserved for future use, returns -999.0 3. Negative offset frequency (A) or region (A) 4. Positive offset frequency (A) <p style="text-align: center;">. . .</p> <ol style="list-style-type: none"> 1. Negative offset frequency (E) or region (E) 2. Positive offset frequency (E) <p>When [:SENSe]:SEMAsk:SEGMENT is set to REGion, the positive offsets are not available and return -999.0.</p>

Measurement Type	n	Results Returned
	9	<p>Returns 12 scalar values of frequency (in Hz) that have peak power in each offset/region:</p> <ol style="list-style-type: none"> 1. Reserved for future use, returns -999.0 2. Reserved for future use, returns -999.0 3. Negative offset frequency (A) or region (A) 4. Positive offset frequency (A) <p style="text-align: center;">. . .</p> <ol style="list-style-type: none"> 1. Negative offset frequency (E) or region (E) 2. Positive offset frequency (E) <p>When [:SENSe]:SEMAsk:SEGMENT is set to REGION, the positive offsets are not available and return -999.0.</p>
	10	<p>Returns 12 scalar values (in dBm) of the absolute peak power of the segment frequencies:</p> <ol style="list-style-type: none"> 1. Reserved for future use, returns -999.0 2. Reserved for future use, returns -999.0 3. Negative offset frequency (A) or region (A) 4. Positive offset frequency (A) <p style="text-align: center;">. . .</p> <ol style="list-style-type: none"> 1. Negative offset frequency (E) or region (E) 2. Positive offset frequency (E) <p>When [:SENSe]:SEMAsk:SEGMENT is set to REGION, the positive offsets are not available and return -999.0.</p>
	11	<p>Returns 12 scalar values (in dBc) of the peak power relative to the carrier at the segment frequencies:</p> <ol style="list-style-type: none"> 1. Reserved for future use, returns -999.0 2. Reserved for future use, returns -999.0 3. Negative offset frequency (A) or region (A) 4. Positive offset frequency (A) <p style="text-align: center;">. . .</p> <ol style="list-style-type: none"> 1. Negative offset frequency (E) or region (E) 2. Positive offset frequency (E) <p>When [:SENSe]:SEMAsk:SEGMENT is set to REGION, the positive offsets are not available and return -999.0.</p>

Sensor Measurement

This checks the output of three sensors in the RF and IF circuitry. You must be in the Service mode to use these commands. Use INSTRument:SElect to set the mode.

The general functionality of CONFigure, FETCh, MEASure, and READ are described at the beginning of this section.

```
:CONFigure:SENSors
:INITiate:SENSors
:FETCh:SENSors[n]?
:READ:SENSors[n]?
:MEASure:SENSors[n]?
```

Front Panel

Access: With Service Mode selected, **Measure, Sensors**

Measurement Results Available

n	Results Returned
0	Not valid
n=1 (or not specified)	Returns the following scalar results: <ol style="list-style-type: none"> 1. IF signal amplitude is the ADC value for the detected 21.4 MHz IF signal at the input to the analog IF. 2. Calibration Oscillator Level is a floating point number (is not implemented, currently returns a zero). 3. RF temperature is a floating point number for the current temperature in the RF section (in degrees Celsius).

Spectrum (Frequency Domain) Measurement

For E4406A this measures the amplitude of your input signal with respect to the frequency. It provides spectrum analysis capability using FFT (fast Fourier transform) measurement techniques. You must select the appropriate mode using INSTRUMENT:SELEct, to use these commands.

For PSA this measures the amplitude of your input signal with respect to the frequency. It provides spectrum analysis capability using FFT (fast Fourier transform) measurement techniques. You must be in the Basic, cdmaOne, cdma2000, 1xEV-DO, W-CDMA, GSM (w/EDGE), NADC, or PDC mode to use these commands. Use INSTRUMENT:SELEct, to select the mode.

The general functionality of CONFigure, FETCh, MEASure, and READ are described at the beginning of this section. See the SENSE:SPECTrum commands for more measurement related commands.

```
:CONFigure:SPECTrum
:INITiate:SPECTrum
:FETCh:SPECTrum[n]?
:READ:SPECTrum[n]?
:MEASure:SPECTrum[n]?
```

Front Panel

Access: **Measure, Spectrum (Freq Domain)**

After the measurement is selected, press **Restore Meas Defaults** to restore factory defaults.

Measurement Results Available

n	Results Returned
0	Returns unprocessed I/Q trace data, as a series of trace point values, in volts. The I values are listed first in each pair, using the 0 through even-indexed values. The Q values are the odd-indexed values.

n	Results Returned
n=1 (or not specified)	<p>Returns the following scalar results:</p> <ol style="list-style-type: none"> 1. FFT peak is the FFT peak amplitude. 2. FFT frequency is the FFT frequency of the peak amplitude. 3. FFT points is the Number of points in the FFT spectrum. 4. First FFT frequency is the frequency of the first FFT point of the spectrum. 5. FFT spacing is the frequency spacing between the FFT points of the spectrum. 6. Time domain points is the number of points in the time domain trace used for the FFT. The number of points doubles if the data is complex instead of real. See the time domain scaler description below. 7. First time point is the time of the first time domain point, where time zero is the trigger event. 8. Time spacing is the time spacing between the time domain points. The time spacing value doubles if the data is complex instead of real. See the time domain scaler description below. 9. Time domain returns a 1 if time domain is complex (I/Q) and complex data will be returned. It returns a 0 if the data is real. (raw ADC samples) When this value is 1 rather than 0 (complex vs. real data), the time domain points and the time spacing scalers both increase by a factor of two. 10. Scan time is the total scan time of the time domain trace used for the FFT. The total scan time = (time spacing) X (time domain points – 1) 11. Current average count is the current number of data measurements that have already been combined, in the averaging calculation.
2, Service mode only	Returns the trace data of the log-magnitude versus time. (That is, the RF envelope.)
3	Returns the I and Q trace data. It is represented by I and Q pairs (in volts) versus time.
4	Returns spectrum trace data. That is, the trace of log-magnitude versus frequency. (The trace is computed using a FFT.)
5, Service mode only	Returns the averaged trace data of log-magnitude versus time. (That is, the RF envelope.)
6	Not used.
7	Returns the averaged spectrum trace data. That is, the trace of the averaged log-magnitude versus frequency.
8	Not used.
9, Service mode only	Returns a trace containing the shape of the FFT window.

n	Results Returned
10, Service mode only	Returns trace data of the phase of the FFT versus frequency.
11, cdma2000, 1xEV-DO, W-CDMA, Basic modes only	Returns linear spectrum trace data values in Volts RMS.
12, cdma2000, 1xEV-DO, W-CDMA, Basic modes only	Returns averaged linear spectrum trace data values in Volts RMS.

Timebase Frequency Measurement

The general functionality of CONFigure, FETCh, MEASure, and READ are described at the beginning of this section. See the SENSE:TBFRequency commands for more measurement related commands.

You must be in the Service mode to use these commands. Use INSTRument:SElect to set the mode.

```
:CONFigure:TBFRequency
:INITiate:TBFRequency
:FETCh:TBFRequency[n]?
:READ:TBFRequency[n]?
:MEASure:TBFRequency[n]?
```

Remarks: For auto adjustment of the internal frequency reference (10 MHz timebase), use the CALibration:FREQuency:REFerence:AADJust command after this measurement has been selected.

Front Panel

Access: **Measure, Timebase Freq**

After the measurement is selected, press **Restore Meas Defaults** to restore factory defaults.

Measurement Results Available

n	Results Returned
0	Not valid
n=1 (or not specified)	Returns 3 scalar results: <ol style="list-style-type: none"> 1. RF input average amplitude 2. Average frequency error 3. Adjustment in process (returns 1 if an adjustment is being performed, returns 0 if no adjustment is in process)
2	Frequency error stripchart trace data.
3	
4	

Terminal Code Domain Measurement

This measures the power levels of the spread channels in RF channel(s). You must be in the 1xEV-DO mode to use these commands. Use INSTRument:SELEct to set the mode.

This measurement is used only for mobile stations (access terminals). When measuring base stations (network access) use Code Domain Power Measurements (MEAS:CDPower) and set SENSE:RADio:DEVIce to BTS.

The general functionality of CONFigure, FETCh, MEASure, and READ are described at the beginning of this section. See the SENSE:CDPower commands for more measurement related commands.

```
:CONFigure:TCDPower
:INITiate:TCDPower
:FETCh:TCDPower[n]?
:READ:TCDPower[n]?
:MEASure:TCDPower[n]?
```

Front Panel

Access: **Measure, Code Domain**

After the measurement is selected, press **Restore Meas Defaults** to restore factory defaults.

Measurement Results Available

n	Results Returned
0	Returns unprocessed I/Q trace data, as a series of trace point values, in volts. The I values are listed first in each pair, using the 0 through even-indexed values. The Q values are the odd-indexed values.

n	Results Returned
n=1 (or not specified)	<p>Returns the following 19 scalar results:</p> <ol style="list-style-type: none"> 1. RMS symbol EVM is a floating point number (in percent) of the EVM over the entire measurement area. 2. Peak symbol EVM is a floating point number (in percent) of the peak EVM in the measurement area. 3. Symbol magnitude error is a floating point number (in percent) of the average magnitude error over the entire measurement area. 4. Symbol phase error is a floating point number (in degrees) of the average phase error over the entire measurement area. 5. Total power is a floating point number (in dBm) of the total RF power over the measurement interval. 6. Average power is a floating point number (in dBm) of the power in the entire slot, for the selected code, averaged over the measurement interval. 7. Total active power is a floating point number (in dB or dBm depending on the measurement type) of the sum of the active power. 8. Pilot power is a floating point number (in dB or dBm depending on the measurement type) of the average power of the Pilot code. 9. (Reserved) the value returned is always –999. 10. (Reserved) the value returned is always –999. 11. (Reserved) the value returned is always –999. 12. (Reserved) the value returned is always –999. 13. (Reserved) the value returned is always –999. 14. Number of active channels 15. I-channel average active power is a floating point number (in dB or dBm depending on the measurement type) of the average power of the active traffic channel. 16. I-channel maximum inactive power is a floating point number (in dB or dBm depending on the measurement type) of the maximum average power of all the inactive traffic channels. 17. Q-channel average active power is a floating point number (in dB or dBm depending on the measurement type) of the average power of the active traffic channel. 18. Q-channel maximum inactive power is a floating point number (in dB or dBm depending on the measurement type) of the maximum average power of the inactive traffic channels. 19. (Reserved) the value returned is always –999.

n	Results Returned
2	<p>Returns a series of floating point numbers (in dB or dBm depending on the measurement type) that represents all the code domain powers.</p> <p>Results are returned alternatively. Total is 32 I/Q pairs. If the active channel occupies more than the max spreading factor (16) the power is duplicated.</p> <p>1st number = 1st in-phase code power over the slot 2nd number = 1st quad-phase code power over the slot ... (2×N-1)th number = Nth in-phase code power over the slot (2×N)th number = Nth quad-phase code power over a slot</p> <p>N = the number of codes detected. The total number of codes varies because of the different symbol rates of each code.</p>
3	<p>Returns a series of floating point numbers (in dB or dBm depending on the measurement type) that represents all the code domain symbol rates.</p> <p>Results are returned alternatively. Total is 32 I/Q pairs. If the active channel occupies more than the max spreading factor (16) the power is duplicated.</p> <p>1st number = 1st in-phase code symbol rates over the slot 2nd number = 1st quad-phase codesymbol rates over the slot ... (2×N-1)th number = Nth in-phase code symbol rates over the slot (2×N)th number = Nth quad-phase code symbol rates over the slot</p> <p>N = the number of codes detected. The total number of codes varies because of the different symbol rates of each code.</p>
4	<p>Returns a series of floating point numbers that show either active or inactive status for each of the code powers returned in n=2 and 3. If a code is inactive, the value returned is 0.0, otherwise a value >0.0 is returned.</p> <p>I and Q results are returned alternatively. 1st number = 1st in-phase code active flag 2nd number = 1st Quad Phase code active flag ... (2×N-1)th number = Nth in-phase code active flag (2×N)th number = Nth Quad Phase code active flag</p> <p>N = the number of codes detected. The total number of codes varies because of the different symbol rates of each code. 2nd number = 1st quad-phase code symbol rate over the slot</p>
5	<p>Returns a series of floating point numbers (in percent) that represent each sample in the <i>EVM</i> trace. The first number is the symbol 0 decision point and there are X points per symbol. Therefore, the decision points are at 0, 1×X, 2×X, 3×X. . .</p> <p>(where X = the number of points per chip)</p>

n	Results Returned
6	<p>Returns a series of floating point numbers (in percent) that represent each sample in the <i>magnitude error</i> trace. The first number is the symbol 0 decision point and there are X points per symbol. Therefore, the decision points are at 0, 1×X, 2×X, 3×X. . .</p> <p>(where X = the number of points per chip)</p>
7	<p>Returns a series of floating point numbers (in degrees) that represent each sample in the <i>phase error</i> trace. The first number is the symbol 0 decision point and there are X points per symbol. Therefore, the decision points are at 0, 1×X, 2×X, 3×X. . .</p> <p>(where X = the number of points per chip)</p>
8	<p>Returns series of floating point numbers that alternately represent I and Q pairs of the <i>corrected measured</i> trace. The magnitude of each I and Q pair is normalized to 1.0. The first number is the in-phase (I) sample of symbol 0 decision point and the second is the quadrature-phase (Q) sample of symbol 0 decision point. As in the EVM, there are X points per symbol, so that:</p> <p>1st number is I of the symbol 0 decision point 2nd number is Q of the symbol 0 decision point . . . (2×X)+1 number is I of the symbol 1 decision point (2×X)+2 number is Q of the symbol 1 decision point . . . (2×X)×N+1th number is I of the symbol N decision point (2×X)×N+2th number is Q of the symbol N decision point</p> <p>where X = the number of points per symbol, and N = the number of symbols</p>
9	<p>Returns series of floating point numbers (in dBm) that represent the trace data of the symbol power vs. time.</p>
10	<p>Returns series of floating point numbers (in dBm) that represent the trace data of the chip power vs. time.</p>
11	<p>Returns a series of floating point numbers (0.0 or 1.0) of the symbol values (demodulated bits) for the selected spread code. The results are returned as alternating values of I,Q,I,Q . . . for the entire measurement interval.</p>
12 W-CDMA mode	<p>Returns series of floating point numbers (0.0 or 1.0) of symbol values for the selected code with the period selected by Meas Interval, and Meas Offset and tDPCH, when :CALCulate:CDPower:DBITs[:FORMat] is set to BINary. Returns series of floating point numbers (0.0, 1.0 or -1.0) of symbol values for the selected code with the period selected by Meas Interval, and Meas Offset and tDPCH, when :CALCulate:CDPower:DBITs[:FORMat] is set to TRIState. “-1.0” represents DTX (Discontinuous Transmission) bit.</p>

Terminal Modulation Accuracy (Rho) Measurement

This measures the modulation accuracy of the 1xEV-DO terminal transmitter (mobile unit) by checking the magnitude and phase error and the EVM (error vector magnitude). You must be in the 1xEV-DO mode to use these commands. Use INSTRument:SELEct to set the mode.

For network access equipment, use MEAS:RHO to measure modulation accuracy, after selecting base transmitter stations using SENSE:RADio:DEVIce BTS.

The general functionality of CONFIgure, FETCh, MEASure, and READ are described at the beginning of this section. See the SENSE:RHO commands for more measurement related commands.

```
:CONFIgure:TRHO
:INITiate:TRHO
:FETCh:TRHO[n]?
:READ:TRHO[n]?
:MEASure:TRHO[n]?
```

Front Panel

Access: **Measure, Mod Accuracy**

After the measurement is selected, press **Restore Meas Defaults** to restore factory defaults.

Measurement Results Available

n	Results Returned
0	Returns unprocessed I/Q trace data, as a series of trace point values. The I values are listed first in each pair, using the 0 through even-indexed values. The Q values are the odd-indexed values.

n	Results Returned
n=1 (or not specified)	<p>Returns following 16 comma-separated scalar results, in the following order:</p> <ol style="list-style-type: none"> 1. RMS EVM – a floating point number (in percent) of EVM over the entire measurement area. 2. Peak EVM error – a floating point number (in percent) of peak EVM in the measurement area. 3. Magnitude error – a floating point number (in percent) of average magnitude error over the entire measurement area. 4. Phase error – a floating point number (in degree) of average phase error over the entire measurement area. 5. I/Q Origin Offset – a floating point number (in dB) of the I and Q error (magnitude squared) offset from the origin. 6. Frequency error – a floating point number (in Hz) of the frequency error in the measured signal. 7. Rho – a floating point number of Rho. 8. Peak code domain error – a floating point number (in percent) of peak code domain error in the measurement area. 9. Peak code domain error channel number– returns the channel number which contained the peak code domain error in the measurement area. 10. Number of active channels. <p>Following result is available for all measurement modes:</p> <ol style="list-style-type: none"> 11. Pilot Offset – a floating point number (in micro seconds) of pilot offset from the trigger point. 12. Max Inactive Channel Code Domain Power – a floating point number (in dB) of the Max Inactive Channel Code Domain Power 13. RRI Relative Power – a floating point number (in dB) of the RRI power relative to Pilot 14. DRC Channel Relative Power – a floating point number (in dB) of the DRC Channel Power relative to Pilot 15. ACK Channel Relative Power – a floating point number (in dB) of the ACK Channel Power relative to Pilot 16. Data Channel Relative Power – a floating point number (in dB) of the Data Channel Power relative to Pilot
2	<p>EVM trace – returns series of floating point numbers (in percent) that represent each sample in the EVM trace. The first number is the symbol 0 decision point. There are X points per symbol ($X = \text{points/chip}$). Therefore, the decision points are at $0, 1 \times X, 2 \times X, 3 \times X \dots$</p>

n	Results Returned
3	<p>Magnitude error trace – returns series of floating point numbers (in percent) that represent each sample in the magnitude error trace. The first number is the symbol 0 decision point. There are X points per symbol ($X = \text{points/chip}$). Therefore, the decision points are at $0, 1 \times X, 2 \times X, 3 \times X$. . .</p>
4	<p>Phase error trace – returns series of floating point numbers (in degrees) that represent each sample in the phase error trace. There are X points per symbol ($X = \text{points/ chip}$). Therefore, the decision points are at $0, 1 \times X, 2 \times X, 3 \times X$. . .</p>
5	<p>Corrected measured trace – returns series of floating point numbers that alternately represent I and Q pairs of the corrected measured trace. The magnitude of each I and Q pair are normalized to 1.0. The first number is the in-phase (I) sample of symbol 0 decision point and the second is the quadrature-phase (Q) sample of symbol 0 decision point. There are X points per symbol ($X = \text{points/chip}$), so the series of numbers is:</p> <p style="padding-left: 40px;">1st number = I of the symbol 0 decision point 2nd number = Q of the symbol 0 decision point . . . $(2 \times X) + 1$, number = I of the symbol 1 decision point $(2 \times X) + 2$, number = Q of the symbol 1 decision point . . . $(2 \times X) \times N\text{th} + 1$ number = I of the symbol N decision point $(2 \times X) \times N\text{th} + 2$ number = Q of the symbol N decision point</p>
6	<p>Returns 11 comma-separated scalar values of the pass/fail (0.0=passed, or 1.0=failed) results determined by testing the EVM, Peak EVM:</p> <ol style="list-style-type: none"> 1. Test result of EVM 2. Test result of Peak EVM 3. Test result of Rho 4. Test result of Peak Code Domain Error 5. Test result of Frequency Error 6. Test result of Pilot Offset 7. Test result of Max Inactive channel code domain power 8. Test result of RRI Relative Power 9. Test result of ACK Channel Relative Power 10. Test result of DRC Channel Relative Power 11. Test result of Data Channel Relative Power

Transmit Band Spurs Measurement

This measures the spurious emissions in the transmit band relative to the channel power in the selected channel. You must be in the EDGE, GSM mode to use these commands. Use INSTRument:SElect to set the mode.

The general functionality of CONFigure, FETCh, MEASure, and READ are described at the beginning of this section. See the SENSE:TSPur commands for more measurement related commands.

:CONFigure:TSPur

:INITiate:TSPur

:FETCh:TSPur[n]?

:READ:TSPur[n]?

:MEASure:TSPur[n]?

History: Version A.03.00 or later

Front Panel

Access: Measure, Tx Band Spurs

After the measurement is selected, press **Restore Meas Defaults** to restore factory defaults.

Measurement Results Available

n	Results Returned
0	Returns unprocessed I/Q trace data, as a series of trace point values, in volts. The I values are listed first in each pair, using the 0 through even-indexed values. The Q values are the odd-indexed values.
n=1 (or not specified)	Returns 3 scalar results: 1. The worst spur's frequency difference from channel center frequency (in MHz) 2. The worst spur's amplitude difference from the limit (in dB) 3. The worst spur's amplitude difference from the mean transmit power (in dB)
2	Returns the current trace data (401 point real number comma separated list).

Transmit Power Measurement

This measures the power in the channel. It compares the average power of the RF signal burst to a specified threshold value. You must be in the EDGE, GSM mode to use these commands. Use INSTRument:SElect to set the mode.

The general functionality of CONFigure, FETCh, MEASure, and READ are described at the beginning of this section. See the SENSE:TXPower commands for more measurement related commands.

- :CONFigure:TXPower
- :INITiate:TXPower
- :FETCh:TXPower[n]?
- :READ:TXPower[n]?
- :MEASure:TXPower[n]?

Front Panel

Access: **Measure, Transmit Power**

After the measurement is selected, press **Restore Meas Defaults** to restore factory defaults.

Measurement Results Available

n	Results Returned
0	Returns unprocessed I/Q trace data, as a series of trace point values, in volts. The I values are listed first in each pair, using the 0 through even-indexed values. The Q values are the odd-indexed values.

n	Results Returned
n=1 (or not specified)	<p>Returns the following scalar results:</p> <ol style="list-style-type: none"> 1. Sample time is a floating point number representing the time between samples when using the trace queries (n=0,2,etc). 2. Power is the mean power (in dBm) of the power above the threshold value. If averaging is on, the power is for the latest acquisition. 3. Power averaged is the threshold power (in dBm) for N averages, if averaging is on. An average consists of N acquisitions of data which represents the current trace. If averaging is off, the value of power averaged is the same as the power value. 4. Number of samples is the number of data points in the captured signal. This number is useful when performing a query on the signal (i.e. when n=0,2,etc.). 5. Threshold value is the threshold (in dBm) above which the power is calculated. 6. Threshold points is the number of points that were above the threshold and were used for the power calculation. 7. Maximum value is the maximum of the most recently acquired data (in dBm). 8. Minimum value is the minimum of the most recently acquired data (in dBm).
2	<p>Returns trace point values of the entire captured trace data. These data points are floating point numbers representing the power of the signal (in dBm). There are N data points, where N is the number of samples. The period between the samples is defined by the sample time.</p>

Waveform (Time Domain) Measurement

For E4406A this measures the amplitude of your input signal with respect to the frequency. It provides spectrum analysis capability using FFT (fast Fourier transform) measurement techniques. You must select the appropriate mode using INSTRUMENT:SElect, to use these commands.

For PSA this measures the amplitude of your input signal with respect to the frequency. It provides spectrum analysis capability using FFT (fast Fourier transform) measurement techniques. You must be in the Basic, cdmaOne, cdma2000, 1xEV-DO, W-CDMA, GSM (w/EDGE), NADC, or PDC mode to use these commands. Use INSTRUMENT:SElect, to select the mode.

The general functionality of CONFigure, FETCh, MEASure, and READ are described at the beginning of this section. See the SENSE:WAVEform commands for more measurement related commands.

```
:CONFigure:WAVEform
:INITiate:WAVEform
:FETCh:WAVEform[n]?
:READ:WAVEform[n]?
:MEASure:WAVEform[n]?
```

Front Panel

Access: **Measure, Waveform (Time Domain)**

After the measurement is selected, press **Restore Meas Defaults** to restore factory defaults.

Measurement Results Available

n	Results Returned
0 (see also 5)	Returns unprocessed I/Q trace data, as a series of trace point values, in volts. The I values are listed first in each pair, using the 0 through even-indexed values. The Q values are the odd-indexed values.

n	Results Returned
n=1 (or not specified)	<p>Returns the following scalar results:</p> <ol style="list-style-type: none"> 1. Sample time is a floating point number representing the time between samples when using the trace queries (n=0,2,etc). 2. Mean power is the mean power (in dBm). This is either the power across the entire trace, or the power between markers if the markers are enabled. If averaging is on, the power is for the latest acquisition. 3. Mean power averaged is the power (in dBm) for N averages, if averaging is on. This is either the power across the entire trace, or the power between markers if the markers are enabled. If averaging is on, the power is for the latest acquisition. If averaging is off, the value of the mean power averaged is the same as the value of the mean power. 4. Number of samples is the number of data points in the captured signal. This number is useful when performing a query on the signal (i.e. when n=0,2,etc.). 5. Peak-to-mean ratio has units of dB. This is the ratio of the maximum signal level to the mean power. Valid values are only obtained with averaging turned off. If averaging is on, the peak-to-mean ratio is calculated using the highest peak value, rather than the displayed average peak value. 6. Maximum value is the maximum of the most recently acquired data (in dBm). 7. Minimum value is the minimum of the most recently acquired data (in dBm).
2	<p>Returns trace point values of the entire captured signal envelope trace data. These data points are floating point numbers representing the power of the signal (in dBm). There are N data points, where N is the number of samples. The period between the samples is defined by the sample time.</p>
3, Option B7C with cdma2000, W-CDMA, Basic modes only (E4406A only)	<p>Returns magnitude values of the time data in Volts peak.</p>
4, Option B7C with cdma2000, W-CDMA, Basic modes only (E4406A only)	<p>Returns values of phase data in degrees.</p>

MEMory Subsystem

The purpose of the MEMory subsystem is to manage instrument memory. This specifically excludes memory used for mass storage which is defined in the MMEMory Subsystem.

Install an Application

```
:MEMory:INSTall:APPLication <'filename'>
```

Installs the specified application from an external drive to the instrument. Each application allows you to make a specific set of measurements easily and accurately.

Completing the installation requires a 12-character license key that you received with your application. The license key number is unique to the option and instrument serial number. If it cannot be located, contact your local Hewlett-Packard Sales and Service office to re-obtain the information. (Have the instrument model number, host ID, and serial number available when ordering a new option.)

Front Panel

Access: **System, Uninstall**

Un-install an Application

```
:MEMory:UNINStall:APPLication <'filename'>
```

Uninstalls the specified application from the instrument user memory. Use the MEM:INST:APPL command to restore it to memory.

Front Panel

Access: **System, Uninstall**

MEMory Subsystem

MMEMory Subsystem

The purpose of the MMEMory subsystem is to provide access to mass storage devices such as internal or external disk drives. If mass storage is not specified in the filename, the default mass storage specified in the MSIS command will be used.

The MMEMory command syntax term <file_name> is a specifier having the form: drive:name.ext, where the following rules apply:

- “drive” is “A:” or “C:”
- “name” is a DOS file name of up to eight characters, letters (A-Z, a-z) and numbers (0-9) only (lower case letters are read as uppercase)
- “ext” is an optional file extension using the same rules as “name,” but consists of up to three characters total. (The default file extension will be added if it is not specified.)

Memory Available or In-Use

:MMEMory:FREE?

Queries the memory for optional application modes, like option BAH (GSM mode) or option BAE (NADC/PDC mode). The query returns two values, the memory currently in use and the free memory. The sum of the two values is the total instrument memory.

History: Revision A.03.00 or later

Front Panel

Access: **System, File System**

Select a Memory Device

:MMEMory:MSIS A|[C]

:MMEMory:MSIS?

Selects a default mass storage device which is used by all MMEMory commands.

The query returns the default mass storage device.

A is the 3.5 inch floppy disk

C is the internal memory

Example: MMEM:MSIS C

History: Added in version A.04.00 and later

Front Panel

Access: **Print Setup, Print To File, File Location**

Store a Screen Image in a Graphic File

:MMEMory:STORe:SCReen[:IMMediate] <filename>

The **:MMEMory:STORe:SCReen[:IMMediate]** command will write the screen image to a file regardless of what the front panel **Print Setup, Print To** key function is set to. Screen files are always saved in color with an orientation of portrait.

The <filename> variable is composed of:
[<device>:]<name>[.<extension>] where:

<filename> is a string that must be enclosed in single (') or double (") quotes.

<device> must be A or C. Upper or lower case is acceptable. If device is not specified the default is set by **MMEM:MSIS**.

<name> must be 1 to 8 characters in length and consist only of the characters a..z, A..Z and 0..9 (no underscore). If a name is not specified the default is screen1.

<.extension> must be .gif | .bmp | .wmf. (Note the lower case.) If a file type extension is not specified the default is set by **MMEM:STORE:SCREEN:FILE:TYPE**

Example: **MMEM:STOR:SCR "C:myscreen.gif"**

Remarks: When writing to A, <name> can be any valid DOS-compatible name.

When writing to C, <name> must be screen1 . . . screen6. (Note the lower case.)

If you write a file to C any existing screen file with the same name will be replaced, regardless of the extensions. For example, file screen3.gif will replace file screen3.bmp

History: **VSA - Added in version A.04.00 and later**

Front Panel

Access: **Print Setup, Print To File**
Print

Screen File Type

:MMEMory:STORe:SCREen:FILE[:TYPE] GIF|BMP|WMF

Sets the default file type for the :MMEMory:STORe:SCREen command.

Factory Preset: GIF. The file type setting is persistent. It stays at the last user-selected setting even through a power cycle.

Default: GIF

History: Added in version A.04.00 and later

Front Panel

Access: **Print Setup, Print To File, File Type**

Screen Image Background

:MMEMory:STORe:SCREen:IMAGe NORMal|INVert

:MMEMory:STORe:SCREen:IMAGe?

Selects the background color of trace data windows when writing to a file.

NORMal background is black.

INVert background is white.

Factory Preset: The image setting is persistent. It stays at the last user-selected setting even through a power cycle.

Default: Invert

History: Added in version A.04.00 and later

Front Panel

Access: **Print Setup, Print To File, Image**

READ Subsystem

The READ? commands are used with several other commands and are documented in the section on the [“MEASure Group of Commands” on page 193](#).

Initiate and Read Measurement Data

:READ:<measurement>[n]?

A READ? query must specify the desired measurement. It will cause a measurement to occur without changing any of the current settings and will return any valid results. The code number n selects the kind of results that will be returned. The available measurements and data results are described in the [“MEASure Group of Commands” on page 193](#).

READ Subsystem

SENSe Subsystem

These commands are used to set the instrument state parameters so that you can measure a particular input signal. Some SENSe commands are only for use with specific measurements found under the MEASURE key menu or the “MEASure Group of Commands” on page 193. The measurement must be active before you can use these commands.

The SCPI default for the format of any data output is ASCII. The format can be changed to binary with FORMat:DATA which transports faster over the bus.

Adjacent Channel Power Measurement

Commands for querying the adjacent channel power measurement results and for setting to the default values are found in the “MEASure Group of Commands” on page 193. The equivalent front panel keys for the parameters described in the following commands, are found under the **Meas Setup** key, after the **ACP** or **ACPR** measurement has been selected from the **MEASURE** key menu.

Adjacent Channel Power—Average Count

[:SENSe] :ACP :AVERAge :COUNT <integer>

[:SENSe] :ACP :AVERAge :COUNT ?

Set the number of data acquisitions that will be platform averaged. After the specified number of average counts, the average mode (termination control) setting determines the average action.

Factory Preset: 10 for cdma2000, W-CDMA
20 for Basic, cdmaOne, iDEN (E4406A)

Range: 1 to 10,000

Remarks: Use INSTRument:SElect to set the mode.

Front Panel

Access: **Meas Setup**

Adjacent Channel Power—Averaging State

[:SENSe] :ACP :AVERAge [:STATE] OFF | ON | 0 | 1

[:SENSe] :ACP :AVERAge [:STATE] ?

Turn the averaging function On or Off.

Factory Preset: On
Off for iDEN mode (E4406A)

Remarks: Use INSTRument:SElect to set the mode.

SENSe Subsystem

Front Panel

Access: **Meas Setup**

Adjacent Channel Power—Averaging Termination Control

```
[ :SENSe ] :ACP:AVERAge:TCONtrol EXPonential | REPeat
```

```
[ :SENSe ] :ACP:AVERAge:TCONtrol?
```

Select the type of termination control used for averaging. This determines the averaging action after the specified number of data acquisitions (average count) is reached.

EXPonential – Each successive data acquisition after the average count is reached, is exponentially weighted and combined with the existing average.

REPeat – After reaching the average count, the averaging is reset and a new average is started.

Factory Preset: REPeat for E4406A Basic, cdmaOne, cdma2000, W-CDMA

EXPonential for E4406A iDEN

EXPonential for NADC, PDC

Remarks: Use INSTRument:SElect to set the mode.

Adjacent Channel Power—Type of Carrier Averaging

```
[ :SENSe ] :ACP:AVERAge:TYPE MAXimum | RMS
```

```
[ :SENSe ] :ACP:AVERAge:TYPE?
```

Selects the type of averaging to be used for the measurement of the carrier.

Factory Preset: RMS

Remarks: You must be in Basic (E4406A), or cdmaOne mode to use this command. Use INSTRument:SElect to set the mode.

History: E4406A:
Revision A.03.00 or later, in cdmaOne revision A.04.00

Front Panel

Access: **Meas Setup, Avg Mode**

Adjacent Channel Power—Carrier Channel BW

Basic, iDEN mode (E4406A)

```
[ :SENSe ] :ACP:BANDwidth | BWIDth:INTEgration <freq>
```

```
[ :SENSe ] :ACP:BANDwidth | BWIDth:INTEgration?
```

cdma2000, W-CDMA mode

[:SENSE] :ACP :BANDwidth [n] | BWIDth [n] :INTEgration <freq>

[:SENSE] :ACP :BANDwidth [n] | BWIDth [n] :INTEgration?

cdmaOne mode

[:SENSE] :ACP :BANDwidth [n] | BWIDth [n] :INTEgration [m] <freq>

[:SENSE] :ACP :BANDwidth [n] | BWIDth [n] :INTEgration [m]?

Set the Integration bandwidth that will be used for the main (carrier) channel.

BANDwidth [n] | BWIDth [n]: m=1 is base station and 2 is mobiles. The default is base station (1).

INTEgration [n]: m=1 is cellular bands and 2 is pcs bands. The default is cellular.

Factory Preset:

Mode	Format (Modulation Standard)		
Basic (E4406A)	1.23 MHz		
cdmaOne	1.23 MHz		
iDEN (E4406A)	18 kHz		
cdma2000	1.23 MHz		
W-CDMA	3.84 MHz		

Range: 300 Hz to 20 MHz for Basic (E4406A), cdmaOne, cdma2000, or W-CDMA mode

1 kHz to 5 MHz for iDEN (E4406A)

Default Unit: Hz

Remarks: With measurement type set at (TPR) total power reference, 1.40 MHz is sometimes used. Using 1.23 MHz will give a power that is very nearly identical to the 1.40 MHz value, and using 1.23 MHz will also yield the correct power spectral density with measurement type set at (PSD) reference. However, a setting of 1.40 MHz will not give the correct results with measurement type set at PSD reference.

For E4406A you must be in Basic, cdmaOne, cdma2000, W-CDMA, or iDEN mode to use this command. Use INSTRUMENT:SElect to set the mode.

Adjacent Channel Power—Dynamic Range

[:SENSE] :ACP :DYNamic [n] :RANGE [m] HIGH | NORMAl | MODified

SENSE Subsystem

[:SENSE] :ACP:DYNAMIC[n] :RANGE[m] ?

Select a dynamic range optimization.

High - chooses settings that provide better dynamic range (better signal to noise ratio) at the expense of longer measurement times. This is a better choice for CDMA signals with multiple carriers turned on at the same time.

Normal - lets the measurement automatically choose settings that trade off dynamic range for faster measurement speed. This is a good choice for making CDMA measurements on a signal with only one carrier turned on at a time.

Modified- is not a customer settable option. This choice is automatically selected depending on your selection of other related settings in the advanced measurement setup, like the number of FFT segments.

Dynamic [n]	n=1 is BTS (base station) and 2 is MS (mobile station). The default is base station (1).
Range [m]	m=1 is cellular bands (IS-95A) and 2 is pcs bands (J-STD-008) for cdmaOne. The default is cellular (1).
Factory Preset:	NORMAL
Remarks:	You must be in the cdmaOne mode to use this command. Use INSTRUMENT:SELEct to set the mode.
History:	E4406A: Added A.04.00. Revised for A.05.00.

Adjacent Channel Power—Fast Mode ADC Range

[:SENSE] :ACP:FAST:OFFSet:ADC:RANGE
AUTO | APEak | APLOCK | M6 | P0 | P6 | P12 | P18 | P24 (for E4406A)

[:SENSE] :ACP:FAST:OFFSet:ADC:RANGE
AUTO | APEak | APLOCK | NONE | P0 | P6 | P12 | P18 (for PSA)

[:SENSE] :ACP:FAST:OFFSet:ADC:RANGE?

Select the range for the gain-ranging that is done in front of the ADC when the [:SENSE] :ACP:SWEep:TYPE is set to Fast. This is an advanced control that normally does not need to be changed. If you are measuring a CW signal, see the description below.

- Auto - sets the ADC range automatically. For most FFT measurements, the auto feature should not be selected. An exception is when measuring a signal which is “bursty,” in which case the auto feature can maximize the time domain dynamic range, if FFT results are less important to you than time domain results.
- Auto Peak (APEak) - sets the ADC range automatically to the peak signal level. The auto peak feature is a compromise that works well for both CW and burst signals.

- Auto Peak Lock (APLock) - holds the ADC range automatically at the peak signal level. The auto peak lock feature is more stable than the auto peak feature for CW signals, but should not be used for “bursty” signals.
- NONE - (PSA) turns off any auto-ranging without changing the current setting.
- M6 - (E4406A) sets an ADC range that subtracts 6 dB of fixed gain across the range manually. Manual ranging is best for CW signals.
- P0, P6, P12, or P18 - (PSA) selects ADC ranges that add 0, 6, 12, or 18 dB of fixed gain across the range manually. Manual ranging is best for CW signals.
- P0, P6, P12, P18, or P24 - (E4406A) selects ADC ranges that add 0, 6, 12, 18, or 24 dB of fixed gain across the range manually. Manual ranging is best for CW signals.

Factory Preset: Auto Peak (APEak)

Remarks: You must be in the W-CDMA mode to use this command. Use INSTRument:SElect to set the mode.

Adjacent Channel Power—Fast Mode Relative Attenuation

[:SENSe]:ACP:FAST:OFFSet:RATTenuation <rel power>

[:SENSe]:ACP:FAST:OFFSet:RATTenuation?

Sets a relative amount of attenuation for the measurements at the offset channels when the [:SENSe]:ACP:SWEep:TYPE is set to Fast. This attenuation is always specified relative to the attenuation that is required to measure the carrier channel. Since the offset channel power is lower than the carrier channel power, less attenuation is required to measure the offset channels and wider dynamic range for the measurement is available.

Factory Preset: 0

Range: -40.00 to 0.00 dB

Remarks: You must be in the W-CDMA mode to use this command. Use INSTRument:SElect to set the mode.

Adjacent Channel Power—Root Raised Cosine Filter Alpha

[:SENSe]:ACP:FILTer[:RRC]:ALPHA <numeric>

[:SENSe]:ACP:FILTer[:RRC]:ALPHA?

Set the alpha value of the Root Raised Cosine (RRC) filter.

Factory Preset: 0.22

Range: 0.01 to 0.5

Remarks: You must be in the W-CDMA mode to use this command. Use

SENSE Subsystem

INSTRument:SElect to set the mode.

Adjacent Channel Power—Root Raised Cosine Filter Control

[:SENSE] :ACP:FILTer [:RRC] [:STATe] OFF | ON | 0 | 1

[:SENSE] :ACP:FILTer [:RRC] [:STATe] ?

Turn the Root Raised Cosine (RRC) filter on or off.

Factory Preset: On

Remarks: You must be in the W-CDMA mode to use this command. Use INSTRument:SElect to set the mode.

Adjacent Channel Power—Reference Channel FFT Segments

[:SENSE] :ACP:FFTSegment <integer>

[:SENSE] :ACP:FFTSegment ?

Selects the number of FFT segments used in making the measurement of the reference channel (carrier). In automatic mode the measurement optimizes the number of FFT segments required for the shortest measurement time. The minimum number of segments required to make a measurement is set by your desired measurement bandwidth. Selecting more than the minimum number of segments will give you more dynamic range for making the measurement, but the measurement will take longer to execute.

To use this command you must first set SENSE:ACP:FFTS:AUTO to off.

Factory Preset: 1

Range: 1 to 12

Remarks: You must be in Basic (E4406A), or cdmaOne mode to use this command. Use INSTRument:SElect to set the mode.

History: E4406A:
Revision A.03.00 or later, in cdmaOne revision A.04.00

Adjacent Channel Power—Reference Channel FFT Segments State

[:SENSE] :ACP:FFTSegment:AUTO OFF | ON | 0 | 1

[:SENSE] :ACP:FFTSegment:AUTO ?

The automatic mode selects the optimum number of FFT segments to measure the reference channel (carrier), while making the fastest possible measurement.

Factory Preset: ON

Remarks: You must be in Basic (E4406A), or cdmaOne mode to use this

command. Use INSTRument:SElect to set the mode.

History: E4406A:
Revision A.03.00 or later, in cdmaOne revision A.04.00

Adjacent Channel Power—Frequency Span Query

[[:SENSe]:ACP:FREQuency:SPAN?

Returns the span of the spectrum view.

Remarks: You must be in Basic (E4406A), or cdmaOne mode to use this command. Use INSTRument:SElect to set the mode.

History: E4406A:
Revision A.05.00 or later

Adjacent Channel Power—Offset Frequency Absolute Limit

**[[:SENSe]:ACP:LIST:ALIMit
<abs_powr>,<abs_powr>,<abs_powr>,<abs_powr>,<abs_powr>**

[[:SENSe]:ACP:LIST:ALIMit?

Set the absolute limit on offset frequencies relative to the carrier. You can turn off (not use) specific offsets with the [[:SENSe]:ACP:LIST:STATe command.

Factory Preset:

Mode	Offset A	Offset B	Offset C	Offset D	Offset E
NADC	0 dBm	0 dBm	-13 dBm	0 dBm	0 dBm
PDC	0 dBm	0 dBm	0 dBm	0 dBm	0 dBm

Range: -200 to 50 dBm

Remarks: You must be in the NADC, cdmaOne, or PDC mode to use this command. Use INSTRument:SElect to set the mode.

Adjacent Channel Power—Offset Frequency

**[[:SENSe]:ACP:LIST[:FREQuency]
<f_offset>,<f_offset>,<f_offset>,<f_offset>,<f_offset>**

[[:SENSe]:ACP:LIST[:FREQuency]?

Define the offset frequencies. You can turn off (not use) specific offsets with the [[:SENSe]:ACP:LIST:STATe command.

SENSe Subsystem

Factory Preset:

Mode	Offset A	Offset B	Offset C	Offset D	Offset E
NADC	30 kHz	60 kHz	90 kHz	120 kHz	0 Hz
PDC	50 kHz	100 kHz	0 kHz	0 kHz	0 kHz

Range: 10 Hz to 45 MHz

0 to 200 kHz

Default Unit: Hz

Remarks: You must be in the NADC, cdmaOne, or PDC mode to use this command. Use INSTRument:SElect to set the mode.

Adjacent Channel Power—Offset Frequency Power Mode

```
[ :SENSe ] :ACP:LIST:POWer  
INTeg | PEAK , INTeg | PEAK , INTeg | PEAK , INTeg | PEAK , INTeg | PEAK
```

```
[ :SENSe ] :ACP:LIST:POWer?
```

Define the power measurement mode for each of the offset frequencies. You can turn off (not use) specific offsets with the SENS:ACP:LIST:STATE command.

Factory Preset: INTeg, INTeg, INTeg, INTeg, INTeg

Remarks: You must be in the NADC mode to use this command. Use INSTRument:SElect to set the mode.

Adjacent Channel Power—Offset Frequency Relative Limit

```
[ :SENSe ] :ACP:LIST:RLIMit  
<rel_powr> , <rel_powr> , <rel_powr> , <rel_powr> , <rel_powr>
```

```
[ :SENSe ] :ACP:LIST:RLIMit?
```

Set the relative limit on offset frequencies. You can turn off (not use) specific offsets with the SENS:ACP:LIST:STATE command.

Factory Preset: -45 dB

Mode	Offset A	Offset B	Offset C	Offset D	Offset E
NADC	-26 dB	-45 dB	-45 dB	0 dB	0 dB
PDC	-45 dB	-60 dB	0 dB	0 dB	0 dB

Range: -200 to 50 dB

Remarks: You must be in the NADC, cdmaOne, or PDC mode to use this

command. Use INSTRument:SElect to set the mode.

Adjacent Channel Power—Offset Frequency Control

```
[ :SENSe]:ACP:LIST:STATe OFF|ON|0|1, OFF|ON|0|1, OFF|ON|0|1,
OFF|ON|0|1, OFF|ON|0|1
```

```
[ :SENSe]:ACP:LIST:STATe?
```

Turn measurement on or off for the custom offset frequencies.

Factory Preset:

Mode	Offset A	Offset B	Offset C	Offset D	Offset E
NADC	ON	ON	ON	OFF	OFF
PDC	ON	ON	OFF	OFF	OFF

Remarks: You must be in the NADC, cdmaOne, or PDC mode to use this command. Use INSTRument:SElect to set the mode.

Adjacent Channel Power—Offset Frequency Test Mode

```
[ :SENSe]:ACP:LIST:TEST ABSolute|AND|RELative|OR,
ABSolute|AND|RELative|OR, ABSolute|AND|RELative|OR,
ABSolute|AND|RELative|OR, ABSolute|AND|RELative|OR
```

```
[ :SENSe]:ACP:LIST:TEST?
```

Define the type of testing to be done for the five custom offset frequencies. You can turn off (not use) specific offsets with the SENS:ACP:LIST:STATe command.

Factory Preset: RELative, RELative, OR, AND, AND for NADC, PDC mode

Remarks: You must be in the NADC, cdmaOne, or PDC mode to use this command. Use INSTRument:SElect to set the mode.

Adjacent Channel Power—Absolute Amplitude Limits

iDEN mode (E4406A)

```
[ :SENSe]:ACP:OFFSet:ABSolute <power>
```

```
[ :SENSe]:ACP:OFFSet:ABSolute?
```

Basic (E4406A), cdmaOne mode

```
[ :SENSe]:ACP:OFFSet:LIST:ABSolute
<power>, <power>, <power>, <power>, <power>
```

```
[ :SENSe]:ACP:OFFSet:LIST:ABSolute?
```

SENSe Subsystem

cdma2000, W-CDMA mode

```
[ :SENSe ] :ACP:OFFSet [ n ] :LIST:ABSolute
<power> , <power> , <power> , <power> , <power>
```

```
[ :SENSe ] :ACP:OFFSet [ n ] :LIST:ABSolute?
```

Sets the absolute amplitude levels to test against for each of the custom offsets. The list must contain five (5) entries. If there is more than one offset, the offset closest to the carrier channel is the first one in the list.

[:SENSe] :ACP:OFFSet [n] :LIST [m] :TEST selects the type of testing to be done at each offset.

You can turn off (not use) specific offsets with the [:SENSe] :ACP:OFFSet [n] :LIST:STATe command.

The query returns the five (5) sets of the real numbers that are the current absolute amplitude test limits.

Offset [n] n=1 is base station and 2 is mobiles. The default is base station (1).

List [n] m=1 is cellular bands and 2 is pcs bands. The default is cellular.

Factory Preset:

Mode	Variant	Offset A	Offset B	Offset C	Offset D	Offset E
Basic (E4406A)		0 dBm	0 dBm	0 dBm	0 dBm	0 dBm
cdmaOne	BS cellular	0 dBm	0 dBm	0 dBm	0 dBm	0 dBm
	BS pcs	0 dBm	-13 dBm	-13 dBm	0 dBm	0 dBm
	MS cellular	0 dBm	0 dBm	0 dBm	0 dBm	0 dBm
	MS pcs	0 dBm	-13 dBm	-13 dBm	0 dBm	0 dBm
cdma2000		50 dBm	50 dBm	50 dBm	50 dBm	50 dBm
W-CDMA		50 dBm	50 dBm	50 dBm	50 dBm	50 dBm
iDEN (E4406A)		0 dBm	n/a	n/a	n/a	n/a

Range: -200.0 dBm to 50.0 dBm

Default Unit: dBm

Remarks: For E4406A you must be in Basic, cdmaOne, cdma2000, W-CDMA, or iDEN mode to use this command. Use INSTRument:SElect to set the mode.

Adjacent Channel Power—Type of Offset Averaging

```
[ :SENSe ] :ACP:OFFSet :LIST:AVERAge :TYPE MAXimum | RMS
```

[:SENSe] :ACP:OFFSet:LIST:AVERAge:TYPE?

Selects the type of averaging to be used for the measurement at each offset. You can turn off (not use) specific offsets with the SENS:ACP:OFFSet:LIST:STATe command.

Factory Preset:

Mode	Offset A	Offset B	Offset C	Offset D	Offset E
Basic (E4406A)	RMS	RMS	RMS	RMS	RMS
cdmaOne	RMS	RMS	RMS	RMS	RMS

Remarks: You must be in Basic (E4406A), or cdmaOne mode to use this command. Use INSTRument:SELEct to set the mode.

History: (E4406A):
Revision A.03.00 or later, in cdmaOne revision A.04.00

Adjacent Channel Power—Define Resolution Bandwidth List

iDEN mode (E4406A)

```
[ :SENSe ] :ACP:OFFSet:BANDwidth | BWIDth <res_bw>
```

```
[ :SENSe ] :ACP:OFFSet:BANDwidth | BWIDth?
```

Basic mode (E4406A)

```
[ :SENSe ] :ACP:OFFSet:LIST:BANDwidth | BWIDth  
<res_bw>, <res_bw>, <res_bw>, <res_bw>, <res_bw>
```

```
[ :SENSe ] :ACP:OFFSet:LIST:BANDwidth | BWIDth?
```

cdma2000, W-CDMA mode

```
[ :SENSe ] :ACP:OFFSet[n]:LIST:BANDwidth | BWIDth  
<res_bw>, <res_bw>, <res_bw>, <res_bw>, <res_bw>
```

```
[ :SENSe ] :ACP:OFFSet[n]:LIST:BANDwidth | BWIDth?
```

cdmaOne mode

```
[ :SENSe ] :ACP:OFFSet[n]:LIST[n]:BANDwidth | BWIDth  
<res_bw>, <res_bw>, <res_bw>, <res_bw>, <res_bw>
```

```
[ :SENSe ] :ACP:OFFSet[n]:LIST[n]:BANDwidth | BWIDth?
```

Define the custom resolution bandwidth(s) for the adjacent channel power testing. If there is more than one bandwidth, the list must contain five (5) entries. Each resolution bandwidth in the list corresponds to an offset frequency in the list defined by [:SENSe]:ACP:OFFSet[n]:LIST[n]:FREQUency]. You can turn off (not use) specific offsets with the [:SENSe]:ACP:OFFSet[n]:LIST[n]:STATe command.

SENSe Subsystem

Offset[n] n=1 is base station and 2 is mobiles. The default is base station (1).

List[n] n=1 is cellular bands and 2 is pcs bands. The default is cellular.

Factory Preset:

Mode	Variant	Offset A	Offset B	Offset C	Offset D	Offset E
iDEN (E4406A)		10 kHz	n/a	n/a	n/a	n/a
Basic (E4406A)		30 kHz	30 kHz	30 kHz	30 kHz	30 kHz
cdmaOne	BS cellular	30 kHz	30 kHz	30 kHz	30 kHz	30 kHz
	BS pcs	30 kHz	12.5 kHz	1 MHz	30 kHz	30 kHz
	MS cellular	30 kHz	30 kHz	30 kHz	30 kHz	30 kHz
	MS pcs	30 kHz	12.5 kHz	1 MHz	30 kHz	30 kHz
cdma2000		30 kHz	30 kHz	30 kHz	30 kHz	30 kHz
W-CDMA		3.84 MHz	3.84 MHz	3.84 MHz	3.84 MHz	3.84 MHz

Range: 300 Hz to 20 MHz for cdmaOne, Basic, cdma2000, W-CDMA mode

1 kHz to 5 MHz for iDEN mode (E4406A)

Default Unit: Hz

Remarks: For PSA you must be in cdmaOne, cdma2000, or W-CDMA mode to use this command. Use INSTRument:SElect to set the mode.

For E4406A you must be in Basic, cdmaOne, cdma2000, W-CDMA, or iDEN mode to use this command. Use INSTRument:SElect to set the mode.

Adjacent Channel Power—FFT Segments

```
[ :SENSe ] :ACP:OFFSet:LIST:FFTSegment
<integer>,<integer>,<integer>,<integer>,<integer>
```

```
[ :SENSe ] :ACP:OFFSet:LIST:FFTSegment?
```

Selects the number of FFT segments used in making the measurement. In automatic mode the measurement optimizes the number of FFT segments required for the shortest measurement time. The minimum number of segments required to make a measurement is set by your desired measurement bandwidth. Selecting more than the minimum number of segments will give you more dynamic range for making the measurement, but the measurement will take longer to execute.

Factory Preset:

Mode	Offset A	Offset B	Offset C	Offset D	Offset E
Basic (E4406A)	1	1	1	1	1
cdmaOne	1	1	1	1	1

Range: 1 to 12

Remarks: You must be in Basic (E4406A), or cdmaOne mode to use this command. Use INSTRument:SElect to set the mode.

History: E4406A:
Revision A.03.00 or later, in cdmaOne revision A.04.00

Adjacent Channel Power—Automatic FFT Segments

```
[ :SENSe ]:ACP:OFFSet:LIST:FFTSegment:AUTO OFF|ON|0|1,
OFF|ON|0|1, OFF|ON|0|1, OFF|ON|0|1, OFF|ON|0|1
```

```
[ :SENSe ]:ACP:OFFSet:LIST:FFTSegment:AUTO?
```

The automatic mode selects the optimum number of FFT segments to make the fastest possible measurement.

Factory Preset:

Mode	Offset A	Offset B	Offset C	Offset D	Offset E
Basic (E4406A)	ON	ON	ON	ON	ON
cdmaOne	ON	ON	ON	ON	ON

Remarks: You must be in Basic (E4406A), or cdmaOne mode to use this command. Use INSTRument:SElect to set the mode.

History: E4406A:
Revision A.03.00 or later

Adjacent Channel Power—Define Offset Frequency List

iDEN mode (E4406A)

```
[ :SENSe ]:ACP:OFFSet[:FREQuency] <f_offset>
```

```
[ :SENSe ]:ACP:OFFSet[:FREQuency]?
```

Basic mode (E4406A)

```
[ :SENSe ]:ACP:OFFSet:LIST[:FREQuency]
<f_offset>,<f_offset>,<f_offset>,<f_offset>,<f_offset>
```

SENSe Subsystem

`[:SENSe] :ACP:OFFSet:LIST[:FREQuency]?`

cdma2000, W-CDMA mode

`[:SENSe] :ACP:OFFSet[n]:LIST[:FREQuency]`
`<f_offset>,<f_offset>,<f_offset>,<f_offset>,<f_offset>`

`[:SENSe] :ACP:OFFSet[n]:LIST[:FREQuency]?`

cdmaOne mode

`[:SENSe] :ACP:OFFSet[n]:LIST[n][:FREQuency]`
`<f_offset>,<f_offset>,<f_offset>,<f_offset>,<f_offset>`

`[:SENSe] :ACP:OFFSet[n]:LIST[n][:FREQuency]?`

Define the custom set of offset frequencies at which the switching transient spectrum part of the ACP measurement will be made. The list contains five (5) entries for offset frequencies. Each offset frequency in the list corresponds to a reference bandwidth in the bandwidth list.

An offset frequency of zero turns the display of the measurement for that offset off, but the measurement is still made and reported. You can turn off (not use) specific offsets with the `[:SENSe] :ACP:OFFSet:LIST:STATe` command.

Offset[n] n=1 is base station and 2 is mobiles. The default is base station (1).

List[n] n=1 is cellular bands and 2 is pcs bands. The default is cellular.

Factory Preset:

Mode	Variant	Offset A	Offset B	Offset C	Offset D	Offset E
iDEN (E4406A)		25 kHz	n/a	n/a	n/a	n/a
Basic (E4406A)		750 kHz	1.98 MHz	0 Hz	0 Hz	0 Hz
cdmaOne	BS cellular	750 kHz	1.98 MHz	0 Hz	0 Hz	0 Hz
	BS pcs	885 kHz	1.25625 MHz	2.75 MHz	0 Hz	0 Hz
	MS cellular	885 kHz	1.98 MHz	0 Hz	0 Hz	0 Hz
	MS pcs	1.265 MHz	0 Hz	0 Hz	0 Hz	0 Hz
cdma2000	BTS	750 kHz	1.98 MHz	0 Hz	0 Hz	0 Hz
	MS	885 kHz	1.98 MHz	0 Hz	0 Hz	0 Hz
W-CDMA		5 MHz	10 MHz	15 MHz	20 MHz	25 MHz

Range: 0 Hz to 45 MHz for cdmaOne

0 Hz to 20 MHz for iDEN, Basic (E4406A)

0 Hz to 100 MHz for cdma2000, W-CDMA

Default Unit: Hz

Remarks: For E4406A you must be in Basic, cdmaOne, cdma2000, W-CDMA, or iDEN mode to use this command. Use INSTRument:SElect to set the mode.

Adjacent Channel Power—Number of Measured Points

[:SENSe] :ACP:OFFSet:LIST:POINTs
<integer>,<integer>,<integer>,<integer>,<integer>

[:SENSe] :ACP:OFFSet:LIST:POINTs?

Selects the number of data points. The automatic mode chooses the optimum number of points for the fastest measurement time with acceptable repeatability. The minimum number of points that could be used is determined by the sweep time and the sampling rate. You can increase the length of the measured time record (capture more of the burst) by increasing the number of points, but the measurement will take longer. Use **[:SENSe] :ACP:POINTs** to set the number of points used for measuring the reference channel.

Factory Preset:

Mode	Offset A	Offset B	Offset C	Offset D	Offset E
Basic (E4406A)	1024	1024	1024	1024	1024
cdmaOne	1024	1024	1024	1024	1024

Range: 64 to 65536

Remarks: The fastest measurement times are obtained when the number of points measured is 2^n .

You must be in Basic (E4406A), or cdmaOne mode to use this command. Use INSTRument:SElect to set the mode.

History: E4406A:
Revision A.03.00 or later, in cdmaOne revision A.04.00

Adjacent Channel Power—Automatic Measurement Points

[:SENSe] :ACP:OFFSet:LIST:POINTs:AUTO OFF|ON|0|1,
OFF|ON|0|1, OFF|ON|0|1, OFF|ON|0|1, OFF|ON|0|1

[:SENSe] :ACP:OFFSet:LIST:POINTs:AUTO?

Automatically selects the number of points for the optimum measurement speed.

SENSE Subsystem

Factory Preset:

Mode	Offset A	Offset B	Offset C	Offset D	Offset E
Basic (E4406A)	ON	ON	ON	ON	ON
cdmaOne	ON	ON	ON	ON	ON

Remarks: You must be in Basic (E4406A), or cdmaOne mode to use this command. Use INSTRument:SElect to set the mode.

History: E4406A:
Revision A.03.00 or later, in cdmaOne revision A.04.00

Adjacent Channel Power—Relative Attenuation

```
[ :SENSE ] : ACP : OFFSet : LIST : RATTenuation  
<rel_powr> , <rel_powr> , <rel_powr> , <rel_powr> , <rel_powr>
```

```
[ :SENSE ] : ACP : OFFSet : LIST : RATTenuation?
```

Sets a relative amount of attenuation for the measurements made at your offsets. The amount of attenuation is always specified relative to the attenuation that is required to measure the carrier channel. Since the offset channel power is lower than the carrier channel power, less attenuation is required to measure the offset channel and you get wider dynamic range for the measurement.

You can turn off (not use) specific offsets with the SENS:ACP:OFFSet:LIST:STATe command.

Factory Preset:

Mode	Offset A	Offset B	Offset C	Offset D	Offset E
Basic (E4406A)	0 dB	0 dB	0 dB	0 dB	0 dB
cdmaOne	0 dB	0 dB	0 dB	0 dB	0 dB

Range: –40 to 0 dB, but this relative attenuation cannot exceed the absolute attenuation range of 0 to 40 dB.

Default Unit: dB

Remarks: Remember that the attenuation that you specify is always relative to the amount of attenuation used for the carrier channel. Selecting negative attenuation means that you want less attenuation used. For example, if the measurement must use 20 dB of attenuation for the carrier measurement and you want to use 12 dB less attenuation for the first offset, you would send the value –12 dB.

You must be in Basic (E4406A), or cdmaOne mode to use this command. Use INSTRument:SElect to set the mode.

History: E4406A:
Revision A.03.00 or later, in cdmaOne revision A.04.00

Adjacent Channel Power—Relative Attenuation Control

```
[ :SENSe]:ACP:OFFSet:LIST:RATTenuation:AUTO OFF|ON|0|1
```

```
[ :SENSe]:ACP:OFFSet:LIST:RATTenuation:AUTO?
```

Automatically sets a relative attenuation to make measurements with the optimum dynamic range at the current carrier channel power.

You can turn off (not use) specific offsets with the SENS:ACP:OFFSet:LIST:STATe command.

Factory Preset: ON

Remarks: You must be in Basic (E4406A), or cdmaOne mode to use this command. Use INSTRument:SElect to set the mode.

History: E4406A:
Revision A.03.00 or later, in cdmaOne revision A.04.00.

Adjacent Channel Power—Amplitude Limits Relative to the Carrier

iDEN mode (E4406A)

```
[ :SENSe]:ACP:OFFSet:RCARrier <rel_power>
```

```
[ :SENSe]:ACP:OFFSet:RCARrier?
```

Basic mode (E4406A)

```
[ :SENSe]:ACP:OFFSet:LIST:RCARrier  
<rel_power>,<rel_power>,<rel_power>,<rel_power>,<rel_power>
```

```
[ :SENSe]:ACP:OFFSet:LIST:RCARrier?
```

cdma2000, W-CDMA mode

```
[ :SENSe]:ACP:OFFSet[n]:LIST:RCARrier  
<rel_power>,<rel_power>,<rel_power>,<rel_power>,<rel_power>
```

```
[ :SENSe]:ACP:OFFSet[n]:LIST:RCARrier?
```

cdmaOne mode

```
[ :SENSe]:ACP:OFFSet[n]:LIST[n]:RCARrier  
<rel_power>,<rel_power>,<rel_power>,<rel_power>,<rel_power>
```

```
[ :SENSe]:ACP:OFFSet[n]:LIST[n]:RCARrier?
```

Sets the amplitude levels to test against for any custom offsets. This amplitude level is relative to the carrier amplitude. If multiple offsets are available, the list contains five (5) entries. The offset closest to the carrier channel is the first one in

SENSE Subsystem

the list. [:SENSE]:ACP:OFFSet[n]:LIST[n]:TEST selects the type of testing to be done at each offset.

You can turn off (not use) specific offsets with the [:SENSE]:ACP:OFFSet[n]:LIST[n]:STATe command.

The query returns the five (5) sets of the real numbers that are the current amplitude test limits, relative to the carrier, for each offset.

Offset[n] n=1 is base station and 2 is mobiles. The default is base station (1).

List[n] n=1 is cellular bands and 2 is pcs bands. The default is cellular.

Factory Preset:

Mode	Variant	Offset A	Offset B	Offset C	Offset D	Offset E
iDEN (E4406A)		0 dBc	n/a	n/a	n/a	n/a
Basic (E4406A)		-45 dBc	-60 dBc	0 dBc	0 dBc	0 dBc
cdmaOne	BS cellular	-45 dBc	-60 dBc	0 dBc	0 dBc	0 dBc
	BS pcs	-45 dBc	0 dBc	0 dBc	0 dBc	0 dBc
	MS cellular	-42 dBc	-54 dBc	0 dBc	0 dBc	0 dBc
	MS pcs	-42 dBc	0 dBc	0 dBc	0 dBc	0 dBc
cdma2000		0 dBc	0 dBc	0 dBc	0 dBc	0 dBc
W-CDMA	BTS	-44.2 dBc	-49.2 dBc	-49.2 dBc	-49.2 dBc	-49.2 dBc
	MS	-32.2 dBc	-42.2 dBc	-42.2 dBc	-42.2 dBc	-42.2 dBc

Range: -150.0 dB to 50.0 dB for cdmaOne, cdma2000, W-CDMA, Basic (E4406A)

-200.0 dB to 50.0 dB for iDEN (E4406A)

Default Unit: dB

Remarks: For E4406A you must be in Basic, cdmaOne, cdma2000, W-CDMA, or iDEN mode to use this command. Use INSTRument:SElect to set the mode.

Adjacent Channel Power—Amplitude Limits Relative to the Power Spectral Density

iDEN mode (E4406A)

[:SENSE]:ACP:OFFSet:RPSDensity <rel_power>

[:SENSE]:ACP:OFFSet:RPSDensity?

Basic mode (E4406A)

```
[ :SENSe]:ACP:OFFSet:LIST:RPSDensity
<rel_power>,<rel_power>,<rel_power>,<rel_power>,<rel_power>
```

```
[ :SENSe]:ACP:OFFSet:LIST:RPSDensity?
```

cdma2000, W-CDMA mode

```
[ :SENSe]:ACP:OFFSet[n]:LIST:RPSDensity
<rel_power>,<rel_power>,<rel_power>,<rel_power>,<rel_power>
```

```
[ :SENSe]:ACP:OFFSet[n]:LIST:RPSDensity?
```

cdmaOne mode

```
[ :SENSe]:ACP:OFFSet[n]:LIST[n]:RPSDensity
<rel_power>,<rel_power>,<rel_power>,<rel_power>,<rel_power>
```

```
[ :SENSe]:ACP:OFFSet[n]:LIST[n]:RPSDensity?
```

Sets the amplitude levels to test against for any custom offsets. This amplitude level is relative to the power spectral density. If multiple offsets are available, the list contains five (5) entries. The offset closest to the carrier channel is the first one in the list. [:SENSe]:ACP:OFFSet[n]:LIST[n]:TEST selects the type of testing to be done at each offset.

You can turn off (not use) specific offsets with the [:SENSe]:ACP:OFFSet[n]:LIST:STATE command.

The query returns the five (5) sets of the real numbers that are the current amplitude test limits, relative to the power spectral density, for each offset.

Offset[n] n=1 is base station and 2 is mobiles. The default is base station (1).

List[n] n=1 is cellular bands and 2 is pcs bands. The default is cellular.

Factory Preset:

Mode	Variant	Offset A	Offset B	Offset C	Offset D	Offset E
iDEN (E4406A)		0 dB	n/a	n/a	n/a	n/a
Basic (E4406A)		-28.87 dB	-43.87 dB	0 dB	0 dB	0 dB
cdmaOne	BS cellular	-28.87 dB	-43.87 dB	0 dB	0 dB	0 dB
	BS pcs	-28.87 dB	0 dB	0 dB	0 dB	0 dB
	MS cellular	-25.87 dB	-37.87 dB	0 dB	0 dB	0 dB
	MS pcs	-25.87 dB	0 dB	0 dB	0 dB	0 dB
cdma2000		0 dB	0 dB	0 dB	0 dB	0 dB
W-CDMA	BTS	-44.2 dBc	-49.2 dBc	-49.2 dBc	-49.2 dBc	-49.2 dBc
	MS	-32.2 dBc	-42.2 dBc	-42.2 dBc	-42.2 dBc	-42.2 dBc

SENSe Subsystem

Range: -150.0 dB to 50.0 dB for cdmaOne, Basic, cdma2000, W-CDMA
-200.0 dB to 50.0 dB for iDEN (E4406A)

Default Unit: dB

Remarks: For E4406A you must be in Basic, cdmaOne, cdma2000, W-CDMA, or iDEN mode to use this command. Use INSTRument:SElect to set the mode.

Adjacent Channel Power—Select Sideband

```
[ :SENSe ] :ACP:OFFSet:LIST:SIDE BOTH|NEGative|POSitive,  
BOTH|NEGative|POSitive, BOTH|NEGative|POSitive,  
BOTH|NEGative|POSitive, BOTH|NEGative|POSitive
```

```
[ :SENSe ] :ACP:OFFSet:LIST:SIDE?
```

Selects which sideband will be measured. You can turn off (not use) specific offsets with the SENS:ACP:OFFSet:LIST:STATe command.

Factory Preset:

Mode	Offset A	Offset B	Offset C	Offset D	Offset E
Basic (E4406A)	BOTH	BOTH	BOTH	BOTH	BOTH
cdmaOne	BOTH	BOTH	BOTH	BOTH	BOTH

Remarks: You must be in Basic (E4406A), or cdmaOne mode to use this command. Use INSTRument:SElect to set the mode.

History: E4406A:
Revision A.03.00 or later, in cdmaOne revision A.04.00

Adjacent Channel Power—Control Offset Frequency List

Basic mode (E4406A)

```
[ :SENSe ] :ACP:OFFSet:LIST:STATe OFF|ON|0|1, OFF|ON|0|1,  
OFF|ON|0|1, OFF|ON|0|1, OFF|ON|0|1
```

```
[ :SENSe ] :ACP:OFFSet:LIST:STATe?
```

cdma2000, W-CDMA mode

```
[ :SENSe ] :ACP:OFFSet[n]:LIST:STATe OFF|ON|0|1, OFF|ON|0|1,  
OFF|ON|0|1, OFF|ON|0|1, OFF|ON|0|1
```

```
[ :SENSe ] :ACP:OFFSet[n]:LIST:STATe?
```

cdmaOne mode

```
[ :SENSe ] : ACP : OFFSet [ n ] : LIST [ n ] : STATE OFF | ON | 0 | 1 ,
OFF | ON | 0 | 1 , OFF | ON | 0 | 1 , OFF | ON | 0 | 1 , OFF | ON | 0 | 1
```

```
[ :SENSe ] : ACP : OFFSet [ n ] : LIST [ n ] : STATE ?
```

Selects whether testing is to be done at the custom offset frequencies. The measured powers are tested against the absolute values defined with [:SENSe]:ACP:OFFSet:LIST:ABSolute, or the relative values defined with [:SENSe]:ACP:OFFSet:LIST:RPSDensity and [:SENSe]:ACP:OFFSet:LIST:RCARier.

Offset[n] n=1 is base station and 2 is mobiles. The default is base station (1).

List[n] n=1 is cellular bands and 2 is pcs bands. The default is cellular.

Factory Preset:

Mode	Variant	Offset A	Offset B	Offset C	Offset D	Offset E
Basic (E4406A)		On	On	On	On	On
cdmaOne	BS cellular	On	On	On	On	On
	BS pcs	On	On	On	On	On
	MS cellular	On	On	On	On	On
	MS pcs	On	On	On	On	On
cdma2000		On	On	Off	Off	Off
W-CDMA		On	On	Off	Off	Off

Remarks: For PSA and E4406A you must be in Basic (E4406A), cdmaOne, cdma2000, or W-CDMA mode to use this command. Use INSTRument:SElect to set the mode.

Adjacent Channel Power—Sweep Time

```
[ :SENSe ] : ACP : OFFSet : LIST : SWEEp : TIME
<seconds> , <seconds> , <seconds> , <seconds> , <seconds>
```

```
[ :SENSe ] : ACP : OFFSet : LIST : SWEEp : TIME ?
```

Selects a specific sweep time. If you increase the sweep time, you increase the length of the time data captured and the number of points measured. You might need to specify a specific sweep speed to accommodate a specific condition in your transmitter. For example, you may have a burst signal and need to measure an exact portion of the burst.

Selecting a specific sweep time may result in a long measurement time since the resulting number of data points may not be the optimum 2^n . Use

```
[ :SENSe ] : ACP : SWEEp : TIME
```

to set the number of points used for measuring the

SENSe Subsystem

reference channel.

You can turn off (not use) specific offsets with the SENS:ACP:OFFSet:LIST:STATe command.

Factory Preset:

Mode	Offset A	Offset B	Offset C	Offset D	Offset E
Basic (E4406A)	11.20 ms	11.20 ms	11.20 ms	11.20 ms	11.20 ms
cdmaOne	11.20 ms	11.20 ms	11.20 ms	11.20 ms	11.20 ms

Range: 1 μ s to 50 ms

Default Unit: seconds

Remarks: You must be in Basic (E4406A), or cdmaOne mode to use this command. Use INSTRument:SELEct to set the mode.

History: E4406A:
Revision A.03.00 or later, in cdmaOne revision A.04.00

Adjacent Channel Power—Automatic Sweep Time

```
[ :SENSe ] :ACP:OFFSet:LIST:SWEep:TIME:AUTO OFF|ON|0|1,  
OFF|ON|0|1, OFF|ON|0|1, OFF|ON|0|1, OFF|ON|0|1
```

```
[ :SENSe ] :ACP:OFFSet:LIST:SWEep:TIME:AUTO?
```

Sets the sweep time to be automatically coupled for the fastest measurement time. You can turn off (not use) specific offsets with the SENS:ACP:OFFSet:LIST:STATe command.

Factory Preset:

Mode	Offset A	Offset B	Offset C	Offset D	Offset E
Basic (E4406A)	On	On	On	On	On
cdmaOne	On	On	On	On	On

Remarks: You must be in Basic (E4406A), or cdmaOne mode to use this command. Use INSTRument:SELEct to set the mode.

History: E4406A:
Revision A.03.00 or later, in cdmaOne revision A.04.00

Adjacent Channel Power—Define Type of Offset Frequency List

iDEN mode (E4406A)

```
[ :SENSe ] :ACP:OFFSet:TEST ABSolute|AND|OR|RELative
```

```
[ :SENSe]:ACP:OFFSet:TEST?
```

Basic mode (E4406A)

```
[ :SENSe]:ACP:OFFSet:LIST:TEST ABSolute|AND|OR|RELative,
ABSolute|AND|OR|RELative, ABSolute|AND|OR|RELative,
ABSolute|AND|OR|RELative, ABSolute|AND|OR|RELative
```

```
[ :SENSe]:ACP:OFFSet:LIST:TEST?
```

cdma2000, W-CDMA mode

```
[ :SENSe]:ACP:OFFSet[n]:LIST:TEST ABSolute|AND|OR|RELative,
ABSolute|AND|OR|RELative, ABSolute|AND|OR|RELative,
ABSolute|AND|OR|RELative, ABSolute|AND|OR|RELative
```

```
[ :SENSe]:ACP:OFFSet[n]:LIST:TEST?
```

cdmaOne mode

```
[ :SENSe]:ACP:OFFSet[n]:LIST[n]:TEST,
ABSolute|AND|OR|RELative,
ABSolute|AND|OR|RELative, ABSolute|AND|OR|RELative,
ABSolute|AND|OR|RELative
```

```
[ :SENSe]:ACP:OFFSet[n]:LIST[n]:TEST?
```

Defines the type of testing to be done at any custom offset frequencies. The measured powers are tested against the absolute values defined with [:SENSe]:ACP:OFFSet[n]:LIST:ABSolute, or the relative values defined with [:SENSe]:ACP:OFFSet:LIST:RPSDensity and [:SENSe]:ACP:OFFSet:LIST:RCARrier.

You can turn off (not use) specific offsets with the [:SENS]:ACP:OFFSet:LIST:STATe command.

Offset[n] n=1 is base station and 2 is mobiles. The default is base station (1).

List[n] n=1 is cellular bands and 2 is pcs bands. The default is cellular.

The types of testing that can be done for each offset include:

- Absolute - Test the absolute power measurement. If it fails, then return a failure for the measurement at this offset.
- And - Test both the absolute power measurement and the power relative to the carrier. If they both fail, then return a failure for the measurement at this offset.
- Or - Test both the absolute power measurement and the power relative to the carrier. If either one fails, then return a failure for the measurement at this offset.
- Relative - Test the power relative to the carrier. If it fails, then return a failure for the measurement at this offset.
- OFF - Turns the power test off.

SENSe Subsystem

Factory Preset:

Mode	Variant	Offset A	Offset B	Offset C	Offset D	Offset E
iDEN (E4406A)		REL	n/a	n/a	n/a	n/a
Basic (E4406A)		REL	REL	REL	REL	REL
cdmaOne	BS cellular	REL	REL	REL	REL	REL
	BS pcs	REL	ABS	ABS	REL	REL
	MS cellular	REL	REL	REL	REL	REL
	MS pcs	REL	ABS	ABS	REL	REL
cdma2000		REL	REL	REL	REL	REL
W-CDMA		REL	REL	REL	REL	REL

Remarks: For E4406A you must be in Basic, cdmaOne, cdma2000, W-CDMA, or iDEN mode to use this command. Use INSTRument:SElect to set the mode.

Adjacent Channel Power—Number of Measured Points

[:SENSe] :ACP :POINTs <integer>

[:SENSe] :ACP :POINTs?

Selects the number of data points used to measure the reference (carrier) channel. The automatic mode chooses the optimum number of points for the fastest measurement time with acceptable repeatability. The minimum number of points that could be used is determined by the sweep time and the sampling rate.

You can increase the length of the measured time record (capture more of the burst) by increasing the number of points, but the measurement will take longer. Use [:SENSe] :ACP :OFFSet :LIST :POINTs to set the number of points used for measuring the offset channels.

Factory Preset: 1024

Remarks: The fastest measurement times are obtained when the number of points measured is 2^n .

You must be in Basic (E4406A), or cdmaOne mode to use this command. Use INSTRument:SElect to set the mode.

Range: 64 to 65536

History: E4406A:
Revision A.03.00 or later, in cdmaOne revision A.04.00

Adjacent Channel Power—Automatic Measurement Points

```
[ :SENSE]:ACP:POINTS:AUTO OFF|ON|0|1
```

```
[ :SENSE]:ACP:POINTS:AUTO?
```

Automatically selects the number of points for the optimum measurement speed.

Factory Preset: ON

Remarks: You must be in Basic (E4406A), or cdmaOne mode to use this command. Use INSTRUMENT:SELEct to set the mode.

History: E4406A:
Revision A.03.00 or later, in cdmaOne revision A.04.00

Adjacent Channel Power—Spectrum Trace Control

```
[ :SENSE]:ACP:SPECTRUM:ENABLE OFF|ON|0|1
```

```
[ :SENSE]:ACP:SPECTRUM:ENABLE?
```

Turns on/off the measurement of the spectrum trace data when the spectrum view is selected. (Select the view with DISPLAY:ACP:VIEW.) You may want to disable the spectrum trace data part of the measurement so you can increase the speed of the rest of the measurement data.

Factory Preset: ON

Remarks: You must be in Basic (E4406A), cdmaOne, or iDEN (E4406A) mode to use this command. Use INSTRUMENT:SELEct to set the mode.

History: E4406A:
Revision A.03.27 or later, in cdmaOne revision A.04.00

Adjacent Channel Power—Sweep Mode Resolution Bandwidth

```
[ :SENSE]:ACP:SWEep:BANDwidth|BWIDth[:RESolution] <freq>
```

```
[ :SENSE]:ACP:SWEep:BANDwidth|BWIDth[:RESolution]?
```

Sets the resolution bandwidth when using the spectrum analyzer type sweep mode. See [:SENSE]:ACP:SWEep:TYPE.

Factory Preset: Auto coupled.

Range: 1.0 kHz to 1.0 MHz

Resolution: 1.0 kHz

Step Size: 1.0 kHz

Default Unit: Hz

Remarks: You must be in the cdmaOne cdma2000, or W-CDMA mode to

SENSe Subsystem

use this command. Use INSTRument:SElect to set the mode.

Adjacent Channel Power—Sweep Mode Resolution BW Control

```
[ :SENSe ] :ACP :SWEep :BANDwidth | BWIDth [ :RESolution ] :AUTO  
OFF | ON | 0 | 1
```

```
[ :SENSe ] :ACP :SWEep :BANDwidth | BWIDth [ :RESolution ] :AUTO?
```

Sets the resolution bandwidth to automatic, when using the spectrum analyzer type sweep mode. See [:SENSe] :ACP :SWEep :TYPE.

Factory Preset: ON

Remarks: You must be in the cdmaOne cdma2000, or W-CDMA mode to use this command. Use INSTRument:SElect to set the mode.

Adjacent Channel Power—Sweep Mode Detection

```
[ :SENSe ] :ACP :SWEep :DETEctor [ :FUNction ] AAverage | POSitive
```

```
[ :SENSe ] :ACP :SWEep :DETEctor [ :FUNction ] ?
```

Selects the detector type when using the sweep mode. See [:SENSe] :ACP :SWEep :TYPE.

Absolute average (AAverage) - the absolute average power in each frequency is measured across the spectrum

Positive - the positive peak power in each frequency is measured across the spectrum

Factory Preset: POSitive

Remarks: You must be in the cdma2000, or W-CDMA mode to use this command. Use INSTRument:SElect to set the mode.

Adjacent Channel Power—Sweep Time

```
[ :SENSe ] :ACP :SWEep :TIME <seconds>
```

```
[ :SENSe ] :ACP :SWEep :TIME ?
```

Selects a specific sweep time used to measure the reference (carrier) channel. If you increase the sweep time, you increase the length of the time data captured and the number of points measured. You might need to specify a specific sweep speed to accommodate a specific condition in your transmitter. For example, you may have a burst signal and need to measure an exact portion of the burst.

Selecting a specific sweep time may result in a long measurement time since the resulting number of data points may not be the optimum 2^n . Use

```
[ :SENSe ] :ACP :OFFSet :LIST :SWEep :TIME
```

 to set the number of points used

for measuring the offset channels for Basic and cdmaOne.

For cdma2000 and W-CDMA, this command sets the sweep time when using the sweep mode. See [**:SENSe**] : **ACP** : **SWEep** : **TYPE**.

Factory Preset: 625 μ s (1 slot) for W-CDMA
 1.25 ms for cdma2000
 11.20 ms for Basic, cdmaOne

Range: 500 μ s to 10 ms for W-CDMA, cdma2000
 1 μ s to 50 ms for Basic (E4406A), cdmaOne

Default Unit: seconds

Remarks: You must be in the Basic (E4406A), cdmaOne, cdma2000, or W-CDMA mode to use this command. Use INSTRument:SElect to set the mode.

History: E4406A:
 Added to Basic revision A.03.00, to cdmaOne revision A.04.00

Adjacent Channel Power—Automatic Sweep Time

[**:SENSe**] : **ACP** : **SWEep** : **TIME** : **AUTO** OFF | ON | 0 | 1

[**:SENSe**] : **ACP** : **SWEep** : **TIME** : **AUTO**?

Sets the sweep time to be automatically coupled for the fastest measurement time.

Factory Preset: ON

Remarks: You must be in Basic (E4406A), or cdmaOne mode to use this command. Use INSTRument:SElect to set the mode.

History: E4406A:
 Revision A.03.00 or later, in cdmaOne revision A.04.00

Adjacent Channel Power—Sweep Type

W-CDMA mode

[**:SENSe**] : **ACP** : **SWEep** : **TYPE** FAST | FFT | SWEep

[**:SENSe**] : **ACP** : **SWEep** : **TYPE**?

cdma2000 mode

[**:SENSe**] : **ACP** : **SWEep** : **TYPE** FFT | SWEep

[**:SENSe**] : **ACP** : **SWEep** : **TYPE**?

Selects the type of sweeping.

Fast (*W-CDMA mode only*) - the data acquisition is made with the wide channel

SENSe Subsystem

integration bandwidth and the time-domain data is divided into the narrow data to apply FFT. This mode is faster than the FFT mode but less accurate in power levels.

FFT - the data acquisition is made with the narrow channel integration bandwidth and apply fast Fourier transform (FFT) to convert to the frequency domain data.

Sweep - the measurement is made by the swept spectrum method like the traditional swept frequency spectrum analysis to have better correlation to the input signal with a high crest factor (peak/average ratio). This mode may take a longer time than the FFT mode. See

[:SENSe] :ACP :SWEep :DETector [:FUNction].

Factory Preset: FFT

Remarks: You must be in the cdma2000, or W-CDMA mode to use this command. Use INSTRument:SElect to set the mode.

Adjacent Channel Power—Trigger Source

**[:SENSe] :ACP :TRIGger :SOURce
EXtErnal [1] | EXtErnal2 | FRAMe | IF | IMMEdiate | RFBurst**

[:SENSe] :ACP :TRIGger :SOURce?

Select the trigger source used to control the data acquisitions.

EXtErnal 1 – front panel external trigger input

EXtErnal 2 – rear panel external trigger input

FRAMe – internal frame trigger from front panel input

IF – internal IF envelope (video) trigger

IMMEdiate – the next data acquisition is immediately taken, capturing the signal asynchronously (also called free run).

RFBurst – wideband RF burst envelope trigger that has automatic level control for periodic burst signals.

Factory Preset: IMMEdiate for BS

RFBurst for MS

Remarks: For E4406A you must be in Basic, cdmaOne, iDEN, NADC, or PDC mode to use this command. Use INSTRument:SElect to set the mode.

In Basic mode, for offset frequencies >12.5 MHz, the external triggers will be a more reliable trigger source than RF burst. Also, you can use the Waveform measurement to set up trigger delay.

History: E4406A:
Added revision A.04.00 or later

Adjacent Channel Power—Power Reference

[:SENSE] : ACP : TYPE PSDRef | TPreF

[:SENSE] : ACP : TYPE?

Selects the measurement type. This allows you to make absolute and relative power measurements of either total power or the power normalized to the measurement bandwidth.

Power Spectral Density Reference (PSDRef) - the power spectral density is used as the power reference

Total Power Reference (TPRef) - the total power is used as the power reference

Factory Preset: Total power reference (TPRef)

Remarks:

For E4406A you must be in the Basic, cdmaOne, cdma2000, W-CDMA, NADC, or PDC mode to use this command. Use INSTRument:SElect to set the mode.

Baseband I/Q Commands (E4406A only)

Baseband I/Q - Select I/Q Power Range

[:SENSe] :POWer :IQ :RANGe [:UPPer] <power> [DBM] | DBMV | W

[:SENSe] :POWer :IQ :RANGe [:UPPer] ?

Selects maximum total power expected from unit under test at test port when I or Q port is selected.

Range: For 50 Ohms:

13.0, 7.0, 1.0, or -5.1 dBm
60.0, 54.0, 48.0, or 41.9 dBmV
0.02, 0.005, 0.0013, or 0.00031 W

For 600 Ohms:

2.2, -3.8, -9.8, or -15.8 dBm
60.0, 54.0, 48.0, or 41.9 dBmV
0.0017, 0.00042, 0.0001, or 0.000026 W

For 1 M Ohm:

Values for 1 M Ohm vary according to selected reference impedance.

Default Units: DBM

Remarks: You must be in the Basic, W-CDMA, cdma2000 mode to use this command. Use INSTRument:SElect to set the mode.

History: Added revision A.05.00

Baseband I/Q - Select I/Q Voltage Range

[:SENSe] :VOLTagE :IQ :RANGe [:UPPer] <level>

[:SENSe] :VOLTagE :IQ :RANGe [:UPPer] ?

Selects upper voltage range when I or Q port is selected. This setting helps set the gain which is generated in the variable gain block of the baseband IQ board to improve dynamic range.

Range: 1.0, 0.5, .025, or 0.125 volts

Default Units: V

Remarks: You must be in the Basic, W-CDMA, cdma2000 mode to use this command. Use INSTRument:SElect to set the mode.

History: Added revision A.05.00

Code Domain Measurement

Commands for querying the code domain power measurement results and for setting to the default values are found in the “MEASure Group of Commands” on [page 193](#). The equivalent front panel keys for the parameters described in the following commands, are found under the **Meas Setup** key, after the **Code Domain** measurement has been selected from the **MEASURE** key menu.

Code Domain Measurement — Active Data Channel

```
[ :SENSe ] :CDPower :ACODE AUTO | PREDeFined
```

```
[ :SENSe ] :CDPower :ACODE?
```

Select the Active Channel ID detection mode Auto or Predefined.

AUTO - detects Active Channel ID for Data Channel automatically.

PREDeFined - set predefined Active Channel (all channel codes) for Data Channel.

Factory Preset: AUTO

Remarks: You must be in the 1xEV-DO mode to use this command. Use INSTRument:SElect to set the mode.

Code Domain Measurement — ADC Range

PSA

```
[ :SENSe ] :CDPower :ADC :RANGe
```

```
AUTO | APEak | APLOCK | NONE | P0 | P6 | P12 | P18
```

E4406A

```
[ :SENSe ] :CDPower :ADC :RANGe
```

```
AUTO | APEak | APLOCK | M6 | P0 | P6 | P12 | P18 | P24
```

```
[ :SENSe ] :CDPower :ADC :RANGe?
```

Select a ranging function for the ADC gain control. This is an advanced control that normally does not need to be changed. If you are measuring a CW signal, see the following description:

- AUTO - automatic ranging

For FFT spectrums, the auto ranging should not be used. An exception to this would be if you know that your signal is “bursty”. Then you might use auto to maximize the time domain dynamic range as long as you are not very interested in the FFT data.

- APEak (Auto Peak) - automatic ranging to the peak signal level

For CW signals, the default of auto-peak ranging can be used, but a better FFT measurement of the signal can be made by selecting one of the manual ranges that is available by specifying M6, or P0 through P24.

SENSE Subsystem

Auto peaking can cause the ADC gain to monotonically track the ranges down during the data capture. This tracking effect should be negligible for the FFT spectrum, but selecting a manual range solves this possibility. Note that if the CW signal being measured is close to the auto-ranging threshold, the noise floor may shift as much as 6 dB every sweep.

- APLock (Auto Peak Lock) - automatic ranging locked to the peak signal level
For CW signals, auto-peak lock ranging may be used. It will find the ADC gain most appropriate for this particular signal and will not track the ranges as auto-peak can. Note that if the CW signal being measured is close to the auto-ranging threshold, the noise floor may shift as much as 6 dB every sweep.
For “bursty” signals, auto-peak lock ranging should not be used. Since the ADC range can often be locked to the wrong one resulting in overloading the ADC, the measurement will fail.
- NONE - (PSA) turns off any auto-ranging without making any changes to the current setting.
- M6 - (E4406A) manually selects an ADC range that subtracts 6 dB from the fixed gain across the range. Manual ranging is best for CW signals. This is the default selection for this measurement.
- P0 thru P24 - (E4406A) manually selects one of the ADC ranges that add 0 dB to 24 dB to the fixed gain across the range. Manual ranging is best for CW signals.
- P0 thru P18 - (PSA) manually selects one of the ADC ranges that add 0 dB to 24 dB to the fixed gain across the range. Manual ranging is best for CW signals.

Factory Preset: M6

Remarks: You must be in the 1xEV-DO mode to use this command. Use INSTRUMENT:SELEct to set the mode.

History: PSA:
Added in version A.02.00

E4406A:
Added in version A.05.00

Code Domain—Demod Alpha

```
[ :SENSE ]:CDPower:ALPHA <numeric>
```

```
[ :SENSE ]:CDPower:ALPHA?
```

Set alpha for the root Nyquist filter.

Factory Preset: 0.22

Range: 0.01 to 0.5

Remarks: You must be in the W-CDMA mode to use this command. Use INSTRUMENT:SELEct to set the mode.

Code Domain—Average Count

[:SENSe] :CDPower :AVERAge :COUNT <integer>

[:SENSe] :CDPower :AVERAge :COUNT?

Set the number of frames that will be averaged. After the specified number of frames (average counts) have been averaged, the averaging mode (termination control) setting determines the averaging action.

Factory Preset: 10

Range: 1 to 10,000

Remarks: You must be in the cdmaOne mode to use this command. Use INSTRUMENT:SELEct to set the mode.

Code Domain—Averaging State

[:SENSe] :CDPower :AVERAge [:STATe] OFF | ON | 0 | 1

[:SENSe] :CDPower :AVERAge [:STATe]?

Turn code domain power averaging on or off.

Factory Preset: ON

Remarks: You must be in the cdmaOne mode to use this command. Use INSTRUMENT:SELEct to set the mode.

Code Domain—Averaging Termination Control

[:SENSe] :CDPower :AVERAge :TCONtrol EXPOnential | REPeat

[:SENSe] :CDPower :AVERAge :TCONtrol?

Select the type of termination control used for averaging. This determines the averaging action after the specified number of frames (average count) is reached.

EXPOnential - Each successive data acquisition after the average count is reached, is exponentially weighted and combined with the existing average.

REPeat - After reaching the average count, the averaging is reset and a new average is started.

Factory Preset: REPeat

Remarks: You must be in the cdmaOne mode to use this command. Use INSTRUMENT:SELEct to set the mode.

SENSe Subsystem

Code Domain—Active Set Threshold

[:SENSe] :CDPower :ASET :THReshold <rel_power>

[:SENSe] :CDPower :ASET :THReshold?

Set the active set threshold value. Walsh channels with power less than this value, will be treated as non-active (noise) channels.

Factory Preset: -20 dB

Range: -30 dB to 0 dB

Default Unit: dB

Remarks: You must be in the cdmaOne mode to use this command. Use INSTRument:SElect to set the mode.

Code Domain—Data Capture Time

[:SENSe] :CDPower :CAPTure :TIME <numeric>

[:SENSe] :CDPower :CAPTure :TIME?

Set the data capture length in Power Control Groups (PCG; 1 PCG equals 1.25 ms) for cdma2000 and 1xEV-DO, or frames (1 frame equals 10 ms) for W-CDMA that will be used in the acquisition.

For cdma2000 Set the data capture length in Power Control Groups (PCG; 1 PCG equals 1.25 ms) that will be used in the acquisition.

For 1xEV-DO Set the data capture length in units of slots (1 slot equals 1.667 ms) that will be used in the acquisition.

For W-CDMA Set the data capture length in frames (1 frame equals 10 ms) for that will be used in the acquisition.

Factory Preset: 5 for cdma2000, 1xEV-DO
2.0 for W-CDMA

Range: 2 to 32 PCGs (2.5 to 40 ms) for cdma2000; 2 to 32 slots for 1xEV-DO
0.067 (any value below 1 is set to 0.067), 1.0, 2.0, 3.0, 4.0, and 8.0 frames (0.67 to 80 ms; 1/15 frame equals 1 slot) for W-CDMA. Other numeric values between 1 and 8 are rounded to the nearest integer; entries between integers are rounded up, excepting for entries above 8 which are rounded down to 8.

Remarks: You must be in the cdma2000, W-CDMA, or 1xEV-DO mode to use this command. Use INSTRument:SElect to set the mode.

Code Domain—Chip Rate

[:SENSe]:CDPower:CRATe <freq>

[:SENSe]:CDPower:CRATe?

Enter a frequency value to set the chip rate.

Factory Preset: 1.2288 MHz for cdma2000, 1xEV-DO
3.84 MHz for W-CDMA

Range: 1.10592 to 1.35168 MHz for cdma2000, 1xEV-DO
3.456 to 4.224 MHz for W-CDMA

Remarks: You must be in the cdma2000, W-CDMA, or 1xEV-DO mode to use this command. Use INSTRument:SElect to set the mode.

Code Domain—Method

[:SENSe]:CDPower:METHod FPOWER | POWER | TPHase

[:SENSe]:CDPower:METHod?

Select the measurement method.

- Fast Power (FPOWER)- Provides the fastest code domain power measurement. Only measures the power of those Walsh channels with powers greater than the active set threshold level.
- POWER - Measures the code domain power of all 64 Walsh Channels.
- Timing & Phase (TPHase)- Measures the code domain power, code domain timing, and code domain phase of all 64 Walsh channels.

Factory Preset: FPOWER

Remarks You must be in the cdmaOne mode to use this command. Use INSTRument:SElect to set the mode.

Code Domain—Phase Compensation by Pilot

[:SENSe]:CDPower:PILot:COMPensation[:STATE] OFF | ON | 0 | 1

[:SENSe]:CDPower:PILot:COMPensation[:STATE]?

Turn on or off the phase compensation (1 slot-based compensation)

Factory Preset: Off
On - Perform 1 slot-based phase compensation
Off - Do not perform 1 slot-based phase compensation

Remarks: You must be in the 1xEV-DO mode to use this command. Use INSTRument:SElect to set the mode.

SENSe Subsystem

Code Domain—PN Offset

[:SENSe] :CDPower :PNOffset <integer>

[:SENSe] :CDPower :PNOffset?

Set a PN sequence number for the base station being tested. This value behaves as a multiplier for the Walsh codes of which length is in the unit of 64 chips.

Factory Preset: 0

Range: 0 to 511

Unit: 64 chips

Remarks: You must be in the 1xEV-DO mode to use this command. Use INSTRument:SElect to set the mode.

History: PSA:
Added in version A.02.00
E4406A:
Added in version A.05.00

Code Domain—PRACH Preamble Signature

[:SENSe] :CDPower :PRACH :SIGNature <integer>

[:SENSe] :CDPower :PRACH :SIGNature?

Set Signature number for PRACH Preamble detection, when [:SENSe] :CDPower :PRACH :SIGNature :AUTO is set to OFF. This value is set at its auto number if PRACH Preamble Signature Auto mode is set to ON.

Factory Preset: 0

Range: 0 to 15

Remarks: You must be in the W-CDMA mode to use this command. Use INSTRument:SElect to set the mode.

Code Domain—PRACH Preamble Signature Detection

[:SENSe] :CDPower :PRACH :SIGNature :AUTO OFF | ON | 0 | 1

[:SENSe] :CDPower :PRACH :SIGNature :AUTO?

Set Signature Auto mode ON for PRACH Preamble detection.

Factory Preset: ON

Remarks: You must be in the W-CDMA mode to use this command. Use INSTRument:SElect to set the mode.

Code Domain—Preamble Length

```
[ :SENSE]:CDPower:PREamble:LENGth <integer>
```

```
[ :SENSE]:CDPower:PREamble:LENGth?
```

Set the Preamble length manually in chips.

Factory Preset: 0

Range: 0, 64, 128, 256, 512 and 1024

Remarks: You must be in the 1xEV-DO mode to use this command. Use INSTRUMENT:SELEct to set the mode.

Code Domain—Preamble Auto Detection

```
[ :SENSE]:CDPower:PREamble:LENGth:AUTO OFF|ON|0|1
```

```
[ :SENSE]:CDPower:PREamble:LENGth:AUTO?
```

Turn the Preamble Length detection mode on or off.

On - detects the Preamble length automatically.

Off - sets the Preamble length manually by
[:SENSE]:CDPower:PREamble:LENGth.

Factory Preset: ON

Remarks: You must be in the 1xEV-DO mode to use this command. Use INSTRUMENT:SELEct to set the mode.

Code Domain—Quasi-Orthogonal Function

```
[ :SENSE]:CDPower:QOF 0|1|2|3
```

```
[ :SENSE]:CDPower:QOF?
```

Set the Walsh code quasi-orthogonal function for expanding the number of downlink channels (subscribers).

Factory Preset: 0

Remarks: You must be in the cdma2000 mode to use this command. Use INSTRUMENT:SELEct to set the mode.

Code Domain—Symbol Boundary for BTS

```
[ :SENSE]:CDPower:SBOundary[ :BTS ]
```

```
AUTO|MAX|TM1D16|TM1D32|TM1D64|TM2|TM3D16|TM3D32|TM4|TM4CP|
```

SENSe Subsystem

TM1D16SC | TM1D32SC | TM1D64SC | TM2SC | TM3D16SC | TM3D32SC

[:SENSe] :CDPower :SBOundary?

Select the symbol boundary detection mode. This command is effective when the [:SENSe] :RADio :DEVice is set to BTS.

Auto - sets the symbol boundary detection to the automatic mode. Various code channels are measured and the most appropriate code channel is determined as the reference channel.

MAX - sets the symbol boundary detection to the maximum mode.

TM1D16 - sets the code domain power measurement to Test Model 1 with 16 DPCH channels.

TM1D32 - sets the code domain power measurement to Test Model 1 with 32 DPCH channels.

TM1D64 - sets the code domain power measurement to Test Model 1 with 64 DPCH channels.

TM2 - sets the code domain power measurement to Test Model 2.

TM3D16 - sets the code domain power measurement to Test Model 3 with 16 DPCH channels.

TM3D32 - sets the code domain power measurement to Test Model 3 with 32 DPCH channels.

TM4 - sets the symbol boundary detection to Test Model 4 w/o Primary CCPCH channel.

TM4CP - sets the symbol boundary detection to Test Model 4 with Primary CCPCH channel.

TM1D16SC -sets the symbol boundary detection to Test Model 1 with 16 DPCH channels including S-CCPCH [PCH].

TM1D32SC -sets the symbol boundary detection to Test Model 1 with 32 DPCH channels including S-CCPCH [PCH].

TM1D64SC -sets the symbol boundary detection to Test Model 1 with 64 DPCH channels including S-CCPCH [PCH].

TM2SC -sets the symbol boundary detection to Test Model 2 with S-CCPCH [PCH] channel.

TM3D16SC -sets the symbol boundary detection to Test Model 3 with 16 DPCH channels including S-CCPCH [PCH].

TM3D32SC -sets the symbol boundary detection to Test Model 3 with 32 DPCH channels including S-CCPCH [PCH].

Factory Preset: Auto

Remarks You must be in the W-CDMA mode to use this command. Use INSTRUMENT:SELEct to set the mode.

Code Domain—Slot Format for MS

[:SENSE] :CDPower :SFOFormat :MS SF0 | SF1 | SF2 | SF3 | SF4 | SF5

[:SENSE] :CDPower :SFOFormat :MS?

Set the slot format to define DPCCH pilot pattern to synchronize with, when the [:SENSE] :RADio :DEVIce is set to MS.

SF0 - slot format 0.

SF1 - slot format 1.

SF2 - slot format 2.

SF3 - slot format 3.

SF4 - slot format 4.

SF5 - slot format 5.

Factory Preset: SF0

Remarks: You must be in the W-CDMA mode to use this command. Use INSTRUMENT:SELEct to set the mode.

Code Domain—Spectrum Normal/Invert

[:SENSE] :CDPower :SPECTrum INVert | NORMAl

[:SENSE] :CDPower :SPECTrum?

Set a spectrum either to normal or inverted for the demodulation related measurements. If set to INVert, the upper and lower spectrums are swapped.

Factory Preset: NORMAl

Remarks You must be in the cdmaOne, cdma2000, W-CDMA, or 1xEV-DO mode to use this command. Use INSTRUMENT:SELEct to set the mode.

Code Domain—Measurement Interval

[:SENSE] :CDPower :SWEep :TIME <time>

[:SENSE] :CDPower :SWEep :TIME?

Set the length of the measurement interval that will be used.

Factory Preset: 1.250 ms

Range: 0.5 ms to 30 ms

SENSe Subsystem

Default Unit: seconds

Remarks: You must be in the cdmaOne mode to use this command. Use INSTRument:SElect to set the mode.

Code Domain—Sync Type (BTS)

[:SENSe] :CDPower :SYNC [:BTS] CPICH | SCH | SYMBol | A2CPich

[:SENSe] :CDPower :SYNC [:BTS] ?

Set the synchronization type for BTS.

CPICH - synchronize to common pilot channel (CPICH).

SCH - synchronize to synchronization channel (SCH).

Symbol - synchronize to the code symbol specified by the

[:SENSe] :CDPower :SYNC :SYMBol :SRATe and the

[:SENSe] :CDPower :SYNC :SYMBol :SPRead commands.

Factory Preset: CPICH

Remarks: You must be in the W-CDMA mode to use this command. Use INSTRument:SElect to set the mode.

Code Domain—Sync Type (MS)

[:SENSe] :CDPower :SYNC :MS DPCCh | PMESsage

[:SENSe] :CDPower :SYNC :MS ?

Select DPCCh or PMESsage for synchronization to uplink signal.

DPCCh - Synchronize to DPCCH and Slot Format which is specified by

[:SENSe] :CDPower :SFORmat :MS

PMESsage - Synchronize to PRACH Message and Slot Format which is

specified by [:SENSe] :CDPower :SFORmat :MS

Factory Preset: DPCCh

Remarks: You must be in the W-CDMA mode to use this command. Use INSTRument:SElect to set the mode. When the [:SENSe] :RADIo :DEVice is set to MS, dedicated physical control channel (DPCCH) is automatically set to the sync channel.

Code Domain—Long Code Mask

[:SENSe] :CDPower :SYNC :LCMask <integer>

[:SENSe] :CDPower :SYNC :LCMask ?

Set the long code mask for MS measurement.

Factory Preset: 2,199,023,255,552 (20,000,000,000h)

Range: 0 to 4,398,046,511,103 (0h to 3F,FFF,FFF,FFFh)

Remarks: You must be in the cdma2000 mode to use this command. Use INSTRument:SElect to set the mode.

Code Domain—Scramble Code Down Link

[:SENSe] :CDPower :SYNC :SCRamble [:BTS] <integer>

[:SENSe] :CDPower :SYNC :SCRamble [:BTS] ?

Set the BTS primary scramble code for synchronization.

Factory Preset: 0

Range: 0 to 511

Remarks: You must be in the W-CDMA mode to use this command. Use INSTRument:SElect to set the mode.

Code Domain—Scramble Code Offset

[:SENSe] :CDPower :SYNC :SCRamble [:BTS] :OFFSet <integer>

[:SENSe] :CDPower :SYNC :SCRamble [:BTS] :OFFSet ?

Set the BTS scramble code offset for synchronization.

Factory Preset: 0

Range: 0 to 15 (0 for the primary scramble code; 1 to 15 for the secondary scramble code)

Remarks: You must be in the W-CDMA mode to use this command. Use INSTRument:SElect to set the mode.

Code Domain—Sync Scramble Code Type Down Link

**[:SENSe] :CDPower :SYNC :SCRamble [:BTS] :TYPE
LEFT | RIGHT | STANDARD**

[:SENSe] :CDPower :SYNC :SCRamble [:BTS] :TYPE ?

Set the BTS primary scramble code type for synchronization.

LEFT – the left alternative scrambling code whose number is the primary scramble code number + 8192 is used.

RIGHT – the right alternative scrambling code whose number is the primary scrambling code number + 16384 is used.

SENSe Subsystem

STANdard – the standard scrambling code whose number is the primary scrambling code number is used.

Factory Preset: STANdard

Remarks: You must be in the W-CDMA mode to use this command. Use INSTRument:SElect to set the mode.

Code Domain—Scramble Code Up Link

[:SENSe] :CDPower :SYNC :SCRamble :MS <integer>

[:SENSe] :CDPower :SYNC :SCRamble :MS?

Set the MS scramble code for synchronization.

Factory Preset: 0

Range: 0 to 16,777,215 (0h to FFF,FFFh)

Remarks: You must be in the W-CDMA mode to use this command. Use INSTRument:SElect to set the mode.

Code Domain—Synchronization Symbol Spread Code

[:SENSe] :CDPower :SYNC :SYMBOL :SPRead <integer>

[:SENSe] :CDPower :SYNC :SYMBOL :SPRead?

Set the spread code of the code symbol to synchronize with. This command is effective when the [:SENSe] :CDPower :SYNC command is set to SYMBOL.

Factory Preset: 1

Range: 0 to 511, when [:SENSe] :CDPower :SYNC :SYMBOL :SRATe = 7500

0 to 255, when [:SENSe] :CDPower :SYNC :SYMBOL :SRATe = 15000

0 to 127, when [:SENSe] :CDPower :SYNC :SYMBOL :SRATe = 30000

0 to 63, when [:SENSe] :CDPower :SYNC :SYMBOL :SRATe = 60000

0 to 31, when [:SENSe] :CDPower :SYNC :SYMBOL :SRATe = 120000

0 to 15, when [:SENSe] :CDPower :SYNC :SYMBOL :SRATe = 240000

0 to 7, when [:SENSe] :CDPower :SYNC :SYMBOL :SRATe = 480000

0 to 3, when [:SENSE]:CDPower:SYNC:SYMBOL:SRATE = 960000

Remarks: You must be in the W-CDMA mode to use this command. Use INSTRUMENT:SELEct to set the mode.

Code Domain—Synchronization Symbol Rate

[:SENSE]:CDPower:SYNC:SYMBOL:SRATE <integer>

[:SENSE]:CDPower:SYNC:SYMBOL:SRATE?

Set the symbol rate of the code symbol to synchronize with. This command is effective when the [:SENSE]:CDPower:SYNC command is set to SYMBOL.

Factory Preset: 7500

Range: 7500, 15000, 30000, 60000, 120000, 240000, 480000, 960000

Remarks: You must be in the W-CDMA mode to use this command. Use INSTRUMENT:SELEct to set the mode.

Code Domain—Trigger Source

[:SENSE]:CDPower:TRIGGER:SOURCE

EXTERNAL[1] | EXTERNAL2 | FRAME | IF | IMMEDIATE | RFBURST

[:SENSE]:CDPower:TRIGGER:SOURCE?

Select one of the trigger sources used to control the data acquisitions.

EXTERNAL 1 – front panel external trigger input

EXTERNAL 2 – rear panel external trigger input

FRAME – internal frame trigger

IF – internal IF envelope (video) trigger

IMMEDIATE – the next data acquisition is immediately taken, capturing the signal asynchronously (also called free run).

RFBURST – internal wideband RF burst envelope trigger that has automatic level control for periodic burst signals.

Factory Preset: IMMEDIATE

Remarks: You must be in the cdma2000, W-CDMA, or 1xEV-DO mode to use this command. Use INSTRUMENT:SELEct to set the mode.

Front Panel

Access: **Meas Setup, Trig Source**

Channel Commands

Select the ARFCN—Absolute RF Channel Number

[:SENSe] :CHANnel :ARFCn | RFCHannel <integer>

[:SENSe] :CHANnel :ARFCn | RFCHannel ?

Set the analyzer to a frequency that corresponds to the ARFCN (Absolute RF Channel Number).

Factory Preset: 38

Range: 0 to 124, and 975 to 1023 for E-GSM

1 to 124 for P-GSM

0 to 124, and 955 to 1023 for R-GSM

512 to 885 for DCS1800

512 to 810 for PCS1900

259 to 293 for GSM450

306 to 340 for GSM480

438 to 511 for GSM700

128 to 251 for GSM850

Remarks: You must be in the GSM, EDGE mode to use this command.
Use INSTRument:SELEct to set the mode.

Global to the current mode.

History: E4406A:
Version A.03.00 or later

Front Panel

Access: **FREQUENCY Channel, ARFCN**

Select the Lowest ARFCN

[:SENSe] :CHANnel :ARFCn | RFCHannel :BOTTom

Set the analyzer to the frequency of the lowest ARFCN (Absolute RF Channel Number) of the selected radio band.

Factory Preset: 975 for E-GSM

1 for P-GSM

955 for R-GSM

512 for DCS1800

512 PCS1900

259 GSM450

306 GSM480

438 GSM700

128 GSM850

Remarks: You must be in the GSM, EDGE mode to use this command.
Use INSTRument:SElect to set the mode.

Global to the current mode.

History: E4406A:
Version A.03.00 or later

Front Panel

Access: **FREQUENCY Channel, BMT Freq****Select the Middle ARFCN****[:SENSe] :CHANnel :ARFCn | RFChannel :MIDDLE**

Set the analyzer to the frequency of the middle ARFCN (Absolute RF Channel Number) of the selected radio band.

Factory Preset: 38 for E-GSM
63 for P-GSM
28 for R-GSM
699 for DCS1800
661 for PCS1900
276 for GSM450
323 for GSM480
474 for GSM 700
189 for GSM850

Remarks: You must be in the GSM, EDGE mode to use this command.
Use INSTRument:SElect to set the mode.

Global to the current mode.

History: E4406A:
Version A.03.00 or later

Front Panel

Access: **FREQUENCY Channel, BMT Freq**

SENSe Subsystem

Select the Highest ARFCN

[:SENSe] :CHANnel :ARFCn | RFChannel :TOP

Set the analyzer to the frequency of the highest ARFCN (Absolute RF Channel Number) of the selected radio band.

Factory Preset: 124 for E-GSM
124 for P-GSM
124 for R-GSM
885 for DCS1800
810 for PCS1900
293 for GSM450
340 for GSM480
511 for GSM700
251 for GSM850

Remarks: You must be in the GSM, EDGE mode to use this command.
Use INSTRument:SElect to set the mode.
Global to the current mode.

History: E4406A:
Version A.03.00 or later

Front Panel
Access: **FREQUENCY Channel, BMT Freq**

Burst Type

[:SENSe] :CHANnel :BURSt TCH | CCH

[:SENSe] :CHANnel :BURSt ?

Set the burst type for mobile station testing.

Traffic Channel (TCH) – burst for traffic channel

Control Channel (CCH) – burst for control channel

Factory Preset: TCH

Remarks: The command is only applicable for mobile station testing,
device = MS.

You must be in the NADC or PDC mode to use this command.
Use INSTRument:SElect to set the mode.

Channel Burst Type

```
[ :SENSe ]:CHANnel:BURSt NORMAl | SYNC | ACCess
```

```
[ :SENSe ]:CHANnel:BURSt?
```

Set the burst type that the analyzer will search for and to which it will sync. This only applies with normal burst selected.

NORMAl: Traffic Channel (TCH) and Control Channel (CCH)

SYNC: Synchronization Channel (SCH)

ACCess: Random Access Channel (RACH)

Remarks: You must be in the GSM, EDGE mode to use this command.
Use INSTRument:SElect to set the mode.

Global to the current mode.

Front Panel

Access: **FREQUENCY Channel, Burst Type**

Digital Demod PN Offset

```
[ :SENSe ]:CHANnel:PNOFFset <integer>
```

```
[ :SENSe ]:CHANnel:PNOFFset?
```

Set the PN offset number for the base station being tested.

Factory Preset: 0

Range: 0 to 511

Default Unit: None

Remarks: Global to the current mode.

You must be in the cdmaOne mode to use this command. Use INSTRument:SElect to set the mode.

Front Panel

Access: **FREQUENCY Channel, PN Offset**

or

Mode Setup, Demod, PN Offset

Time Slot number

```
[ :SENSe ]:CHANnel:SLOT <integer>
```

```
[ :SENSe ]:CHANnel:SLOT?
```

Select the slot number that you want to measure.

SENSE Subsystem

In GSM mode the measurement frame is divided into the eight expected measurement timeslots.

Factory Preset: 0 for GSM, EDGE, PDC mode
1 for NADC mode

Range: 0 to 5 for PDC mode
1 to 6 for NADC mode
0 to 7 for GSM, EDGE mode

Remarks: You must be in GSM, EDGE, NADC, or PDC mode to use this command. Use INSTRument:SElect to set the mode.

Front Panel

Access: **Mode Setup, Radio, Frequency Hopping Repetition Factor**

Time Slot Auto

```
[ :SENSE ] :CHANnel :SLOT :AUTO OFF | ON | 0 | 1
```

```
[ :SENSE ] :CHANnel :SLOT :AUTO?
```

Select auto or manual control for slot searching. The feature is only supported in external and frame trigger source modes. In external trigger mode when timeslot is set on, the demodulation measurement is made on the nth timeslot specified by the external trigger point + n timeslots, where n is the selected timeslot value 0 to 7. In frame trigger mode when timeslot is set on, then demodulation measurement is only made on the nth timeslot specified by bit 0 of frame reference burst + n timeslots, where n is the selected timeslot value 0 to 7 and where the frame reference burst is specified by Ref Burst and Ref TSC (Std) combination.

Factory Preset: ON, for NADC, PDC mode
OFF, for GSM, EDGE mode

Remarks: The command is only applicable for mobile station testing, device = MS.

You must be in GSM, EDGE, NADC, or PDC mode to use this command. Use INSTRument:SElect to set the mode.

History: E4406A:
Added GSM mode, version A.03.00 or later

Training Sequence Code (TSC)

```
[ :SENSE ] :CHANnel :TSCode <integer>
```

```
[ :SENSE ] :CHANnel :TSCode?
```

Set the training sequence code to search for, with normal burst selected and TSC

auto set to off.

Factory Preset: 0

Range: 0 to 7

Remarks: Global to the current mode.

You must be in the GSM, EDGE mode to use this command.
Use INSTRUMENT:SElect to set the mode.

History: E4406A:
Version A.03.00 or later

Front Panel

Access: **FREQUENCY Channel, TSC (Std)**

Training Sequence Code (TSC) Auto

[:SENSE] : CHANNEL : TSCode : AUTO OFF | ON | 0 | 1

[:SENSE] : CHANNEL : TSCode : AUTO?

Select auto or manual control for training sequence code (TSC) search. With auto on, the measurement is made on the first burst found to have one of the valid TSCs in the range 0 to 7 (i.e. normal bursts only). With auto off, the measurement is made on the 1st burst found to have the selected TSC.

Factory Preset: AUTO

Remarks: Global to the current mode.

You must be in the GSM, EDGE mode to use this command.
Use INSTRUMENT:SElect to set the mode.

Front Panel

Access: **FREQUENCY Channel, TSC (Std)**

Channel Power Measurement

Commands for querying the channel power measurement results and for setting to the default values are found in the “MEASure Group of Commands” on page 193. The equivalent front panel keys for the parameters described in the following commands, are found under the **Meas Setup** key, after the **Channel Power** measurement has been selected from the **MEASURE** key menu.

Channel Power—Average Count

```
[ :SENSe ] :CHPower :AVERAge :COUNT <integer>
```

```
[ :SENSe ] :CHPower :AVERAge :COUNT?
```

Set the number of data acquisitions that will be averaged. After the specified number of average counts, the averaging mode (terminal control) setting determines the averaging action.

Factory Preset: 20
200, for W-CDMA

Range: 1 to 10,000

Remarks: For E4406A you must be in the Basic, cdmaOne, cdma2000, W-CDMA, or 1xEV-DO mode to use this command. Use INSTRument:SElect to set the mode.

Channel Power—Averaging State

```
[ :SENSe ] :CHPower :AVERAge [ :STATe ] OFF | ON | 0 | 1
```

```
[ :SENSe ] :CHPower :AVERAge [ :STATe ]?
```

Turn averaging on or off.

Factory Preset: ON

Remarks: For E4406A you must be in the Basic, cdmaOne, cdma2000, W-CDMA, or 1xEV-DO mode to use this command. Use INSTRument:SElect to set the mode.

Channel Power—Averaging Termination Control

```
[ :SENSe ] :CHPower :AVERAge :TCONTRol EXPonential | REPeat
```

```
[ :SENSe ] :CHPower :AVERAge :TCONTRol?
```

Select the type of termination control used for the averaging function. This determines the averaging action after the specified number of data acquisitions (average count) is reached.

EXPonential - Each successive data acquisition after the average count is reached, is exponentially weighted and combined with the existing average.

REPeat - After reaching the average count, the averaging is reset and a new average is started.

Factory Preset: REPeat

Remarks: For E4406A you must be in the Basic, cdmaOne, cdma2000, W-CDMA, or 1xEV-DO mode to use this command. Use INSTRument:SELEct to set the mode.

Channel Power—Integration BW

[:SENSe]:CHPower:BANDwidth|BWIDth:INTEgration <freq>

[:SENSe]:CHPower:BANDwidth|BWIDth:INTEgration?

Set the Integration BW (IBW) that will be used.

Factory Preset: 1.23 MHz for Basic (E4406A), cdmaOne, cdma2000, 1xEV-DO
5.0 MHz for W-CDMA

Range: 1 kHz to 10 MHz

Default Unit: Hz

Remarks: For E4406A you must be in the Basic, cdmaOne, cdma2000, W-CDMA, or 1xEV-DO mode to use this command. Use INSTRument:SELEct to set the mode.

Channel Power—Span

[:SENSe]:CHPower:FREQuency:SPAN <freq>

[:SENSe]:CHPower:FREQuency:SPAN?

Set the frequency span that will be used.

Factory Preset: 2.0 MHz for Basic, cdmaOne, cdma2000, 1xEV-DO
6.0 MHz for W-CDMA

Range: Dependent on the current setting of the channel power integration bandwidth

Default Unit: Hz

Remarks: For E4406A you must be in the Basic, cdmaOne, cdma2000, W-CDMA, or 1xEV-DO mode to use this command. Use INSTRument:SELEct to set the mode.

Channel Power—Data Points

[:SENSe]:CHPower:POINts <integer>

SENSe Subsystem

[:SENSe] :CHPower :POINTs?

Set the number of data points that will be used. Changing this will change the time record length and resolution BW that are used.

Factory Preset: 512

Range: 64 to 32768, in a 2ⁿ sequence

Remarks: For PSA you must be in the cdmaOne, cdma2000, W-CDMA, or 1xEV-DO mode to use this command. Use INSTRument:SElect to set the mode.

For E4406A you must be in the Basic, cdmaOne, cdma2000, W-CDMA, or 1xEV-DO mode to use this command. Use INSTRument:SElect to set the mode.

Channel Power—Data Points Auto

[:SENSe] :CHPower :POINTs :AUTO OFF | ON | 0 | 1

[:SENSe] :CHPower :POINTs :AUTO?

Select auto or manual control of the data points. This is an advanced control that normally does not need to be changed. Setting this to a value other than the factory default, may cause invalid measurement results.

OFF - the Data Points is uncoupled from the Integration BW.

ON - couples the Data Points to the Integration BW.

Factory Preset: ON

Remarks: You must be in the Basic (E4406A), cdmaOne, cdma2000, W-CDMA, 1xEV-DO mode to use this command. Use INSTRument:SElect to set the mode.

Channel Power—Sweep Time

[:SENSe] :CHPower :SWEep :TIME <time>

[:SENSe] :CHPower :SWEep :TIME?

Sets the sweep time when using the sweep mode.

Factory Preset: 68.27 μ s

17.07 μ s for W-CDMA

Range: 1 μ s to 50 ms

Default Unit: seconds

Remarks: You must be in the Basic (E4406A), cdmaOne, cdma2000, W-CDMA, or 1xEV-DO mode to use this command. Use

INSTRument:SElect to set the mode.

History: E4406A:
Version A.03.00 and later

Channel Power—Sweep Time

[:SENSE] :CHPower :SWEep :TIME :AUTO OFF | ON | 0 | 1

[:SENSE] :CHPower :SWEep :TIME :AUTO?

Selects the automatic sweep time, optimizing the measurement.

Factory Preset: ON

Remarks: You must be in the Basic (E4406A), cdmaOne, cdma2000, W-CDMA, or 1xEV-DO mode to use this command. Use INSTRument:SElect to set the mode.

History: E4406A:
Version A.03.00 and later

Channel Power—Trigger Source

[:SENSE] :CHPower :TRIGger :SOURce
EXTernal [1] | EXTernal 2 | IMMEDIATE

[:SENSE] :CHPower :TRIGger :SOURce?

Select the trigger source used to control the data acquisitions. This is an Advanced control that normally does not need to be changed.

EXTernal 1 - front panel external trigger input

EXTernal 2 - rear panel external trigger input

IMMEDIATE - the next data acquisition is immediately taken (also called Free Run).

Factory Preset: IMMEDIATE

Remarks: For E4406A you must be in the Basic, cdmaOne, cdma2000, W-CDMA, or 1xEV-DO mode to use this command. Use INSTRument:SElect to set the mode.

Signal Corrections Commands

Correction for Base Station RF Port External Attenuation

`[:SENSe] :CORRection:BS[:RF]:LOSS <rel_power>`

`[:SENSe] :CORRection:BS[:RF]:LOSS?`

Set the correction equal to the external attenuation used when measuring base stations.

Factory Preset: 0 dB

Range: -50 to 100 dB for cdmaOne, iDEN (E4406A)
-50 to 50 dB for NADC or PDC

Default Unit: dB

Remarks: You must be in the iDEN (E4406A), cdmaOne, NADC or PDC mode to use this command. Use INSTRUMENT:SELEct to set the mode.

Value is global to the current mode.

Correction for BTS RF Port External Attenuation

`[:SENSe] :CORRection:BTS[:RF]:LOSS <rel_power>`

`[:SENSe] :CORRection:BTS[:RF]:LOSS?`

Set equal to the external attenuation used when measuring base transmission stations.

Factory Preset: 0.0 dB

Range: -50 to 100.0 dB for GSM, EDGE
-100.0 to 100.0 dB for cdma2000, W-CDMA, 1xEV-DO

Default Unit: dB

Remarks: Global to the current mode.

You must be in the GSM, EDGE, cdma2000, W-CDMA, or 1xEV-DO mode to use this command. Use INSTRUMENT:SELEct to set the mode.

Correction for MS RF Port External Attenuation

`[:SENSe] :CORRection:MS[:RF]:LOSS <rel_power>`

`[:SENSe] :CORRection:MS[:RF]:LOSS?`

Set the correction equal to the external attenuation used when measuring mobile stations.

Factory Preset: 0.0 dB

Range: -50 to 100.0 dB for cdmaOne, GSM, EDGE, iDEN
 -100.0 to 100.0 dB for cdma2000, W-CDMA, 1xEV-DO
 -50.0 to 50.0 dB for NADC, PDC

Default Unit: dB

Remarks: For E4406A you must be in the cdmaOne, GSM, EDGE (w/GSM), cdma2000, W-CDMA, iDEN, NADC, PDC, or 1xEV-DO mode to use this command. Use INSTRument:SElect to set the mode.

For PSA you must be in the cdmaOne, GSM (w/EDGE), cdma2000, W-CDMA, NADC, PDC, or 1xEV-DO mode to use this command. Use INSTRument:SElect to set the mode.

Value is global to the current mode.

Correction for RF Port External Attenuation

```
[ :SENSe]:CORRection[ :RF]:LOSS <rel_power>
```

```
[ :SENSe]:CORRection[ :RF]:LOSS?
```

Set the correction equal to the external attenuation used when measuring the device under test.

Factory Preset: 0 dB

Range: -50 to +50 dB

Default Unit: dB

Remarks: You must be in the Basic mode to use this command. Use INSTRument:SElect to set the mode.

Value is global to Basic mode.

Front Panel
 Access: **Input, Ext Atten**

Spur Close—Measurement

Commands for querying the close spurs measurement results and for setting to the default values are found in the “MEASure Group of Commands” on page 193. The equivalent front panel keys for the parameters described in the following commands, are found under the **Meas Setup** key, after the **Spur Close** measurement has been selected from the **MEASURE** key menu.

Spur Close—Average Count

[:SENSe] :CSPur :AVERAge :COUNT <integer>

[:SENSe] :CSPur :AVERAge :COUNT?

Set the number of data acquisitions that will be averaged. After the specified number of average counts, the averaging mode (terminal control) setting determines the averaging action.

Factory Preset: 15

Range: 1 to 10,000

Remarks: You must be in the cdmaOne mode to use this command. Use INSTRument:SElect to set the mode.

Front Panel

Access: **Meas Setup**

Spur Close—Averaging State

[:SENSe] :CSPur :AVERAge [:STATe] OFF | ON | 0 | 1

[:SENSe] :CSPur :AVERAge [:STATe]?

Turn averaging on or off.

Factory Preset: ON

Remarks: You must be in the cdmaOne mode to use this command. Use INSTRument:SElect to set the mode.

Front Panel

Access: **Meas Setup**

Spur Close—Averaging Termination Control

[:SENSe] :CSPur :AVERAge :TCONTRol EXPOnential | REPeat

[:SENSe] :CSPur :AVERAge :TCONTRol?

Select the type of termination control used for the averaging function. This determines the averaging action after the specified number of data acquisitions (average count) is reached.

EXponential - Each successive data acquisition after the average count is reached, is exponentially weighted and combined with the existing average.

REPeat - After reaching the average count, the averaging is reset and a new average is started.

Factory Preset: REPeat

Remarks: You must be in the cdmaOne mode to use this command. Use INSTRUMENT:SElect to set the mode.

Front Panel

Access: Meas Setup

Spur Close—Averaging Type

[:SENSe] : CSPur : AVERAge : TYPE LOG | MAXimum | RMS | SCALar

[:SENSe] : CSPur : AVERAge : TYPE?

Select the type of averaging.

LOG - The log of the power is averaged. (This is also known as video averaging.)

MAXimum - The maximum values are retained.

RMS - The power is averaged, providing the rms of the voltage.

SCALar - The voltage is averaged.

Factory Preset: RMS

Remarks: You must be in the cdmaOne mode to use this command. Use INSTRUMENT:SElect to set the mode.

Spur Close—Type

[:SENSe] : CSPur : TYPE EXAMine | FULL

[:SENSe] : CSPur : TYPE?

Select the measurement type.

EXAMine - measures spurs in the upper, lower, and center segments and then displays the worst spur

FULL - continuously measures the spurs in the upper, lower, and center segments

Factory Preset: FULL

Remarks: You must be in the cdmaOne mode to use this command. Use INSTRUMENT:SElect to set the mode.

Front Panel

SENSe Subsystem

Access: **Meas Setup, Advanced (E4406A)**

EDGE Error Vector Magnitude Measurement

Commands for querying the EDGE error vector magnitude measurement results and for setting to the default values are found in the “[MEASure Group of Commands](#)” on page 193. The equivalent front panel keys for the parameters described in the following commands, are found under the **Meas Setup** key, after the measurement has been selected from the **MEASURE** key menu.

History: For E4406A: the EEVM measurement was added in version A.04.00.

EDGE Error Vector Magnitude—Average Count

[:SENSe] :EEVM:AVERAge:COUNT <integer>

[:SENSe] :EEVM:AVERAge:COUNT?

Sets the number of data acquisitions that will be averaged. After the specified number of average counts, the average mode (termination control) setting determines the average action.

Factory Preset: 10

Range: 1 to 10,000

Remarks: You must be in the EDGE(w/GSM) mode to use this command. Use INSTRument:SElect to set the mode.

History: Added version A.04.00 and later

EDGE Error Vector Magnitude—Averaging State

[:SENSe] :EEVM:AVERAge[:STATe] OFF | ON | 0 | 1

[:SENSe] :EEVM:AVERAge[:STATe]?

Turn average on or off.

Factory Preset: ON

Remarks: You must be in the EDGE(w/GSM) mode to use this command. Use INSTRument:SElect to set the mode.

History: For E4406A: Added version A.04.00

EDGE Error Vector Magnitude—Averaging Termination Control

[:SENSe] :EEVM:AVERAge:TCONtrol EXPonential | REPeat

[:SENSe] :EEVM:AVERAge:TCONtrol?

Select the type of termination control used to averaging. This determines the averaging action after the specified number of data acquisitions (average count) is

SENSE Subsystem

reached.

EXponential – Each successive data acquisition after the average count is reached, is exponentially weighted and combined with the existing average.

REPeat – After reaching the average count, the averaging is reset and a new average is started.

Factory Preset: EXPOnential

Remarks: You must be in the EDGE(w/GSM) mode to use this command.
Use INSTRument:SELEct to set the mode.

History: For E4406A: Added version A.04.00

EDGE Error Vector Magnitude—Burst Synchronization Source

[:SENSE] :EEVM:BSYNc:SOURce RFBurst | TSEQUence | NONE

[:SENSE] :EEVM:BSYNc:SOURce?

Select the method of synchronizing the measurement to the bursts.

RFBurst – The burst synchronization approximates the start and stop of the useful part of the burst without demodulation of the burst. This type of synchronization has a frequency lock range of up to 9 kHz and allows you to demodulate RF bursts that do not have a training sequence.

Training Sequence (TSEQUence) – The burst synchronization performs a demodulation of the burst and determines the start and stop of the useful part of the burst based on the midamble training sync sequence. This type of synchronization provides better noise immunity but has a smaller frequency lock range (~200 Hz).

None – The measurement is performed without searching burst.

Factory Preset: TSEQUence

Remarks: You must be in the EDGE(w/GSM) mode to use this command.
Use INSTRument:SELEct to set the mode.

History: For E4406A: Added version A.04.00

EDGE Error Vector Magnitude—Droop Compensation

[:SENSE] :EEVM:DROOp OFF | ON | 0 | 1

[:SENSE] :EEVM:DROOp?

Turn droop compensation on or off. Droop compensation corrects amplitude variations across a burst. You may want to turn off this compensation so you can see the changes in the measured magnitude error. Droop can result from signal impairments such as a power amplifier problem.

Factory Preset: ON
 Range: OFF, ON
 Remarks: You must be in the EDGE(w/GSM) mode to use this command.
 Use INSTRument:SElect to set the mode.
 History: For E4406A: Added version A.04.00

EDGE Error Vector Magnitude—Activate Extreme Limits

[:SENSe]:EEVM:ELIMit OFF|ON|0|1

[:SENSe]:EEVM:ELIMit?

Turn EEVM extreme limits on or off. GSM 5.05 provides two sets of limits, called “Normal” and “Extreme”. Select “ON” to turn the extreme limits on. Select “OFF” to return limits to the “Normal” parameter after the “Extreme” limits have been selected.

Factory Preset: OFF
 Range: OFF, ON
 Remarks: You must be in the EDGE(w/GSM) mode to use this command.
 Use INSTRument:SElect to set the mode.
 History: For E4406A: Added version A.04.00

EDGE Error Vector Magnitude—Points/Symbol

[:SENSe]:EEVM:SDOTs OFF|ON|0|1

[:SENSe]:EEVM:SDOTs?

Activates or deactivates points/symbol dot display.

Factory Preset: ON
 Range: OFF, ON
 Remarks: You must be in the EDGE(w/GSM) mode to use this command.
 Use INSTRument:SElect to set the mode.
 History: For E4406A: Added version A.04.00

EDGE Error Vector Magnitude—Points/Symbol

[:SENSe]:EEVM:TRACe:SDOTs <integer>

[:SENSe]:EEVM:TRACe:SDOTs?

Selects the number of dots that will be displayed for each symbol.

SENSe Subsystem

Factory Preset: 5
Range: 1 to 5
Remarks: You must be in the EDGE(w/GSM) mode to use this command.
Use INSTRument:SElect to set the mode.
History: For E4406A: Added version A.04.00

EDGE Error Vector Magnitude—Trigger Source

```
[ :SENSe ] :EEVM:TRIGger:SOURce  
EXTernal[1] | EXTernal2 | FRAME | IF | IMMEDIATE | RFBurst
```

```
[ :SENSe ] :EEVM:TRIGger:SOURce?
```

Select the trigger source used to control the data acquisitions.

EXTernal 1 – front panel external trigger input

EXTernal 2 – rear panel external trigger input

IF – internal IF envelope (video) trigger

IMMEDIATE – the next data acquisition is immediately taken, capturing the signal asynchronously (also called free run)

FRAME – internal frame trigger from front panel input

RFBurst – wideband RF burst envelope trigger that has automatic level control for periodic burst signals

Factory Preset: IMMEDIATE for BS
RFBurst for MS
Remarks: You must be in the EDGE(w/GSM) mode to use this command.
Use INSTRument:SElect to set the mode.
History: For E4406A: Added version A.04.00

EDGE Output RF Spectrum Measurement

Commands for querying the EDGE output RF spectrum measurement results and for setting to the default values are found in the “MEASure Group of Commands” on page 193. The equivalent front panel keys for the parameters described in the following commands, are found under the **Meas Setup** key, after the **EDGE Output RF Spectrum** measurement has been selected from the **MEASURE** key menu.

History: For E4406A: the EORF measurement was added in version A.04.00.

EDGE Output RF Spectrum—Number of Bursts Averaged

```
[ :SENSe ]:EORFspectr:AVERAge:COUnT <integer>
```

```
[ :SENSe ]:EORFspectr:AVERAge:COUnT?
```

Set the number of bursts that will be averaged. For the output RF spectrum due to switching transients, it is more accurate to consider this the number of frames that are measured. After the specified number of bursts (average counts), the averaging mode (terminal control) setting determines the averaging action.

Factory Preset: 20

Range: 1 to 10,000

Remarks: You must be in the EDGE(w/GSM) mode to use this command. Use INSTRument:SElect to set the mode.

EDGE Output RF Spectrum—Fast Averaging

```
[ :SENSe ]:EORFspectr:AVERAge:FAST[ :STATe ] OFF|ON|0|1
```

```
[ :SENSe ]:EORFspectr:AVERAge:FAST[ :STATe ]?
```

Make the measurement faster by using an averaging technique different from that defined by the standard. A valid average can be obtained by measuring the power in half the normal number of bursts by using 50% - 90% of the burst, 10% - 50% of the burst and excluding the midamble.

This faster averaging is only done when averaging is on and only the modulation results are being measured. If both modulation and switching transients results are being measured, then the measurement uses the default averaging.

Factory Preset: ON

Remarks: You must be in the EDGE(w/GSM) mode to use this command. Use INSTRument:SElect to set the mode.

SENSe Subsystem

EDGE Output RF Spectrum—Averaging Type for Modulation Spectrum

```
[ :SENSe ] :EORFspectr :AVERAge :MODulation :TYPE LOG | RMS
```

```
[ :SENSe ] :EORFspectr :AVERAge :MODulation :TYPE?
```

Select the type of averaging for measuring the modulation spectrum. This is an advanced control that normally does not need to be changed. Setting this to a value other than the factory default, may cause invalid measurement results.

LOG - The log of the power is averaged. (This is also known as video averaging.)

RMS - The power is averaged, providing the rms of the voltage.

Factory Preset: LOG

Remarks: You must be in the EDGE(w/GSM) mode to use this command.
Use INSTRument:SELEct to set the mode.

History: For E4406A: Added in version A.04.00

EDGE Output RF Spectrum—Averaging Control

```
[ :SENSe ] :EORFspectr :AVERAge [ :STATE ] OFF | ON | 0 | 1
```

```
[ :SENSe ] :EORFspectr :AVERAge [ :STATE ]?
```

Turn averaging on or off.

Factory Preset: ON

Remarks: You must be in the EDGE(w/GSM) mode to use this command.
Use INSTRument:SELEct to set the mode.

EDGE Output RF Spectrum—Resolution BW for the Modulation Spectrum at the Carrier

```
[ :SENSe ] :EORFspectr :BANDwidth | BWIDth [ :RESolution ]  
:MODulation :CARRier <freq>
```

```
[ :SENSe ] :EORFspectr :BANDwidth | BWIDth [ :RESolution ]  
:MODulation :CARRier?
```

Selects the resolution bandwidth for measuring the carrier when measuring spectrum due to modulation and wideband noise.

This parameter is only used with the Standard or Short lists, and not with the Custom list.

Factory Preset: 30 kHz

Range: 1 kHz to 5 MHz

Default Unit: Hz

Remarks: You must be in the EDGE(w/GSM) mode to use this command.
Use INSTRument:SElect to set the mode.

EDGE Output RF Spectrum—Resolution BW For Modulation At Close Offsets

```
[ :SENSe ]:EORFspectr:BANDwidth|BWIDth[:RESolution]
:MODulation:OFFSet:CLOSe <freq>
```

```
[ :SENSe ]:EORFspectr:BANDwidth|BWIDth[:RESolution]
:MODulation:OFFSet:CLOSe?
```

Set the resolution bandwidth used for the spectrum due to modulation part of the EORF measurement for offset frequencies less than 1800 kHz.

This parameter is only used with the Standard or Short lists, and not with the Custom list.

Factory Preset: 30 kHz

Range: 1 kHz to 5 MHz

Default Unit: Hz

Remarks: You must be in the EDGE(w/GSM) mode to use this command.
Use INSTRument:SElect to set the mode.

EDGE Output RF Spectrum—Resolution BW for Modulation at Far Offsets

```
[ :SENSe ]:EORFspectr:BANDwidth|BWIDth[:RESolution]
:MODulation:OFFSet:FAR <freq>
```

```
[ :SENSe ]:EORFspectr:BANDwidth|BWIDth[:RESolution]
:MODulation:OFFSet:FAR?
```

Set the resolution bandwidth used for the spectrum due to modulation part of the EORF measurement for offset frequencies greater than or equal to 1800 kHz.

This parameter is only used with the Standard or Short lists, and not with the Custom list.

Factory Preset: 100 kHz

Range: 1 kHz to 5 MHz

Default Unit: Hz

Remarks: You must be in the EDGE(w/GSM) mode to use this command.
Use INSTRument:SElect to set the mode.

SENSe Subsystem

EDGE Output RF Spectrum—Resolution BW for the Switching Transient Spectrum at the Carrier

```
[ :SENSe ] :EORFspectr :BANDwidth | BWIDth [ :RESolution ]  
:SWITching :CARRier <freq>
```

```
[ :SENSe ] :EORFspectr :BANDwidth | BWIDth [ :RESolution ]  
:SWITching :CARRier?
```

Selects the resolution bandwidth for the carrier when measuring spectrum due to switching transients.

This parameter is only used with the Standard or Short lists, and not with the Custom list.

Factory Preset: 300 kHz

Range: 1 kHz to 5 MHz

Default Unit: Hz

Remarks: You must be in the EDGE(w/GSM) mode to use this command.
Use INSTRument:SElect to set the mode.

EDGE Output RF Spectrum—Resolution BW For Switching Transients At Close Offsets

```
[ :SENSe ] :EORFspectr :BANDwidth | BWIDth [ :RESolution ]  
:SWITching :OFFSet :CLOSe <freq>
```

```
[ :SENSe ] :EORFspectr :BANDwidth | BWIDth [ :RESolution ]  
:SWITching :OFFSet :CLOSe?
```

Set the resolution bandwidth used for the spectrum due to switching transients part of the EORF measurement for offset frequencies less than 1800 kHz.

This parameter is only used with the Standard or Short lists, and not with the Custom list.

Factory Preset: 30 kHz

Range: 1 kHz to 5 MHz

Default Unit: Hz

Remarks: You must be in the EDGE(w/GSM) mode to use this command.
Use INSTRument:SElect to set the mode.

EDGE Output RF Spectrum—Resolution BW For Switching Transients At Far Offsets

```
[ :SENSe ] :EORFspectr :BANDwidth | BWIDth [ :RESolution ]  
:SWITching :OFFSet :FAR <freq>
```

```
[ :SENSe ]:EORFspectr:BAWdwidth|BWIDth[:RESolution]
:SWITching:OFFSet:FAR?
```

Set the resolution bandwidth used for the spectrum due to switching transients part of the EORF measurement for offset frequencies greater than or equal to 1800 kHz.

This parameter is only used with the standard or short lists, and not with the custom list.

Factory Preset: 30 kHz

100 kHz

Range: 1 kHz to 5 MHz

Default Unit: Hz

Remarks: You must be in the EDGE(w/GSM) mode to use this command.
Use INSTRument:SElect to set the mode.

EDGE Output RF Spectrum—Break Frequency

```
[ :SENSe ]:EORFspectr:BFRequency <freq>
```

```
[ :SENSe ]:EORFspectr:BFRequency?
```

LP: keep the ORFS meas tracking with this command.

Set the direct time break frequency. An FFT measurement method is used for offsets below this break frequency. The direct time measurement method is used for offsets above the break frequency. See the Making EDGE (with GSM) Measurement chapter for more information about these two methods.

Factory Preset: 600 kHz

Range: 0 kHz to 775 kHz

Default Unit: Hz

Remarks: You must be in the EDGE(w/GSM) mode to use this command.
Use INSTRument:SElect to set the mode.

Front Panel

Access: **Meas Setup, Advanced, Direct Time Break Freq**

EDGE Output RF Spectrum—Peak Detection mode

```
[ :SENSe ]:ORFSpectrum:DETEctor:SWITching:FAST[:STATE]OFF|ON|
0|1
```

```
[ :SENSe ]:ORFSpectrum:DETEctor:SWITching?
```

Sets the detection mode to “fast peak”. This setting functions when “measurement type” selected is Switching or Switching & Modulation.

SENSE Subsystem

Factory Preset: On

Remarks: You must be in the GSM or EDGE mode to use this command.
Use INSTRUMENT:SElect to set the mode.

Front Panel

Access: **Meas Setup, More (1 of 2), Advanced**

State Saved: Saved in Instrument State

EDGE Output RF Spectrum—Define Custom Modulation Resolution Bandwidth List

```
[ :SENSE ] :EORFspectr:LIST:MODulation: BANDwidth | BWIDth  
<res bw> { , <res bw> }
```

```
[ :SENSE ] :EORFspectr:LIST:MODulation: BANDwidth | BWIDth ?
```

Define the custom set of resolution bandwidths for the modulation spectrum part of the EORF measurement. The first bandwidth specified is for the carrier. Each resolution bandwidth in this list corresponds to an offset frequency in the modulation offset frequency list. The number of items in each of these lists needs to be the same.

Factory Preset: Same as standard list

Range: 1 kHz to 5 MHz

Default Unit: Hz

Remarks: This command is only valid if SENS:EORF:MEAS is set to multiple and the custom list type is selected with SENS:EORF:LIST:SEL CUST.

You must be in the EDGE(w/GSM) mode to use this command.
Use INSTRUMENT:SElect to set the mode.

EDGE Output RF Spectrum—Define Custom Modulation Offset Frequency List

```
[ :SENSE ] :EORFspectr:LIST:MODulation [ :FREQUENCY ]  
<offset freq> { , <offset freq> }
```

```
[ :SENSE ] :EORFspectr:LIST:MODulation [ :FREQUENCY ] ?
```

Define the custom set of offset frequencies at which the modulation spectrum part of the EORF measurement will be made. The first offset specified must be 0 Hz for the carrier. For each offset frequency specified, the power will be measured at both the lower and upper offsets. Up to 14 (+ the 0 Hz carrier frequency) offset frequencies may be defined.

Factory Preset: Same as standard list

Range: 10 kHz to 10 MHz

Default Unit: Hz

Remarks: This command is only valid if SENS:EORF:MEAS is set to multiple and the custom list type is selected with SENS:EORF:LIST:SEL CUST.

You must be in the EDGE(w/GSM) mode to use this command. Use INSTRUMENT:SElect to set the mode.

EDGE Output RF Spectrum—Define Custom Modulation Level Offsets

```
[ :SENSe ] : EORFspectr : LIST : MODulation : LOFFset
<level> { , <level> }
```

```
[ :SENSe ] : EORFspectr : LIST : MODulation : LOFFset ?
```

Define the custom set of level offsets for the modulation spectrum part of the EORF measurement. This allows you to modify the standard limits by adding a delta amplitude value to them. The first level offset specified must be 0 dB for the carrier. Each level offset in this list corresponds to an offset frequency in the modulation offset frequency list. The number of items in each of these lists needs to be the same.

Example: EORF:LIST:MOD:FREQ 0,300e3,1.3e6,2.0e6
Sets custom offset freqs: 300 kHz, 1.3 MHz, 2 MHz

EORF:LIST:MOD:BAND 30e3,30e3,30e3,100e3
Sets corresponding RBWs: 30 kHz, 30 kHz, 100 kHz

EORF:LIST:MOD:loffset 0,-5,3,5

Assume the power level of the signal is -43 dBm, then the standard limits for these three offsets are: -42 dBc, -72 dBc, -75 dBc respectively. The loffset command adjusts these limits to: -47 (-42-5) dBc, -70 (-73+3) dBc, -70 (-75+5) dBc.

Factory Preset: 0 dB level offsets (limits remain the same as the standards)

Range: 0 to 50 dB

Default Unit: dB

Remarks: This command is only valid if SENS:EORF:MEAS is set to multiple and the custom list type is selected with SENS:EORF:LIST:SEL CUST.

You must be in the EDGE(w/GSM) mode to use this command. Use INSTRUMENT:SElect to set the mode.

SENSe Subsystem

EDGE Output RF Spectrum—Offset Frequency List

```
[ :SENSe ] :EORFspectr :LIST :SElect CUSTom | SHORt | STANdard  
[ :SENSe ] :EORFspectr :LIST :SElect ?
```

Select the list of settings that will be used to make the EORF measurement. This specifies standard or customized lists and short lists. The lists contain the offset frequencies (and bandwidths) that are used for the modulation spectrum and transient spectrum parts of the EORF measurement.

CUSTom - uses the four user-defined lists that specify:

- Offset frequencies for modulation spectrum measurement
- Corresponding resolution bandwidths for each of the modulation offset frequencies
- Offset frequencies for switching transient spectrum measurement
- Corresponding resolution bandwidths for each of the switching transient offset frequencies

SHORt - a shortened list of the offset frequencies specified in the EDGE Standards. It uses two internal offset frequency lists, one for modulation spectrum and the other for switching transient spectrum. These offset frequencies cannot be changed, but the resolution bandwidths can be changed by other commands in the SENSe:EORFpectr subsystem.

STANdard - the complete list of the offset frequencies specified in the EDGE Standards, except for those offsets greater than 6 MHz. It uses two internal offset frequency lists, one for modulation spectrum and the other for switching transient spectrum. These offset frequencies cannot be changed, but the resolution bandwidths can be changed by other commands in the SENSe:EORFpectr subsystem.

Factory Preset: SHORt

Remarks: This command is only valid if SENS:EORF:MEAS is set to multiple.

If you change the number of custom offsets then the number of offset bandwidths, frequencies and level offsets must also be changed.

You must be in the EDGE(w/GSM) mode to use this command. Use INSTRUMENT:SElect to set the mode.

EDGE Output RF Spectrum—Define Custom Switching Transient Resolution Bandwidth List

```
[ :SENSe ] :EORFspectr :LIST :SWITching :BANDwidth | BWIDth  
<res bw> { , <res bw> }  
[ :SENSe ] :EORFspectr :LIST :SWITching :BANDwidth | BWIDth ?
```

Define the custom set of resolution bandwidths for the switching transient

spectrum part of the EORF measurement. The first bandwidth specified is for the carrier. Each resolution bandwidth in this list corresponds to an offset frequency in the switching transient offset frequency list. The number of items in each of these lists needs to be the same.

Factory Preset: Same as standard list

Range: 1 kHz to 5 MHz

Default Unit: Hz

Remarks: This command is only valid if SENS:EORF:MEAS is set to multiple and the custom list type is selected with SENS:EORF:LIST:SEL CUST.

You must be in EDGE(w/GSM) mode to use this command. Use INSTRUMENT:SELect to set the mode.

EDGE Output RF Spectrum—Define Custom Switching Transient Offset Frequency List

```
[ :SENSe ]:EORFspectr:LIST:SWITching[ :FREQuency ]
<offset freq>{ ,<offset freq> }
```

```
[ :SENSe ]:EORFspectr:LIST:SWITching[ :FREQuency ]?
```

Define the custom set of offset frequencies at which the switching transient spectrum part of the EORF measurement will be made. The first offset specified must be 0 Hz, for the carrier. For each offset frequency specified, the power will be measured at both the lower and upper offsets. Up to 14 (+ the 0 Hz carrier frequency) offset frequencies may be defined.

Factory Preset: Same as standard list

Range: 10 kHz to 10 MHz

Default Unit: Hz

Remarks: This command is only valid if SENS:EORF:MEAS is set to multiple and the custom list type is selected with SENS:EORF:LIST:SEL CUST.

You must be in the EDGE(w/GSM) mode to use this command. Use INSTRUMENT:SELect to set the mode.

EDGE Output RF Spectrum—Define Custom Switching Transient Level Offsets

```
[ :SENSe ]:EORFspectr:LIST:SWITching:LOFFset
<level>{ ,<level> }
```

```
[ :SENSe ]:EORFspectr:LIST:SWITching:LOFFset?
```

SENSe Subsystem

Define the custom set of level offsets for the switching transient spectrum part of the EORF measurement. This allows you to modify the standard limits by adding a delta amplitude value to them. The first level offset specified must be 0 dB for the carrier. Each level offset in this list corresponds to an offset frequency in the modulation offset frequency list. The number of items in each of these lists needs to be the same.

Example: See the EORF:LIST:MOD:LOFF example above.

Factory Preset: 0 dB level offsets (limits remain the same as the standards)

Range: 0 to 50 dB

Default Unit: dB

Remarks: This command is only valid if SENS:EORF:MEAS is set to multiple and the custom list type is selected with SENS:EORF:LIST:SEL CUST.

You must be in EDGE(w/GSM) mode to use this command. Use INSTRUMENT:SElect to set the mode.

EDGE Output RF Spectrum—Measure Offsets Measurement Method

[:SENSe] :EORFspectr:MEASure MULTiple | SINGLE

[:SENSe] :EORFspectr:MEASure?

Select the measurement method to be used.

MULTiple - the measurement is done at all offsets in the offset frequency list.

SINGLE - the measurement is done at only one offset as determined by the offset frequency setting. This allows detailed examination of the time-domain waveform at the specified offset frequency.

Factory Preset: MULTiple

Remarks: You must be in the EDGE(w/GSM) mode to use this command. Use INSTRUMENT:SElect to set the mode.

EDGE Output RF Spectrum—Offset Frequency]

[:SENSe] :EORFspectr:OFRequency <freq>

[:SENSe] :EORFspectr:OFRequency?

Set the offset frequency that is used to measure a single offset. This command is only valid if SENS:EORF:MEAS is set to single.

Factory Preset: 250 kHz

Range: -12.0 MHz to +12.0 MHz, step size: steps through the values in the selected offset frequency list.

Default Unit: Hz

Remarks: You must be in the EDGE(w/GSM) mode to use this command.
Use INSTRUMENT:SElect to set the mode.

EDGE Output RF Spectrum—Trigger Source

**[:SENSE] :EORFspectr :TRIGger :SOURce
EXTernal [1] | EXTernal2 | FRAME | IMMEDIATE | RFBURst**

[:SENSE] :EORFspectr :TRIGger :SOURce?

Select the trigger source used to control the data acquisitions.

EXTernal 1 - front panel external trigger input

EXTernal 2 - rear panel external trigger input

FRAME - uses the internal frame timer, which has been synchronized to the selected burst sync

IMMEDIATE - the next data acquisition is immediately taken, capturing the signal asynchronously (also called free run)

RFBURst - wideband RF burst envelope trigger that has automatic level control for periodic burst signals

Factory Preset: RFBURst

Remarks: You must be in the EDGE(w/GSM) mode to use this command.
Use INSTRUMENT:SElect to set the mode.

EDGE Output RF Spectrum—Measurement Type

**[:SENSE] :EORFspectr :TYPE
MODulation | MSWitching | SWITching | FFModulation**

[:SENSE] :EORFspectr :TYPE?

Select the measurement type.

MODulation - only the modulation spectrum is measured.

MSWitching (Modulation & Switching)- both modulation and switching transient spectrums are measured.

SWITching - only the switching transient spectrum is measured.

FFModulation- full frame modulation improves measurement speed by acquiring a full frame of data prior to performing the FFT calculation. FFT modulation can only be used if all slots in the transmitted frame are active.

Factory Preset: MODulation

Remarks: You must be in the GSM, EDGE mode to use this command.

SENSE Subsystem

Use INSTRUMENT:SELEct to set the mode.

History: Added in version A.05.00

EDGE Output RF Spectrum—Select Modulation Method

```
[ :SENSE ] :EORFspectr :TYPE :MODulation [ :METHOD ] DIScrete | SWEEP
```

```
[ :SENSE ] :EORFspectr :TYPE :MODulation [ :METHOD ] ?
```

Selects discrete or sweep modulation method.

Discrete - Measures RF output spectrum at preset frequency offsets. Results are returned in tabular form.

Sweep - Measures output RF spectrum from -1.8 MHz to +1.8 MHz offset in approximately 10 kHz steps. Results are returned as a trace.

Remarks: You must be in the EDGE(w/GSM), GSM mode to use this command. Use INSTRUMENT:SELEct to set the mode.

History: For E4406A: Added in version A.05.00

EDGE Power vs. Time (Burst Power) Measurement

Commands for querying the power versus time measurement results and for setting to the default values are found in the “MEASure Group of Commands” on [page 193](#). The equivalent front panel keys for the parameters described in the following commands, are found under the **Meas Setup** key, after the **EDGE PwT** measurement has been selected from the **MEASURE** key menu.

History: For E4406A: the EPVT measurement was added in version A.04.00.

EDGE Power vs. Time—Number of Bursts Averaged

```
[ :SENSe ]:EPVTime:AVERAge:COUNT <integer>
```

```
[ :SENSe ]:EPVTime:AVERAge:COUNT?
```

Set the number of bursts that will be averaged. After the specified number of bursts (average counts), the averaging mode (terminal control) setting determines the averaging action.

Factory Preset: 10

Range: 1 to 10,000

Remarks: You must be in the EDGE(w/GSM) mode to use this command. Use INSTRument:SElect to set the mode.

EDGE Power vs. Time—Averaging State

```
[ :SENSe ]:EPVTime:AVERAge[ :STATe ] OFF | ON | 0 | 1
```

```
[ :SENSe ]:EPVTime:AVERAge[ :STATe ]?
```

Turn averaging on or off.

Factory Preset: OFF

Remarks: You must be in the EDGE(w/GSM) mode to use this command. Use INSTRument:SElect to set the mode.

EDGE Power vs. Time—Averaging Mode

```
[ :SENSe ]:EPVTime:AVERAge:TCONtrol EXPOnential | REPEAT
```

```
[ :SENSe ]:EPVTime:AVERAge:TCONtrol?
```

Select the type of termination control used for the averaging function. This specifies the averaging action after the specified number of bursts (average count) is reached.

EXPOnential - Each successive data acquisition after the average count is

SENSe Subsystem

reached is exponentially weighted and combined with the existing average.

REPeat - After reaching the average count, the averaging is reset and a new average is started.

Factory Preset: EXPOnential

Remarks: You must be in the EDGE(w/GSM) mode to use this command.
Use INSTrument:SELEct to set the mode.

EDGE Power vs. Time—Averaging Type

```
[ :SENSe ] :EPVTime :AVERAge :TYPE  
LOG | MAXimum | MINimum | MXMinimum | RMS
```

```
[ :SENSe ] :EPVTime :AVERAge :TYPE?
```

Select the type of averaging to be performed.

LOG - The log of the power is averaged. (This is also known as video averaging.)

MAXimum - The maximum values are retained.

MINimum - The minimum values are retained.

MXMinimum - Both the maximum and the minimum values are retained.

RMS - The power is averaged, providing the rms of the voltage.

Factory Preset: RMS

Remarks: You must be in the EDGE(w/GSM) mode to use this command.
Use INSTrument:SELEct to set the mode.

EDGE Power vs. Time—Resolution BW

```
[ :SENSe ] :EPVTime :BANDwidth | BWIDth [ :RESolution ] <freq>
```

```
[ :SENSe ] :EPVTime :BANDwidth | BWIDth [ :RESolution ]?
```

Set the resolution BW. This is an advanced control that normally does not need to be changed. Setting this to a value other than the factory default, may cause invalid measurement results.

Factory Preset: 500 kHz

Range: 1 kHz to 5 MHz

Default Unit: Hz

Remarks: You must be in the EDGE(w/GSM) mode to use this command.
Use INSTrument:SELEct to set the mode.

EDGE Power vs. Time—RBW Filter Type

```
[ :SENSe ]:EPVTime:BAWidTh|BWIDTh[:RESolution]:TYPE
FLATtop|GAUSSian
```

```
[ :SENSe ]:EPVTime:BAWidTh|BWIDTh[:RESolution]:TYPE?
```

Select the type of resolution BW filter. This is an advanced control that normally does not need to be changed. Setting this to a value other than the factory default, may cause invalid measurement results.

FLATtop - a filter with a flat amplitude response, which provides the best amplitude accuracy.

GAUSSian - a filter with Gaussian characteristics, which provides the best pulse response.

Factory Preset: GAUSSian

Remarks: You must be in the EDGE(w/GSM) mode to use this command.
Use INSTRument:SElect to set the mode.

EDGE Power vs. Time—Burst Synchronization Source

```
[ :SENSe ]:EPVTime:BSYNc:SOURce RFBurst|TSEquence
```

```
[ :SENSe ]:EPVTime:BSYNc:SOURce?
```

Select the method of synchronizing the measurement to the EDGE bursts.

RFBurst - the RF burst sync approximates the start and stop of the useful part of the burst without digital demodulation of the burst.

TSEquence - the training sequence burst sync performs a demodulation of the burst and determines the start and stop of the useful part of the burst based on the midamble training sequence.

Factory Preset: TSEquence

Remarks: You must be in the EDGE(w/GSM) mode to use this command.
Use INSTRument:SElect to set the mode.

EDGE Power vs. Time—Limit Line Mask Display

```
[ :SENSe ]:EPVTime:LIMit:MASK OFF|ON|0|1
```

```
[ :SENSe ]:EPVTime:LIMit:MASK?
```

Show or hide the limit mask. Does not affect limit pass/fail calculation.

Same as :DISPlay:EPVTime:LIMit:MASK. The sense version was added to be compatible/consistent with ESA.

Factory Preset: ON

SENSE Subsystem

Range: ON/OFF

Remarks: You must be in GSM mode to use this command. Use INSTRUMENT:SElect to set the mode.

EDGE Power vs. Time—Lower Mask Absolute Amplitude Levels

```
[ :SENSE ] :EPVTime :MASK :LIST :LOWer :ABSolute <power> , <power> ,  
<power> , <power> , <power>
```

```
[ :SENSE ] :EPVTime :MASK :LIST :LOWer :ABSolute?
```

Enter a power level for any of your mask line segments that require an absolute minimum power limit in addition to its relative limit. Each time a measurement is made the Ref Level is determined. (This is the power level of the useful part of the burst, or midway between the upper/lower masks). Remember, as the power of the Ref Level changes, all of the relative mask power levels will change by the same amount.

Each relative limit is then compared to the Ref Level and an equivalent absolute power level is calculated. This power level is compared to the specified absolute limit for each line segment. If this calculated relative limit is lower than the absolute limit you've specified, then the value of the absolute limit is used for this segment. Therefore, if the absolute limit is set to a very low value (–200 dBm), the calculated value of the reference limit will never be lower, and the specified relative limit will always be used for that segment. See [Figure 0-4 on page 398](#).

Every time point you defined with PVT:MASK:LOW:TIME must have a power value defined in the same order. You can put a comma in the SCPI command as a place holder for any points where an absolute power is not specified, and that segment will then use the default value.

Factory Preset: Selected EDGE standard

Range: –200 dBm to +100 dBm

Default Unit: dBm

Remarks: You must be in EDGE(w/GSM) mode to use this command. Use INSTRUMENT:SElect to set the mode.

EDGE Power vs. Time—Lower Mask Points

```
[ :SENSE ] :EPVTime :MASK :LIST :LOWer :POINTs?
```

Query the number of elements in the lower mask. This value is determined by the number of time points entered using

```
[ :SENSE ] :EPVTime :MASK :LIST :LOWer :TIME.
```

Range: integer, 1 to 25

Remarks: You must be in EDGE(w/GSM) mode to use this command. Use

INSTRument:SElect to set the mode.

EDGE Power vs. Time—Lower Mask Relative Amplitude Levels

```
[ :SENSe ]:EPVTime:MASK:LIST:LOWer:RELative <rel_power>,
<rel_power>, <rel_power>, <rel_power>, <rel_power>
```

```
[ :SENSe ]:EPVTime:MASK:LIST:LOWer:RELative?
```

Enter the relative power level for each horizontal line segment in the lower limit mask. There should be a power level for each time point entered using [:SENSe]:EPVTime:MASK:LIST:LOWer:TIME, and they must be entered in the same order. These power levels are all relative to the defined Reference Power Level (the average power in the useful part of the data).

Any portion of the signal that has no limit line segment defined for it, will default to a very low limit (–100 dB relative to the reference power). This will keep the measurement from indicating a failure for that portion of the data.

Factory Preset: Selected EDGE standard

Range: +200 dB to –100 dB, relative to the reference power

Default Unit: dB

Remarks: You must be in EDGE(w/GSM) mode to use this command. Use INSTRument:SElect to set the mode.

EDGE Power vs. Time—Lower Mask Time Points

```
[ :SENSe ]:EPVTime:MASK:LIST:LOWer:TIME <seconds>, <seconds>,
<seconds>, <seconds>, <seconds>
```

```
[ :SENSe ]:EPVTime:MASK:LIST:LOWer:TIME?
```

Enter the time points that define the horizontal line segments of the lower limit. A reference point designated “ t_0 ” is at the center of the useful data (usually the center of the burst). Each line segment to the right of the t_0 reference point is designated as a positive time value and each segment to the left of t_0 is a negative time value.

First enter positive values in sequence starting from t_0 , then negative values in sequence starting from t_0 . See [Figure 0-4 on page 398](#) and the

[:SENSe]:EPVT:MASK:LIST:UPPER:TIME example below it. (This is an upper mask example, but they work the same.)

We recommend that you select a large time value for your first and last mask points (e.g. –1 and +1 second). This guarantees that you’ve defined a limit for all the measured data. (See Mask Segments 4 and 9 in the [Table on page 398](#) for an example.)

Factory Preset: Selected EDGE standard

SENSe Subsystem

Range: –1s to +1s, referenced to t_0 at the center of the useful data (burst center)
 1 to 25 time points in a mask

Default Unit: seconds

Remarks: You must be in the EDGE(w/GSM) mode to use this command.
 Use INSTRument:SElect to set the mode.

EDGE Power vs. Time—Custom Limit Masks

```
[ :SENSe ] :EPVTime :MASK :SElect STANDARD|CUSTOM
```

```
[ :SENSe ] :EPVTime :MASK :SElect?
```

Select standard masks or user-defined custom masks to compare you measured data against.

Factory Preset: STANDARD

Remarks: You must be in EDGE(w/GSM) mode to use this command. Use INSTRument:SElect to set the mode.

EDGE Power vs. Time—Upper Mask Absolute Amplitude Levels

```
[ :SENSe ] :EPVTime :MASK :LIST :UPPer :ABSolute <power>, <power>, <power>, <power>, <power>
```

```
[ :SENSe ] :EPVTime :MASK :LIST :UPPer :ABSolute?
```

Enter a power level for any of your mask line segments that require an absolute minimum power limit in addition to its relative limit. Each time a measurement is made the Ref Level is determined. (This is the power level of the useful part of the burst, or midway between the upper/lower masks). Remember, as the power of the Ref Level changes, all of the relative mask power levels will change by the same amount.

Each relative limit is then compared to the Ref Level and an equivalent absolute power level is calculated. This power level is compared to the specified absolute limit for each line segment. If this calculated relative limit is lower than the absolute limit you've specified, then the value of the absolute limit is used for this segment. Therefore, if the absolute limit is set to a very low value (–200 dBm), the calculated value of the reference limit will never be lower, and the specified relative limit will always be used for that segment. See [Figure 0-4 on page 398](#).

Every time point you defined with PVT:MASK:LOW:TIME must have a power value defined in the same order. You can put a comma in the SCPI command as a place holder for any points where an absolute power is not specified, and that segment will then use the default value.

Example: **EPVT:MASK:LIST:UPP:ABS -200, -200, -58, -200, -200, -200, -200, -58, -200**

Factory Preset: Selected EDGE standard

Range: -200 dBm to +100 dBm

Default Unit: dBm

Remarks: You must be in EDGE(w/GSM) mode to use this command. Use INSTRUMENT:SELEct to set the mode.

EDGE Power vs. Time—Upper Mask Points

[:SENSE] : EPVTime : MASK : LIST : UPPer : POINTs ?

Query the number of elements in the upper mask. This value is determined by the number of time points entered using

[:SENSE] : EPVTime : MASK : LIST : UPPer : TIME.

Range: integer, 1 to 25

Remarks: You must be in EDGE(w/GSM) mode to use this command. Use INSTRUMENT:SELEct to set the mode.

EDGE Power vs. Time—Upper Mask Relative Amplitude Levels

[:SENSE] : EPVTime : MASK : LIST : UPPer : RELative <rel_power>, <rel_power>, <rel_power>, <rel_power>

[:SENSE] : EPVTime : MASK : LIST : UPPer : RELative ?

Enter the relative power level for each horizontal line segment in the upper limit mask. There should be a power level for each time point entered using **[:SENSE] : EPVTime : MASK : LIST : UPPer : TIME**, and they must be entered in the same order. These power levels are all relative to the defined Reference Power Level (the average power in the useful part of the data). See [Figure 0-4 on page 398](#).

Figure 0-4 Custom Upper Limit Mask Example

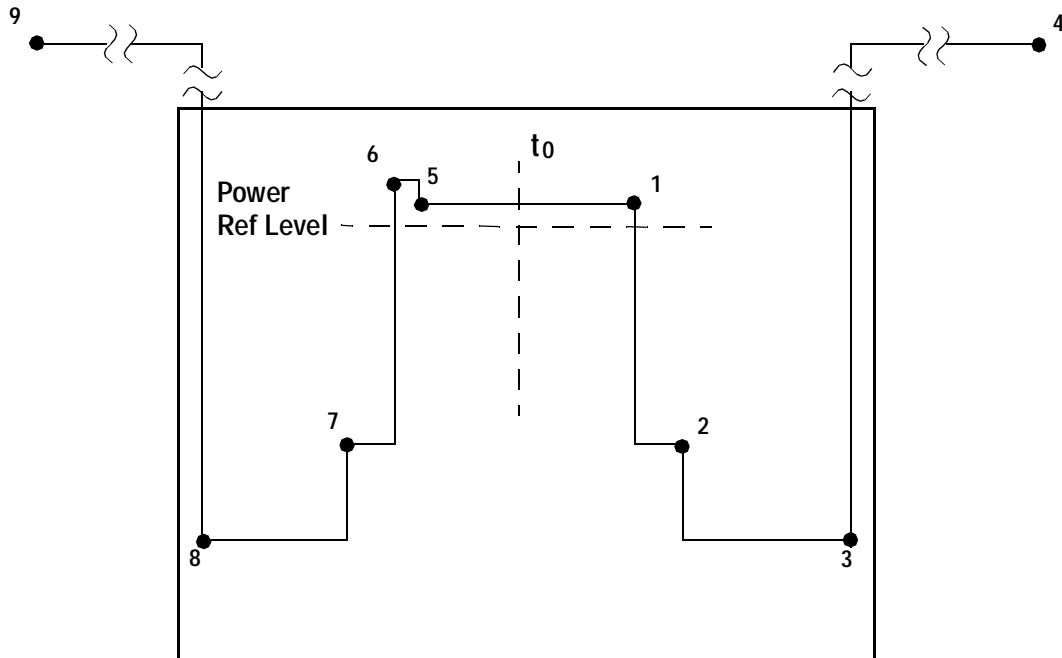

Entered Value for each Time Segment	Absolute Time Value	Relative Power (example (with Ref Level = -12 dBm))		Entered Absolute Power (dBm)	Segment Number
		Entered Relative Power	Equivalent Absolute Power		
280.0e-6	280 μ s	+4 dBc	-8 dBm	-200 dBm	1
15.0e-6	295 μ s	-32 dBc	-44 dBm	-200 dBm	2
450.0e-6	745 μ s	-48 dBc	-60 dBm ^a	-58 dBm ^a	3
1	>1 sec	+100 dBc	+112 dBm	-200 dBm	4
-270.0e-6	-270 μ s	+4 dBc	-8 dBm	-200 dBm	5
-10.0e-6	-280 μ s	+7 dBc	-5 dBm	-200 dBm	6
-20.0e-6	-300 μ s	-25 dBc	-37 dBm	-200 dBm	7
-450e-6	-750 μ s	-43 dBc	-55 dBm	-58 dBm	8
-1	<-1 sec	+100 dBc	+112 dBm	-200 dBm	9

- a. Notice that this segment, with this value of Ref Level, has a calculated relative level of -60 dBm. This is lower than the specified absolute level of -58 dBm, so the -58 dBm value will be used as the test limit for the segment.

Example: `EPVT:MASK:LIST:UPP:REL 4, -32, -48, 100, 4, 7, -25, -43, 100`

Factory Preset: Selected EDGE standard
 Range: 200 dB to –100 dB, relative to the reference power
 Default Unit: dB
 Remarks: You must be in EDGE(w/GSM) mode to use this command. Use INSTRUMENT:SElect to set the mode.

EDGE Power vs. Time—Upper Mask Time Points

```
[ :SENSe ]:EPVTime:MASK:LIST:UPPER:TIME <seconds>, <seconds>, <seconds>, <seconds>, <seconds>
```

```
[ :SENSe ]:EPVTime:MASK:LIST:UPPER:TIME?
```

Enter the time points that define the horizontal line segments of the upper limit. A reference point designated “ t_0 ” is at the center of the useful data (usually the center of the burst). Each line segment to the right of the t_0 reference point is designated as a positive value and each segment to the left of t_0 is a negative value.

First enter positive values in sequence starting from t_0 , then the negative values in sequence starting from t_0 . See [Figure 0-4 on page 398](#) and the EPVT:MASK:LIST:UPPER:TIME example below it.

We recommend that you select a large time value for your first and last mask points (e.g. –1 and +1 second). This guarantees that you’ve defined a limit for all the measured data. (See Mask Segments 4 and 9 in the [Table on page 398](#) for an example.

```
Example: EPVT:MASK:LIST:UPP:TIME 280e-6, 15e-6, 1, -270e-6, -10e-6, -20e-6, -1
```

Factory Preset: Selected EDGE standard
 Range: –1s to +1s, referenced to t_0 at the center of the useful data (burst center)
 1 to 25 time points in a mask
 Default Unit: seconds
 Remarks: You must be in the EDGE(w/GSM) mode to use this command. Use INSTRUMENT:SElect to set the mode.

EDGE Power vs Time - Select Power Control Level

Allows user to indicate the output power of the transmitter; in MS testing transmitter output power level will affect the mask. The appropriate power level for measuring the device under test will correspond with the transmitter power control level setting.

```
[ :SENSe ]:EPVTime:PCLevel <integer>
```

SENSe Subsystem

[:SENSe] :EPVTime :PCLevel ?

Range: 0 to 40

Remarks: You must be in the power vs. time measurement in GSM or EDGE(w/GSM) mode to use this command. Use INSTRument:SElect to set the mode

Front Panel Access: **Meas Setup, More (1 of 2), Pwr Cntrl Lvl.**

History: For E4406A: added in Version A.05.00

EDGE Power vs. Time—Sweep Time

[:SENSe] :EPVTime :SWEep :TIME <integer>

[:SENSe] :EPVTime :SWEep :TIME ?

Set the number of slots which are used in each data acquisition. Each slot is approximately equal to 570 ms. The measurement is made for a small additional amount of time (about 130 μ s) in order to view the burst edges.

Factory Preset: 1

Range: 1 to 8 (for resolution BW = 500 kHz)

Remarks: You must be in the EDGE(w/GSM) mode to use this command. Use INSTRument:SElect to set the mode.

EDGE Power vs. Time—Trigger Source

[:SENSe] :EPVTime :TRIGger :SOURCE EXTERNAL[1] | EXTERNAL2 | FRAME | IF | IMMEDIATE | RFBURST

[:SENSe] :EPVTime :TRIGger :SOURCE ?

Select the trigger source used to control the data acquisitions.

EXTERNAL 1 - front panel external trigger input

EXTERNAL 2 - rear panel external trigger input

FRAME - uses the internal frame timer, which has been synchronized to the selected burst sync.

IF - internal IF envelope (video) trigger

IMMEDIATE - the next data acquisition is immediately taken, capturing the signal asynchronously (also called Free Run).

RFBURST - wideband RF burst envelope trigger that has automatic level control for periodic burst signals.

Factory Preset: RFBURST

Remarks: You must be in the EDGE(w/GSM) mode to use this command.

Use INSTRument:SElect to set the mode.

EDGE Transmit Band Spurs Measurement

Commands for querying the EDGE transmit band spurs measurement results and for setting to the default values are found in the “[MEASure Group of Commands](#)” on page 193. The equivalent front panel keys for the parameters described in the following commands, are found under the **Meas Setup** key, after the **EDGE TxBand Spur** measurement has been selected from the **MEASURE** key menu.

History: E4406A:
The EDGE version of the GSM transmit band spurs measurement was added in version A.05.00

Transmit Band Spurs—Average Count

[:SENSe] :ETSPur :AVERAge :COUNT <integer>

[:SENSe] :ETSPur :AVERAge :COUNT?

Set the number of data acquisitions that will be averaged. After the specified number of average counts, the averaging mode (terminal control) setting determines the averaging action.

Factory Preset: 30

Range: 1 to 10,000

Remarks: You must be in the EDGE(w/GSM) mode to use this command.
Use INSTRument:SELEct to set the mode.

History: E4406A:
Added in version A.05.00

Transmit Band Spurs—Averaging State

[:SENSe] :ETSPur :AVERAge [:STATe] OFF | ON | 0 | 1

[:SENSe] :ETSPur :AVERAge [:STATe]?

Turn averaging on or off.

Factory Preset: ON

Remarks: You must be in the EDGE(w/GSM) mode to use this command.
Use INSTRument:SELEct to set the mode.

History: E4406A:
Added in version A.05.00

Transmit Band Spurs—Averaging Termination Control

[:SENSe] :ETSPur :AVERAge :TCONtrol EXPonential | REPeat

[:SENSe] :ETSPur :AVERAge :TCONtrol?

Select the type of termination control used for the averaging function. This determines the averaging action after the specified number of data acquisitions (average count) is reached.

EXPonential - Each successive data acquisition after the average count is reached, is exponentially weighted and combined with the existing average.

REPeat - After reaching the average count, the averaging is reset and a new average is started.

Factory Preset: REPeat

Remarks: You must be in the EDGE(w/GSM) mode to use this command.
Use INSTRument:SElect to set the mode.

History: E4406A:
Added in version A.05.00

Transmit Band Spurs—Averaging Type

[:SENSe] :ETSPur :AVERAge :TYPE LOG | MAXimum | RMS

[:SENSe] :ETSPur :AVERAge :TYPE?

Select the type of averaging.

LOG - The log of the power is averaged. (This is also known as video averaging.)

MAXimum - The maximum values are retained.

RMS - The power is averaged, providing the rms of the voltage.

Factory Preset: MAXimum

Remarks: You must be in the EDGE(w/GSM) mode to use this command.
Use INSTRument:SElect to set the mode.

History: E4406A:
Added in version A.05.00

Transmit Band Spurs—Type

[:SENSe] :ETSPur :TYPE EXAMine | FULL

[:SENSe] :ETSPur :TYPE?

Select the measurement type.

EXAMine - measures spurs in all the valid segments and then displays the segment that has the worst spur

FULL - continuously measures the spurs in all the valid segments

Factory Preset: FULL

SENSe Subsystem

Remarks: You must be in the EDGE(w/GSM) mode to use this command.
 Use INSTrument:SELEct to set the mode.

History: E4406A:
 Added in version A.05.00

Error Vector Magnitude Measurement

Commands for querying the error vector magnitude measurement results and for setting to the default values are found in the “MEASure Group of Commands” on [page 193](#). The equivalent front panel keys for the parameters described in the following commands, are found under the **Meas Setup** key, after the **EVM** measurement has been selected from the **MEASURE** key menu.

Error Vector Magnitude—Average Count

[:SENSe] :EVM:AVERAge:COUNT <integer>

[:SENSe] :EVM:AVERAge:COUNT?

Set the number of data acquisitions that will be averaged. After the specified number of average counts, the average mode (termination control) setting determines the average action.

Factory Preset: 10

Range: 1 to 10,000

Remarks: You must be in the NADC or PDC mode to use this command.
Use INSTRument:SElect to set the mode.

Error Vector Magnitude—Averaging State

[:SENSe] :EVM:AVERAge [:STATe] OFF | ON | 0 | 1

[:SENSe] :EVM:AVERAge [:STATe]?

Turn average on or off.

Factory Preset: ON

Remarks: You must be in the NADC or PDC mode to use this command.
Use INSTRument:SElect to set the mode.

Error Vector Magnitude—Averaging Termination Control

[:SENSe] :EVM:AVERAge:TCONtrol EXPOnential | REPeat

[:SENSe] :EVM:AVERAge:TCONtrol?

Select the type of termination control used to averaging. This determines the averaging action after the specified number of data acquisitions (average count) is reached.

EXPOnential – Each successive data acquisition after the average count is reached, is exponentially weighted and combined with the existing average.

REPeat – After reaching the average count, the averaging is reset and a new average is started.

SENSe Subsystem

Factory Preset: EXPOnential

Remarks: You must be in the NADC or PDC mode to use this command.
Use INSTRument:SELEct to set the mode.

Error Vector Magnitude—Burst Synchronization Source

[:SENSe] :EVM:BSYNc:SOURce RFAMplitude | SWORd | NONE

[:SENSe] :EVM:BSYNc:SOURce?

Select the method of synchronizing the measurement to the bursts.

RFAMplitude – The burst sync approximates the start and stop of the useful part of the burst without demodulation of the burst. The measurement is then synchronized with the center point of the burst.

SWORd – The measurement is synchronized with the synch word.

NONE – The measurement is performed without searching burst.

Factory Preset: NONE for BS

SWORd for MS

Remarks: You must be in the NADC or PDC mode to use this command.
Use INSTRument:SELEct to set the mode.

Error Vector Magnitude—Points/Symbol

[:SENSe] :EVM:TRACe:PPSYmbol <integer>

[:SENSe] :EVM:TRACe:PPSYmbol?

Select the points/symbol for EVM measurement. Only 1 or 5 are valid entries.

Factory Preset: 5

Range: 1, 5

Remarks: You must be in the NADC or PDC mode to use this command.
Use INSTRument:SELEct to set the mode.

Error Vector Magnitude—Trigger Source

**[:SENSe] :EVM:TRIGger:SOURce
EXTErnal[1] | EXTErnal2 | FRAME | IF | IMMEDIATE | RFBurst**

[:SENSe] :EVM:TRIGger:SOURce?

Select the trigger source used to control the data acquisitions.

EXTErnal 1 – front panel external trigger input

EXTernal 2 – rear panel external trigger input

IF – internal IF envelope (video) trigger

IMMediate – the next data acquisition is immediately taken, capturing the signal asynchronously (also called free run)

FRAMe – internal frame trigger from front panel input

RFBurst – wideband RF burst envelope trigger that has automatic level control for periodic burst signals

Factory Preset: IMMEDIATE for BS

RFBURST for MS

Remarks: You must be in the NADC or PDC mode to use this command.
Use INSTRUMENT:SElect to set the mode.

QPSK Error Vector Magnitude Measurement

Commands for querying the QPSK error vector magnitude measurement results and for setting to the default values are found in the “MEASure Group of Commands” on page 193. The equivalent front panel keys for the parameters described in the following commands, are found under the **Meas Setup** key, after the **QPSK EVM** measurement has been selected from the **MEASURE** key menu.

QPSK Error Vector Magnitude — ADC Range

PSA

```
[ :SENSe ] :EVMQpsk :ADC :RANGe  
AUTO | APEak | APLock | NONE | P0 | P6 | P12 | P18
```

E4406A

```
[ :SENSe ] :EVMQpsk :ADC :RANGe  
AUTO | APEak | APLock | M6 | P0 | P6 | P12 | P18 | P24
```

```
[ :SENSe ] :EVMQpsk :ADC :RANGe?
```

Select a ranging function for the ADC gain control. This is an advanced control that normally does not need to be changed. If you are measuring a CW signal, see the following description:

- **AUTO** - automatic ranging

For FFT spectrums, the auto ranging should not be used. An exception to this would be if you know that your signal is “bursty”. Then you might use auto to maximize the time domain dynamic range as long as you are not very interested in the FFT data.

- **APEak** (Auto Peak) - automatic ranging to the peak signal level

For CW signals, the default of auto-peak ranging can be used, but a better FFT measurement of the signal can be made by selecting one of the manual ranges that is available by specifying M6, or P0 through P24.

Auto peaking can cause the ADC gain to monotonically track the ranges down during the data capture. This tracking effect should be negligible for the FFT spectrum, but selecting a manual range solves this possibility. Note that if the CW signal being measured is close to the auto-ranging threshold, the noise floor may shift as much as 6 dB every sweep.

- **APLock** (Auto Peak Lock) - automatic ranging locked to the peak signal level

For CW signals, auto-peak lock ranging may be used. It will find the ADC gain most appropriate for this particular signal and will not track the ranges as auto-peak can. Note that if the CW signal being measured is close to the auto-ranging threshold, the noise floor may shift as much as 6 dB every sweep.

For “bursty” signals, auto-peak lock ranging should not be used. Since the ADC range can often be locked to the wrong one resulting in overloading the ADC, the measurement will fail.

- **NONE** - (PSA) turns off any auto-ranging without making any changes to the

current setting.

- M6 - (E4406A) manually selects an ADC range that subtracts 6 dB from the fixed gain across the range. Manual ranging is best for CW signals.
- P0 thru P18 - (PSA) manually selects one of the ADC ranges that add 0 dB to 24 dB to the fixed gain across the range. Manual ranging is best for CW signals.
- P0 thru P24 - (E4406A) manually selects one of the ADC ranges that add 0 dB to 24 dB to the fixed gain across the range. Manual ranging is best for CW signals.

Factory Preset: M6

Remarks: You must be in the 1xEV-DO mode to use this command. Use INSTRUMENT:SELEct to set the mode.

History: PSA:
Added in version A.02.00

E4406A:
Added in version A.05.00

QPSK Error Vector Magnitude—Demod Alpha

[:SENSe] :EVMQpsk:ALPHa <numeric>

[:SENSe] :EVMQpsk:ALPHa?

Set alpha for the root Nyquist filter.

Factory Preset: 0.22

Range: 0.01 to 0.5

Remarks: You must be in the W-CDMA mode to use this command. Use INSTRUMENT:SELEct to set the mode.

QPSK Error Vector Magnitude—Average Count

[:SENSe] :EVMQpsk:AVERAge:COUNT <integer>

[:SENSe] :EVMQpsk:AVERAge:COUNT?

Set the number of data acquisitions that will be averaged. After the specified number of average counts, the average mode (termination control) setting determines the average action.

Factory Preset: 10

Range: 1 to 10,000

Remarks: You must be in the cdma2000, W-CDMA, or 1xEV-DO mode to use this command. Use INSTRUMENT:SELEct to set the mode.

QPSK Error Vector Magnitude—Averaging State

[:SENSE] :EVMQpsk :AVERAge [:STATe] OFF | ON | 0 | 1

[:SENSE] :EVMQpsk :AVERAge [:STATe] ?

Turn the averaging function on or off.

Factory Preset: ON

Remarks: You must be in the cdma2000, W-CDMA, or 1xEV-DO mode to use this command. Use INSTRUMENT:SELEct to set the mode.

QPSK Error Vector Magnitude—Averaging Termination Control

[:SENSE] :EVMQpsk :AVERAge :TCONTRol EXPonential | REPEat

[:SENSE] :EVMQpsk :AVERAge :TCONTRol ?

Select the type of termination control used to averaging. This determines the averaging action after the specified number of data acquisitions (average count) is reached.

EXPonential – Each successive data acquisition after the average count is reached, is exponentially weighted and combined with the existing average.

REPEat – After reaching the average count, the averaging is reset and a new average is started.

Factory Preset: REPEat

Remarks: You must be in the cdma2000, W-CDMA, or 1xEV-DO mode to use this command. Use INSTRUMENT:SELEct to set the mode.

QPSK Error Vector Magnitude— Predefine Constellation Type

[:SENSE] :EVMQpsk :CONSt1n QPSK | RMC122

[:SENSE] :EVMQpsk :CONSt1n ?

Select QPSK or RMC12.2k for the predefined constellation on MS. When Device is set to BTS, it is automatically set to QPSK.

QPSK: The reference points are set to QPSK constellation.

RMC122: The reference points are set to the following constellation.

Factory Preset: QPSK

Remarks: You must be in the W-CDMA mode to use this command. Use INSTRUMENT:SElect to set the mode.

QPSK Error Vector Magnitude—Chip Rate

[:SENSE] :EVMQpsk :CRATe <freq>

[:SENSE] :EVMQpsk :CRATe?

Enter a frequency value to set the chip rate.

Factory Preset: 1.2288 MHz for cdma2000, 1xEV-DO

3.84 MHz for W-CDMA

Range: 1.10592 to 1.35168 MHz for cdma2000, 1xEV-DO

3.456 to 4.224 MHz for W-CDMA

Default Unit: Hz

Remarks: You must be in the cdma2000, W-CDMA, or 1xEV-DO mode to use this command. Use INSTRUMENT:SElect to set the mode.

QPSK Error Vector Magnitude—RF Carrier Mode

[:SENSE] :EVMQpsk :RFCarrier MULTiple|SINGLE

[:SENSE] :EVMQpsk :RFCarrier?

Select either the single carrier mode or the multiple carrier mode.

MULTiple – The measurement assumes that the input signal is the multiple carriers with adjacent channel signals. The filter is used to cut the adjacent

SENSE Subsystem

channel signals. (The filter may affect the measurement result.)

SINGLE – The measurement assumes that the input signal is the single carrier without adjacent channel signals. No filter is used for better measurement.

Factory Preset: SINGLE

Remarks: You must be in the cdma2000 or 1xEV-DO mode to use this command. Use INSTRUMENT:SELEct to set the mode.

QPSK Error Vector Magnitude— Spectrum Normal/Invert

```
[ :SENSE ] :EVMQpsk :SPECTrum INVert |NORMal
```

```
[ :SENSE ] :EVMQpsk :SPECTrum?
```

Select inverted or normal spectrum for demodulation.

Factory Preset: NORMAL

Remarks: You must be in the W-CDMA mode to use this command. Use INSTRUMENT:SELEct to set the mode.

QPSK Error Vector Magnitude—Measurement Interval

```
[ :SENSE ] :EVMQpsk :SWEep :POINTs <integer>
```

```
[ :SENSE ] :EVMQpsk :SWEep :POINTs?
```

Set the number of data points that will be used as the measurement interval.

Factory Preset: 256 chips

96 chips for 1xEV-DO

2560 chips (1 slot) for W-CDMA

Range: 128 to 1536 chips for cdma2000

128 to 2560 chips for W-CDMA

32 to 2048 chips for 1xEV-DO

Remarks: You must be in the cdma2000, W-CDMA, or 1xEV-DO mode to use this command. Use INSTRUMENT:SELEct to set the mode.

QPSK Error Vector Magnitude—Measurement Offset

```
[ :SENSE ] :EVMQpsk :SWEep :POINTs :OFFSet <number>
```

```
[ :SENSE ] :EVMQpsk :SWEep :POINTs :OFFSet?
```

Set the number of data points that will be offset.

Factory Preset: 464.0 chips

Range: 22.0 to 2048.0 chips

Remarks: You must be in the 1xEV-DO mode to use this command. Use INSTRUMENT:SElect to set the mode.

History: PSA:
Added in version A.02.00

E4406A:
Added in version A.05.00

QPSK Error Vector Magnitude—Trigger Source

```
[ :SENSe ] :EVMQpsk :TRIGger :SOURce
EXTErnal [ 1 ] | EXTErnal2 | FRAMe | IF | IMMEDIATE | RFBURSt
[ :SENSe ] :EVMQpsk :TRIGger :SOURce?
```

Select one of the trigger sources used to control the data acquisitions.

EXTErnal 1 – front panel external trigger input

EXTErnal 2 – rear panel external trigger input

FRAMe – internal frame trigger

IF – internal IF envelope (video) trigger

IMMEDIATE – the next data acquisition is immediately taken, capturing the signal asynchronously (also called free run)

RFBURSt – wideband RF burst envelope trigger that has automatic level control for periodic burst signals

Factory Preset: IMMEDIATE

Remarks: You must be in the cdma2000, W-CDMA, or 1xEV-DO mode to use this command. Use INSTRUMENT:SElect to set the mode.

RF Input Signal Alignments

Select the Input Signal

(PSA)

```
[ :SENSe ] :FEED RF | AREFERENCE | IFALIGN
```

(E4406A)

```
[ :SENSe ] :FEED RF | IQ | IONLY | QONLY | AREFERENCE | IFALIGN
```

```
[ :SENSe ] :FEED?
```

Selects the input signal. The default input signal is taken from the front panel RF input port. For calibration and testing purposes the input signal can be taken from an internal 321.4 MHz IF alignment signal or an internal 50 MHz amplitude reference source.

For E4406A if the baseband IQ option (Option B7C) is installed, I and Q input ports are added to the front panel. The I and Q ports accept the in-phase and quadrature components of the IQ signal, respectively. The input signal can be taken from either or both ports.

RF selects the signal from the front panel RF INPUT port.

IQ selects the combined signals from the front panel optional I and Q input ports. (E4406A with Option B7C in Basic, W-CDMA, cdma2000, EDGE(w/GSM) modes)

IONLY selects the signal from the front panel optional I input port. (E4406A with Option B7C in Basic mode)

QONLY selects the signal from the front panel optional Q input port. (E4406A with Option B7C in Basic mode)

AREFERENCE selects the internal 50 MHz amplitude reference signal.

IFALIGN selects the internal, 321.4 MHz, IF alignment signal.

Factory Preset: RF

Front Panel

Access: **Input, Input Port**

History: E4406A:
modified in version A.05.00

Frequency Commands

Center Frequency

[:SENSe] :FREQUency:CENTer <freq>

[:SENSe] :FREQUency:CENTer?

Set the center frequency.

Factory Preset: E4406A

1.0 GHz

942.6 MHz for GSM, EDGE

806.0 MHz for iDEN

E4406A

1.0 kHz to 4.3214 GHz

Default Unit: Hz

Front Panel

Access: **FREQUENCY/Channel, Center Freq**

Center Frequency Step Size Automatic

[:SENSe] :FREQUency:CENTer:STEP:AUTO OFF | ON | 0 | 1

[:SENSe] :FREQUency:CENTer:STEP:AUTO?

Specifies whether the step size is set automatically based on the span.

Factory Preset: ON

History: E4406A:
Version A.03.00 or later

Front Panel

Access: **FREQUENCY/Channel, CF Step**

Center Frequency Step Size

[:SENSe] :FREQUency:CENTer:STEP[:INCRement] <freq>

[:SENSe] :FREQUency:CENTer:STEP[:INCRement]?

Specifies the center frequency step size.

Factory Preset: 5.0 MHz (E4406A)

1.25 MHz for cdma2000 (E4406A)

Range: 1.0 kHz to 1.0 GHz, in 10 kHz steps (E4406A)

SENSE Subsystem

Default Unit: Hz
History: E4406A:
Version A.03.00 or later
Front Panel
Access: **FREQUENCY/Channel, CF Step1**

Intermodulation Measurement

Commands for querying the intermodulation measurement results and for setting to the default values are found in the “[MEASURE Group of Commands](#)” on [page 193](#). The equivalent front panel keys for the parameters described in the following commands, are found under the **Meas Setup** key, after the **Intermod** measurement has been selected from the **MEASURE** key menu.

History: E4406A:
Added version A.04.00 and later

Intermodulation—Average Count

[:SENSE] :IM:AVERAGE:COUNT <number>

[:SENSE] :IM:AVERAGE:COUNT?

Set the number of data acquisitions that will be averaged. After the specified number of average counts, the average mode (termination control) setting determines the average action.

Factory Preset: 10
Range: 1 to 10,000
Remarks: You must be in the cdma2000, W-CDMA, or 1xEV-DO mode to use this command. Use INSTRUMENT:SELEct to set the mode.

Intermodulation—Averaging State

[:SENSE] :IM:AVERAGE[:STATE] OFF|ON|0|1

[:SENSE] :IM:AVERAGE[:STATE]?

Turn the averaging function on or off.

Factory Preset: ON
Remarks: You must be in the cdma2000, W-CDMA, or 1xEV-DO mode to use this command. Use INSTRUMENT:SELEct to set the mode.

Intermodulation—Averaging Termination Control

```
[ :SENSe ]:IM:AVERAge:TCONtrol EXPonential|REPeat
```

```
[ :SENSe ]:IM:AVERAge:TCONtrol?
```

Select the type of termination control used for averaging. This determines the averaging action after the specified number of data acquisitions (average count) is reached.

EXPonential – Each successive data acquisition after the average count is reached, is exponentially weighted and combined with the existing average.

REPeat – After reaching the average count, the averaging is reset and a new average is started.

Factory Preset: REPeat

Remarks: You must be in the cdma2000, W-CDMA, or 1xEV-DO mode to use this command. Use INSTRument:SElect to set the mode.

Intermodulation—Integration Bandwidth

```
[ :SENSe ]:IM:BANDwidth|BWIDth:INTEgration <freq>
```

```
[ :SENSe ]:IM:BANDwidth|BWIDth:INTEgration?
```

Set the Integration Bandwidth (IBW) that will be used.

Factory Preset: 1.23 MHz for cdma2000, 1xEV-DO
3.84 MHz for W-CDMA

Range: 100.0 kHz to 5.0 MHz

Default Unit: Hz

Remarks: You must be in the cdma2000, W-CDMA, or 1xEV-DO mode to use this command. Use INSTRument:SElect to set the mode.

Intermodulation—Resolution Bandwidth

```
[ :SENSe ]:IM:BANDwidth|BWIDth[:RESolution] <freq>
```

```
[ :SENSe ]:IM:BANDwidth|BWIDth[:RESolution]?
```

Set the resolution bandwidth that will be used for the Transmitter IM measurement mode. If span is set to a value greater than 5 MHz, minimum resolution bandwidth is limited to 1 kHz.

Factory Preset: Auto coupled.

Range: 100 Hz to 300.0 kHz

Default Unit: Hz

SENSe Subsystem

Remarks: You must be in the cdma2000, W-CDMA, or 1xEV-DO mode to use this command. Use INSTRument:SElect to set the mode.

Intermodulation—Resolution Bandwidth State

```
[ :SENSe ] :IM :BANDwidth | BWIDth [ :RESolution ] :AUTO OFF | ON | 0 | 1
```

```
[ :SENSe ] :IM :BANDwidth | BWIDth [ :RESolution ] :AUTO?
```

Select auto (default value) or manual (user entered value) to set the resolution bandwidth.

Factory Preset: ON

Remarks: You must be in the cdma2000, W-CDMA, or 1xEV-DO mode to use this command. Use INSTRument:SElect to set the mode.

Intermodulation—Root Raised Cosine Filter Alpha

```
[ :SENSe ] :IM :FILTeR [ :RRC ] :ALPHa <numeric>
```

```
[ :SENSe ] :IM :FILTeR [ :RRC ] :ALPHa?
```

Set the alpha value of the Root Raised Cosine (RRC) filter.

Factory Preset: 0.22

Range: 0.01 to 0.5

Remarks: You must be in the W-CDMA mode to use this command. Use INSTRument:SElect to set the mode.

Intermodulation—Root Raised Cosine Filter State

```
[ :SENSe ] :IM :FILTeR [ :RRC ] [ :STATe ] OFF | ON | 0 | 1
```

```
[ :SENSe ] :IM :FILTeR [ :RRC ] [ :STATe ]?
```

Turn the Root Raised Cosine (RRC) filter on or off.

Factory Preset: ON

Remarks: You must be in the W-CDMA mode to use this command. Use INSTRument:SElect to set the mode.

Intermodulation—Base Frequency Auto Search

```
[ :SENSe ] :IM :FREQuency :AUTO OFF | ON | 0 | 1
```

```
[ :SENSe ] :IM :FREQuency :AUTO?
```

Turn the base frequency auto search function on or off.

OFF – the frequencies set by the [:SENSe] :IM:FREQuency are used.

ON – automatically determined by searching the entire span.

Factory Preset: ON

Remarks: You must be in the cdma2000, W-CDMA, or 1xEV-DO mode to use this command. Use INSTRument:SElect to set the mode.

Intermodulation—Base Frequencies Delta

[:SENSe] :IM:FREQuency [:BASE] :DELta <freq>

[:SENSe] :IM:FREQuency [:BASE] :DELta?

Set the delta frequency which is (the base upper frequency – the base lower frequency).

Factory Preset: Auto coupled.

Range: E4406A
–4.3214 GHz to 4.3214 GHz

PSA
–3.0000 GHz to 3.0000 GHz

Default Unit: Hz

Remarks: Frequency step value is set by
[:SENSe] :FREQuency:CENTer:STEP [:INCRement]
You must be in the cdma2000, W-CDMA, or 1xEV-DO mode to use this command. Use INSTRument:SElect to set the mode.

Intermodulation—Base Lower Frequency

[:SENSe] :IM:FREQuency [:BASE] :LOWer <freq>

[:SENSe] :IM:FREQuency [:BASE] :LOWer?

Set the frequency value of the base lower frequency. The available lower limit value is dependent on the Resolution Bandwidth setting.

Factory Preset: Auto coupled.

Range: E4406A
1 kHz to 4.3214 GHz

PSA
1 kHz to 3.0 GHz

Default Unit: Hz

Remarks: Frequency step value is set by
[:SENSe] :FREQuency:CENTer:STEP [:INCRement]

SENSe Subsystem

You must be in the cdma2000, W-CDMA, or 1xEV-DO mode to use this command. Use INSTRUMENT:SELEct to set the mode.

Intermodulation—Base Upper Frequency

[:SENSe] :IM:FREQuency[:BASE] :UPPer <freq>

[:SENSe] :IM:FREQuency[:BASE] :UPPer?

Set the frequency value of the base upper frequency. The available lower limit value is dependent on the Resolution Bandwidth setting.

Factory Preset: Auto coupled.

Range: E4406A
1 kHz to 4.3214 GHz

PSA
1 kHz to 3.0 GHz

Default Unit: Hz

Remarks: Frequency step value is set by
[:SENSe] :FREQuency:CENTer:STEP[:INCRement]

You must be in the cdma2000, W-CDMA, or 1xEV-DO mode to use this command. Use INSTRUMENT:SELEct to set the mode.

Intermodulation—Span

[:SENSe] :IM:FREQuency:SPAN <freq>

[:SENSe] :IM:FREQuency:SPAN?

Set the span.

Factory Preset: 20.0 MHz for cdma2000, 1xEV-DO
50.0 MHz for W-CDMA

Range: 100.0 kHz to 100.0 MHz

Default Unit: Hz

Remarks: You must be in the cdma2000, W-CDMA, or 1xEV-DO mode to use this command. Use INSTRUMENT:SELEct to set the mode.

Intermodulation—Measurement Mode

[:SENSe] :IM:MODE AUTO | TWOTone | TXIM

[:SENSe] :IM:MODE?

Select the measurement mode of the intermodulation measurement.

AUTO – Automatically identifies the intermodulation caused by the two-tone or transmit intermodulation signals.

Two-tone (TWOTone)– Measures the two-tone intermodulation products.

Transmit (TXIM)– Measures the transmit intermodulation products.

Factory Preset: AUTO

Remarks: You must be in the cdma2000, W-CDMA, or 1xEV-DO mode to use this command. Use INSTRument:SElect to set the mode.

Intermodulation—Measurement Reference

[:SENSe] :IM:REfERENCE AUTO | AVERAge | LOWer | UPPer

[:SENSe] :IM:REfERENCE?

Select the measurement reference of the intermodulation measurement.

AUTO – Automatically sets the highest level signal in two base signals as measurement reference.

AVERAge – Sets the average level of the base lower carrier and upper carrier frequency as measurement reference.

LOWer – Sets the base lower carrier as measurement reference.

UPPer – Sets the base upper carrier as measurement reference.

Factory Preset: AUTO

Remarks: You must be in the cdma2000, W-CDMA, or 1xEV-DO mode to use this command. Use INSTRument:SElect to set the mode.

Multi Carrier Power Measurement

Commands for querying the multi carrier power measurement results and for setting to the default values are found in the “MEASure Group of Commands” on page 193. The equivalent front panel keys for the parameters described in the following commands, are found under the **Meas Setup** key, after the **Multi Carrier Power** measurement has been selected from the **MEASURE** key menu.

History: E4406A:
Added version A.04.00 and later

Multi Carrier Power—Average Count

[:SENSe] :MCPower :AVERAge :COUNT <integer>

[:SENSe] :MCPower :AVERAge :COUNT?

Set the number of data acquisitions that will be averaged. After the specified number of average counts, the average mode (termination control) setting determines the average action.

Factory Preset: 10

Range: 1 to 10,000

Remarks: You must be in the W-CDMA mode to use this command. Use INSTRument:SElect to set the mode.

Multi Carrier Power—Averaging State

[:SENSe] :MCPower :AVERAge [:STATE] OFF | ON | 0 | 1

[:SENSe] :MCPower :AVERAge [:STATE]?

Turn the averaging function On or Off.

Factory Preset: ON

Remarks: You must be in the W-CDMA mode to use this command. Use INSTRument:SElect to set the mode.

Multi Carrier Power—Averaging Termination Control

[:SENSe] :MCPower :AVERAge :TCONTRol EXPonential | REPEAT

[:SENSe] :MCPower :AVERAge :TCONTRol?

Select the type of termination control used for averaging. This determines the averaging action after the specified number of data acquisitions (average count) is reached.

EXPonential – Each successive data acquisition after the average count is reached, is exponentially weighted and combined with the existing average.

REPeat – After reaching the average count, the averaging is reset and a new average is started.

Factory Preset: REPeat

Remarks: You must be in the W-CDMA mode to use this command. Use INSTRUMENT:SElect to set the mode.

Multi Carrier Power—Root Raised Cosine Filter Alpha

[:SENSE] :MCPower :FILTer [:RRC] :ALPHa <numeric>

[:SENSE] :MCPower :FILTer [:RRC] :ALPHa?

Set the alpha value of the Root Raised Cosine (RRC) filter.

Factory Preset: 0.22

Range: 0.01 to 0.5

Remarks: You must be in the W-CDMA mode to use this command. Use INSTRUMENT:SElect to set the mode.

Multi Carrier Power—Root Raised Cosine Filter State

[:SENSE] :MCPower :FILTer [:RRC] [:STATe] OFF | ON | 0 | 1

[:SENSE] :MCPower :FILTer [:RRC] [:STATe] ?

Turn the Root Raised Cosine (RRC) filter on or off.

Factory Preset: ON

Remarks: You must be in the W-CDMA mode to use this command. Use INSTRUMENT:SElect to set the mode.

Multi Carrier Power—Base Frequencies Delta

[:SENSE] :MCPower :FREQuency [:BASE] :DELTA <freq>

[:SENSE] :MCPower :FREQuency [:BASE] :DELTA?

Set the delta frequency, the base upper frequency – the base lower frequency.

Factory Preset: 5 MHz

Range: –15 MHz, –10 MHz, –5 MHz, 5 MHz, 10 MHz, or 15 MHz

Default Unit: Hz

Remarks: You must be in the W-CDMA mode to use this command. Use INSTRUMENT:SElect to set the mode.

SENSE Subsystem

Multi Carrier Power—Offset Frequency Absolute Limit

```
[ :SENSE ] :MCPower :OFFSet :LIST :ABSolute  
<abs_power> , <abs_pwer> , <abs_pwer> , <abs_pwer>
```

```
[ :SENSE ] :MCPower :OFFSet :LIST :ABSolute?
```

Sets the absolute amplitude levels to test against for each of the custom offsets. The list must contain four (4) entries. If there is more than one offset, the offset closest to the carrier channel is the first one in the list.

[:SENSE] :MCPower :OFFSet :LIST :TEST selects the type of testing to be done at each offset.

The query returns four (4) real numbers that are the current absolute amplitude test limits.

Factory Preset:

Offset A	Offset B	Offset C	Offset D
50 dBm	50 dBm	50 dBm	50 dBm

Range: -200.0 to 50.0 dBm

Remarks: You must be in the W-CDMA mode to use this command. Use INSTRument:SElect to set the mode.

Multi Carrier Power—Offset Frequency Relative Limit to Carrier

```
[ :SENSE ] :MCPower :OFFSet :LIST :RCARrier  
<rel_power> , <rel_power> , <rel_power> , <rel_power>
```

```
[ :SENSE ] :MCPower :OFFSet :LIST :RCARrier?
```

Sets the amplitude levels to test against for any custom offsets. This amplitude level is relative to the carrier amplitude. If multiple offsets are available, the list contains four (4) entries. The offset closest to the carrier channel is the first one in the list. [:SENSE] :MCPower :OFFSet :LIST :TEST selects the type of testing to be done at each offset.

The query returns four (4) real numbers that are the current amplitude test limits, relative to the carrier, for each offset.

Factory Preset:

Offset A	Offset B	Offset C	Offset D
0 dB	0 dB	0 dB	0 dB

Range: -150.0 to 50.0 dB

Remarks: You must be in the W-CDMA mode to use this command. Use INSTRument:SElect to set the mode.

Multi Carrier Power—Offset Frequency Test Mode

**[:SENSe] :MCPower :OFFSet :LIST :TEST ABSolute | AND | OR | RELative ,
ABSolute | AND | OR | RELative , ABSolute | AND | OR | RELative ,
ABSolute | AND | OR | RELative**

[:SENSe] :MCPower :OFFSet :LIST :TEST?

Define the type of testing to be done at any custom offset frequencies. The measured powers are tested against the absolute values defined with [:SENSe]:MCPower:OFFSet[n]:LIST:ABSolute, or the relative values defined with [:SENSe]:MCPower:OFFSet[n]:LIST:RCARrierr.

The types of the testing that can be done for each offset include:

- **ABSolute** - Test the absolute power measurement. If it fails, then return a failure for the measurement at this offset.
- **AND** - Test both the absolute power measurement and the power relative to the carrier. If they both fail, then return a failure for the measurement at this offset.
- **OR** - Test both the absolute power measurement and the power relative to the carrier. If either one fails, then return a failure for the measurement at this offset.
- **RELative** - Test the power relative to the carrier. If it fails, then return a failure for the measurement at this offset.

Factory Preset:

Offset A	Offset B	Offset C	Offset D
REL	REL	REL	REL

Remarks: You must be in the W-CDMA mode to use this command. Use INSTRument:SELEct to set the mode.

Multi Carrier Power—Offset Selection

[:SENSe] :MCPower :OFFSet :SELEct ALL | TFS | TOI

[:SENSe] :MCPower :OFFSet :SELEct?

Select measurements on offsets.

ALL – All adjacent and alternate channels are measured include between two carriers.

Third, fifth, and seventh order intermodulation (TFS) – The third, fifth, and seventh order intermodulation parts are measured.

Third order intermodulation (TOI) – Only the third order Intermodulation part

SENSE Subsystem

is measured.

Factory Preset: All

Remarks: You must be in the W-CDMA mode to use this command. Use INSTRUMENT:SELEct to set the mode.

Multi Carrier Power—Measurement Reference

```
[ :SENSe ] :MCPower:REFErence AUTO|AVERAge|LOWer|UPPer
```

```
[ :SENSe ] :MCPower:REFErence?
```

Select the measurement reference of the multi carrier power measurement.

AUTO – Automatically sets the highest level signal in two base signals as measurement reference.

AVERAge – Sets the average level of the base lower carrier and upper carrier frequency as measurement reference.

LOWer – Sets the base lower carrier as measurement reference.

UPPer – Sets the base upper carrier as measurement reference.

Factory Preset: AUTO

Remarks: You must be in the W-CDMA mode to use this command. Use INSTRUMENT:SELEct to set the mode.

Occupied Bandwidth Measurement

Commands for querying the occupied bandwidth measurement results and for setting to the default values are found in the “MEASure Group of Commands” on [page 193](#). The equivalent front panel keys for the parameters described in the following commands, are found under the **Meas Setup** key, after the **Occupied BW** measurement has been selected from the **MEASURE** key menu.

Occupied Bandwidth—Average Count

```
[ :SENSe ] :OBW:AVERAge:COUNT <integer>
```

```
[ :SENSe ] :OBW:AVERAge:COUNT?
```

Set the number of data acquisitions that will be averaged. After the specified number of average counts, the average mode (termination control) setting determines the average action.

Factory Preset: 10

Range: 1 to 10,000

Remarks: This command is used for measurements in the MEASURE menu.

You must be in the PDC, cdma2000, W-CDMA, or 1xEV-DO mode to use this command. Use INSTRUMENT:SELEct to set the mode.

History: E4406A:
Version A.02.00 or later

Front Panel

Access: Meas Setup, Avg Number

Occupied Bandwidth—Averaging State

[:SENSE] :OBW:AVERAge [:STATe] OFF | ON | 0 | 1

[:SENSe] :OBW:AVERAge [:STATe] ?

Turn the averaging function on or off.

Factory Preset: ON

Remarks: You must be in the PDC, cdma2000, W-CDMA, or 1xEV-DO mode to use this command. Use INSTRUMENT:SELEct to set the mode.

History: E4406A:
Version A.02.00 or later

Front Panel

Access: Meas Setup, Avg Number

Occupied Bandwidth—Averaging Termination Control

[:SENSE] :OBW:AVERAge:TCONtrol EXPonential | REPEat

[:SENSe] :OBW:AVERAge:TCONtrol ?

Select the type of termination control used for the averaging function. This determines the averaging action after the specified number of data acquisitions (average count) is reached.

EXPonential - After the average count is reached, each successive data acquisition is exponentially weighted and combined with the existing average.

REPEat - After reaching the average count, the averaging is reset and a new average is started.

Factory Preset: EXPonential for PDC

REPEat for cdma2000, W-CDMA, 1xEV-DO

Remarks: You must be in the PDC, cdma2000, W-CDMA, or 1xEV-DO mode to use this command. Use INSTRUMENT:SELEct to set the mode.

SENSe Subsystem

History: E4406A:
Version A.02.00 or later

Front Panel
Access: **Meas Setup, Avg Mode**

Occupied Bandwidth—Resolution Bandwidth

[:SENSe] :OBW :BANDwidth | BWIDth [:RESolution] <freq>

[:SENSe] :OBW :BANDwidth | BWIDth [:RESolution] ?

Set the resolution bandwidth that will be used.

Factory Preset: 30.0 kHz

Range: 1.0 kHz to 1.0 MHz

Default Unit: Hz

Remarks: You must be in the cdma2000, W-CDMA, or 1xEV-DO mode to use this command. Use INSTRument:SElect to set the mode.

Occupied Bandwidth—FFT Window

[:SENSe] :OBW :FFT :WINDow [:TYPE]

BH4Tap | BLACkman | FLATtop | GAUSSian | HAMMing | HANNing | KB70 | KB90 | KB110 | UNIFORM

[:SENSe] :OBW :FFT :WINDow [:TYPE] ?

Select the FFT window type.

BH4Tap - Blackman Harris with 4 taps

BLACkman - Blackman

FLATtop - flat top, set to the default (for high amplitude accuracy)

GAUSSian - Gaussian with alpha of 3.5

HAMMing - Hamming

HANNing - Hanning

KB70, 90, and 110 - Kaiser Bessel with sidelobes at -70, -90, or -110 dBc

UNIFORM - no window is used. (This is the unity response.)

Factory Preset: GAUSSian

Remarks: You must be in the cdma2000, W-CDMA, or 1xEV-DO mode to use this command. Use INSTRument:SElect to set the mode.

Occupied Bandwidth—Span

```
[ :SENSe ] :OBW:FREQuency:SPAN <freq>
```

```
[ :SENSe ] :OBW:FREQuency:SPAN?
```

Set the occupied bandwidth span. The analyzer span will retain this value throughout the measurement.

Factory Preset: 10.0 MHz
3.75 MHz for cdma2000, 1xEV-DO

Range: 10.0 kHz to 10.0 MHz

Default Unit: Hz

Remarks: You must be in the PDC, cdma2000, W-CDMA, or 1xEV-DO mode to use this command. Use INSTRument:SELEct to set the mode.

Occupied Bandwidth—Percent of Total Power (E4406A only)

```
[ :SENSe ] :OBW:PERCent <number>
```

```
[ :SENSe ] :OBW:PERCent?
```

Set the percentage of the total power for which the occupied bandwidth is calculated.

Factory Preset: 99%

Range: 0.1% to 99.9%

Default Unit: percent

Remarks: You must be in the iDEN mode to use this command. Use INSTRument:SELEct to set the mode.

Front Panel

Access: Meas Setup, Occ BW % Pwr

Occupied Bandwidth—Trigger Source

iDEN mode (E4406A)

```
[ :SENSe ] :OBW:TRIGger:SOURce
```

```
EXTErnal[1] | EXTErnal2 | IF | IMMEDIATE | RFBURSt
```

```
[ :SENSe ] :OBW:TRIGger:SOURce?
```

PDC mode

```
[ :SENSe ] :OBW:TRIGger:SOURce
```

```
EXTErnal[1] | EXTErnal2 | IF | IMMEDIATE | RFBURSt
```

SENSe Subsystem

[:SENSe] :OBW:TRIGger:SOURce?

cdma2000, W-CDMA, 1xEV-DO mode

[:SENSe] :OBW:TRIGger:SOURce

EXTernal[1] | EXTernal2 | FRAMe | IF | IMMEDIATE | LINE | RFBurst

[:SENSe] :OBW:TRIGger:SOURce?

Select one of the trigger sources used to control the data acquisitions for the occupied bandwidth measurement.

EXTernal1 – rear panel external trigger input

EXTernal2 – front panel external trigger input

FRAMe – internal frame trigger (cdma2000, W-CDMA, 1xEV-DO mode only)

IF – internal IF envelope (video) trigger

IMMEDIATE – the next data acquisition is immediately taken, capturing the signal asynchronously (also called free run)

LINE – power line (cdma2000, W-CDMA, 1xEV-DO mode only)

RFBurst – wideband RF burst envelope trigger that has automatic level control for periodic burst signals

Factory Preset: IMMEDIATE for BS in PDC, cdma2000, W-CDMA, 1xEV-DO mode

RFBurst for MS in PDC, iDEN (E4406A) mode

RFBurst for iDEN (E4406A)

Remarks:

You must be in the PDC, iDEN (E4406A), cdmaOne, cdma2000, W-CDMA, or 1xEV-DO mode to use this command. Use INSTRUMENT:SELEct to set the mode.

History: E4406A:

Version A.02.00 or later

Output RF Spectrum Measurement

Commands for querying the output RF spectrum measurement results and for setting to the default values are found in the “[MEASure Group of Commands](#)” on [page 193](#). The equivalent front panel keys for the parameters described in the following commands, are found under the **Meas Setup** key, after the **GMSK Output RF Spectrum** measurement has been selected from the **MEASURE** key menu.

Output RF Spectrum—Number of Bursts Averaged

[:SENSe] :ORFSpectrum:AVERage:COUNT <integer>

[:SENSe] :ORFSpectrum:AVERAge:COUNT?

Set the number of bursts that will be averaged. For the output RF spectrum due to switching transients, it is more accurate to consider this the number of frames that are measured. After the specified number of bursts (average counts), the averaging mode (terminal control) setting determines the averaging action.

Factory Preset: 15

Range: 1 to 10,000

Remarks: You must be in the GSM, EDGE mode to use this command.
Use INSTRument:SElect to set the mode.

Output RF Spectrum—Fast Averaging

[:SENSe] :ORFSpectrum:AVERAge:FAST[:STATE] OFF|ON|0|1

[:SENSe] :ORFSpectrum:AVERAge:FAST[:STATE]?

Make the measurement faster by using an averaging technique different from that defined by the standard. A valid average can be obtained by measuring the power in half the normal number of bursts by using 50% - 90% of the burst, 10% - 50% of the burst and excluding the midamble.

This faster averaging is only done when averaging is on and only the modulation results are being measured. If both modulation and switching transients results are being measured, then the measurement uses the default averaging.

Factory Preset: ON

Remarks: You must be in the GSM, EDGE mode to use this command.
Use INSTRument:SElect to set the mode.

Output RF Spectrum—Averaging Type for Modulation Spectrum

[:SENSe] :ORFSpectrum:AVERAge:MODUlation:TYPE LOG|RMS

[:SENSe] :ORFSpectrum:AVERAge:MODUlation:TYPE?

Select the type of averaging for measuring the modulation spectrum. This is an advanced control that normally does not need to be changed. Setting this to a value other than the factory default, may cause invalid measurement results.

LOG - The log of the power is averaged. (This is also known as video averaging.)

RMS - The power is averaged, providing the rms of the voltage.

Factory Preset: LOG

Remarks: You must be in the GSM, EDGE mode to use this command.
Use INSTRument:SElect to set the mode.

SENSE Subsystem

Output RF Spectrum—Averaging Control

`[:SENSE] :ORFSpectrum:AVERage[:STATE] OFF | ON | 0 | 1`

`[:SENSE] :ORFSpectrum:AVERage[:STATE] ?`

Turn averaging on or off.

Factory Preset: ON

Remarks: You must be in the GSM, EDGE mode to use this command.
Use INSTRument:SELEct to set the mode.

Output RF Spectrum—Averaging Type for Switching Transient Spectrum Query

`[:SENSE] :ORFSpectrum:AVERage:SWITching:TYPE?`

Queries the type of averaging for measuring the switching transient spectrum.

Factory Preset: MAXP (maximum peak power)

Remarks: You must be in the GSM, EDGE mode to use this command.
Use INSTRument:SELEct to set the mode.

History: E4406A:
Query only format adopted for version A.05.00.

Output RF Spectrum—Resolution BW for the Modulation Spectrum at the Carrier

`[:SENSE] :ORFSpectrum:BANDwidth|BWIDth[:RESolution]
:MODulation:CARRier <freq>`

`[:SENSE] :ORFSpectrum:BANDwidth|BWIDth[:RESolution]
:MODulation:CARRier?`

Selects the resolution bandwidth for measuring the carrier when measuring spectrum due to modulation and wideband noise.

This parameter is only used with the Standard or Short lists, and not with the Custom list.

Factory Preset: 30 kHz

Range: 1 kHz to 5 MHz

Default Unit: Hz

Remarks: You must be in the GSM, EDGE mode to use this command.
Use INSTRument:SELEct to set the mode.

Output RF Spectrum—Resolution BW For Modulation At Close Offsets

```
[ :SENSe]:ORFSpectrum:BANDwidth|BWIDth[:RESolution]
:MODulation:OFFSet:CLOSe <freq>
```

```
[ :SENSe]:ORFSpectrum:BANDwidth|BWIDth[:RESolution]
:MODulation:OFFSet:CLOSe?
```

Set the resolution bandwidth used for the spectrum due to modulation part of the ORFS measurement for offset frequencies less than 1800 kHz.

This parameter is only used with the Standard or Short lists, and not with the Custom list.

Factory Preset: 30 kHz

Range: 1 kHz to 5 MHz

Default Unit: Hz

Remarks: You must be in the GSM, EDGE mode to use this command.
Use INSTRument:SElect to set the mode.

Output RF Spectrum—Resolution BW for Modulation at Far Offsets

```
[ :SENSe]:ORFSpectrum:BANDwidth|BWIDth[:RESolution]
:MODulation:OFFSet:FAR <freq>
```

```
[ :SENSe]:ORFSpectrum:BANDwidth|BWIDth[:RESolution]
:MODulation:OFFSet:FAR?
```

Set the resolution bandwidth used for the spectrum due to modulation part of the ORFS measurement for offset frequencies greater than or equal to 1800 kHz.

For E4406A this parameter is only used with the Standard or Short lists, and not with the Custom list.

Factory Preset: 100 kHz

Range: 1 kHz to 5 MHz

Default Unit: Hz

Remarks: You must be in the GSM, EDGE mode to use this command.
Use INSTRument:SElect to set the mode.

Output RF Spectrum—Resolution BW for the Switching Transient Spectrum at the Carrier

```
[ :SENSe]:ORFSpectrum:BANDwidth|BWIDth[:RESolution]
:SWITching:CARRier <freq>
```

```
[ :SENSe]:ORFSpectrum:BANDwidth|BWIDth[:RESolution]
:SWITching:CARRier?
```

SENSE Subsystem

Selects the resolution bandwidth for the carrier when measuring spectrum due to switching transients.

This parameter is only used with the Standard or Short lists, and not with the Custom list.

Factory Preset: 300 kHz

Range: 1 kHz to 5 MHz

Default Unit: Hz

Remarks: You must be in the GSM, EDGE mode to use this command.
Use INSTRUMENT:SELEct to set the mode.

Output RF Spectrum—Resolution BW For Switching Transients At Close Offsets

```
[ :SENSE ] :ORFSpectrum:BANDwidth|BWIDth[:RESolution]  
:SWITching:OFFSet:CLOSe <freq>
```

```
[ :SENSE ] :ORFSpectrum:BANDwidth|BWIDth[:RESolution]  
:SWITching:OFFSet:CLOSe?
```

Set the resolution bandwidth used for the spectrum due to switching transients part of the ORFS measurement for offset frequencies less than 1800 kHz.

This parameter is only used with the Standard or Short lists, and not with the Custom list.

Factory Preset: 30 kHz

Range: 1 kHz to 5 MHz

Default Unit: Hz

Remarks: You must be in the GSM, EDGE mode to use this command.
Use INSTRUMENT:SELEct to set the mode.

Output RF Spectrum—Resolution BW For Switching Transients At Far Offsets

```
[ :SENSE ] :ORFSpectrum:BANDwidth|BWIDth[:RESolution]  
:SWITching:OFFSet:FAR <freq>
```

```
[ :SENSE ] :ORFSpectrum:BANDwidth|BWIDth[:RESolution]  
:SWITching:OFFSet:FAR?
```

Set the resolution bandwidth used for the spectrum due to switching transients part of the ORFS measurement for offset frequencies greater than or equal to 1800 kHz.

This parameter is only used with the standard or short lists, and not with the custom list.

Factory Preset: 30 kHz
 Range: 1 kHz to 5 MHz
 Default Unit: Hz
 Remarks: You must be in the GSM, EDGE mode to use this command.
 Use INSTRument:SElect to set the mode.

Output RF Spectrum—Break Frequency

[:SENSe]:ORFSpectrum:BFrequency <freq>

[:SENSe]:ORFSpectrum:BFrequency?

Set the direct time break frequency. An FFT measurement method is used for offsets below this break frequency. The direct time measurement method is used for offsets above the break frequency. See the chapter on making measurements for more information about these two methods.

Factory Preset: 600 kHz
 Range: 0 kHz to 775 kHz
 Default Unit: Hz
 History: E4406A:
 Added revision A.04.00 and later
 Remarks: You must be in the GSM, EDGE mode to use this command.
 Use INSTRument:SElect to set the mode.

Front Panel
 Access: **Meas Setup, Advanced, Direct Time Break Freq**

Output RF Spectrum—Define Custom Modulation Resolution Bandwidth List

**[:SENSe]:ORFSpectrum:LIST:MODulation:BWIDth|BWIDth
 <res bw>{,<res bw>}**

[:SENSe]:ORFSpectrum:LIST:MODulation:BWIDth|BWIDth?

Define the custom set of resolution bandwidths for the modulation spectrum part of the ORFS measurement. The first bandwidth specified is for the carrier. Each resolution bandwidth in this list corresponds to an offset frequency in the modulation offset frequency list. The number of items in each of these lists needs to be the same.

Factory Preset: Same as standard list
 Range: 1 kHz to 5 MHz
 Default Unit: Hz

SENSe Subsystem

Remarks: This command is only valid if SENS:ORFS:MEAS is set to multiple and the custom list type is selected with SENS:ORFS:LIST:SEL CUST.

You must be in the GSM, EDGE mode to use this command.
Use INSTRUMENT:SELEct to set the mode.

Output RF Spectrum—Define Custom Modulation Offset Frequency List

```
[ :SENSe ]:ORFSpectrum:LIST:MODulation[:FREQUENCY]  
<offset freq>{,<offset freq>}
```

```
[ :SENSe ]:ORFSpectrum:LIST:MODulation[:FREQUENCY]?
```

Define the custom set of offset frequencies at which the modulation spectrum part of the ORFS measurement will be made. The first offset specified must be 0 Hz for the carrier. For each offset frequency specified, the power will be measured at both the lower and upper offsets. Up to 14 (+ the 0 Hz carrier frequency) offset frequencies may be defined.

Factory Preset: Same as standard list

Range: 10 kHz to 10 MHz

Default Unit: Hz

Remarks: This command is only valid if SENS:ORFS:MEAS is set to multiple and the custom list type is selected with SENS:ORFS:LIST:SEL CUST.

You must be in the GSM, EDGE mode to use this command.
Use INSTRUMENT:SELEct to set the mode.

Output RF Spectrum—Define Custom Modulation Level Offsets

```
[ :SENSe ]:ORFSpectrum:LIST:MODulation:LOFFset  
<level>{,<level>}
```

```
[ :SENSe ]:ORFSpectrum:LIST:MODulation:LOFFset?
```

Define the custom set of level offsets for the modulation spectrum part of the ORFS measurement. This allows you to modify the standard limits by adding a delta amplitude value to them. The first level offset specified must be 0 dB for the carrier. Each level offset in this list corresponds to an offset frequency in the modulation offset frequency list. The number of items in each of these lists needs to be the same.

Example: `ORFS:LIST:MOD:FREQ 0,300e3,1.3e6,2.0e6`

Sets custom offset freqs: 300 kHz, 1.3 MHz, 2 MHz

`ORFS:LIST:MOD:BAND 30e3,30e3,30e3,100e3`

Sets corresponding RBWs: 30 kHz, 30 kHz, 100 kHz

```
ORFS:LIST:MOD:loffset 0,-5,3,5
```

Assume the power level of the signal is -43 dBm, then the standard limits for these three offsets are: -42 dBc, -72 dBc, -75 dBc respectively. The loffset command adjusts these limits to: -47 (-42-5) dBc, -70 (-73+3) dBc, -70 (-75+5) dBc.

Factory Preset: 0 dB level offsets (limits remain the same as the standards)

Range: 0 to 50 dB

Default Unit: dB

Remarks: This command is only valid if SENS:ORFS:MEAS is set to multiple and the custom list type is selected with SENS:ORFS:LIST:SEL CUST.

You must be in the GSM, EDGE mode to use this command. Use INSTRUMENT:SElect to set the mode.

History: E4406A:
Version A.03.00 or later

Output RF Spectrum—Offset Frequency List

```
[ :SENSe ]:ORFSpectrum:LIST:SElect CUSTom | SHORt | STANdard
```

```
[ :SENSe ]:ORFSpectrum:LIST:SElect?
```

Select the list of settings that will be used to make the ORFS measurement. This specifies standard or customized lists and short lists. The lists contain the offset frequencies (and bandwidths) that are used for the modulation spectrum and transient spectrum parts of the ORFS measurement.

CUSTom - uses the four user-defined lists that specify:

- Offset frequencies for modulation spectrum measurement
- Corresponding resolution bandwidths for each of the modulation offset frequencies
- Offset frequencies for switching transient spectrum measurement
- Corresponding resolution bandwidths for each of the switching transient offset frequencies

SHORt - a shortened list of the offset frequencies specified in the GSM Standards. It uses two internal offset frequency lists, one for modulation spectrum and the other for switching transient spectrum. These offset frequencies cannot be changed, but the resolution bandwidths can be changed by other commands in the SENSe:ORFSpectrum subsystem.

STANdard - the complete list of the offset frequencies specified in the GSM Standards, except for those offsets greater than 6 MHz. It uses two internal offset frequency lists, one for modulation spectrum and the other for switching

SENSe Subsystem

transient spectrum. These offset frequencies cannot be changed, but the resolution bandwidths can be changed by other commands in the SENS:ORFSpectrum subsystem.

Factory Preset: SHORT

Remarks: This command is only valid if SENS:ORFS:MEAS is set to multiple.

If you change the number of custom offsets then the number of offset bandwidths, frequencies and level offsets must also be changed.

You must be in the GSM, EDGE mode to use this command. Use INSTRUMENT:SElect to set the mode.

Output RF Spectrum—Define Custom Switching Transient Resolution Bandwidth List

```
[ :SENSe ] :ORFSpectrum:LIST:SWITching:BANDwidth|BWIDth  
<res_bw>{ ,<res_bw> }
```

```
[ :SENSe ] :ORFSpectrum:LIST:SWITching:BANDwidth|BWIDth?
```

Define the custom set of resolution bandwidths for the switching transient spectrum part of the ORFS measurement. The first bandwidth specified is for the carrier. Each resolution bandwidth in this list corresponds to an offset frequency in the switching transient offset frequency list. The number of items in each of these lists needs to be the same.

Factory Preset: Same as standard list

Range: 1 kHz to 5 MHz

Default Unit: Hz

Remarks: This command is only valid if SENS:ORFS:MEAS is set to multiple and the custom list type is selected with SENS:ORFS:LIST:SEL CUST.

You must be in GSM, EDGE mode to use this command. Use INSTRUMENT:SElect to set the mode.

Output RF Spectrum—Define Custom Switching Transient Offset Frequency List

```
[ :SENSe ] :ORFSpectrum:LIST:SWITching[ :FREQUENCY ]  
<offset_freq>{ ,<offset_freq> }
```

```
[ :SENSe ] :ORFSpectrum:LIST:SWITching[ :FREQUENCY ]?
```

Define the custom set of offset frequencies at which the switching transient spectrum part of the ORFS measurement will be made. The first offset specified

must be 0 Hz, for the carrier. For each offset frequency specified, the power will be measured at both the lower and upper offsets. Up to 14 (+ the 0 Hz carrier frequency) offset frequencies may be defined.

Factory Preset: Same as standard list

Range: 10 kHz to 10 MHz

Default Unit: Hz

Remarks: This command is only valid if SENS:ORFS:MEAS is set to multiple and the custom list type is selected with SENS:ORFS:LIST:SEL CUST.

You must be in the GSM, EDGE mode to use this command. Use INSTRUMENT:SELEct to set the mode.

Output RF Spectrum—Define Custom Switching Transient Level Offsets

```
[ :SENSe ]:ORFSpectrum:LIST:SWITChing:LOFFset
<level>{ ,<level> }
```

```
[ :SENSe ]:ORFSpectrum:LIST:SWITChing:LOFFset?
```

Define the custom set of level offsets for the switching transient spectrum part of the ORFS measurement. This allows you to modify the standard limits by adding a delta amplitude value to them. The first level offset specified must be 0 dB for the carrier. Each level offset in this list corresponds to an offset frequency in the modulation offset frequency list. The number of items in each of these lists needs to be the same.

Example: See the ORFS:LIST:MOD:LOFF example above.

Factory Preset: 0 dB level offsets (limits remain the same as the standards)

Range: 0 to 50 dB

Default Unit: dB

Remarks: This command is only valid if SENS:ORFS:MEAS is set to multiple and the custom list type is selected with SENS:ORFS:LIST:SEL CUST.

You must be in GSM, EDGE mode to use this command. Use INSTRUMENT:SELEct to set the mode.

History: E4406A:
Version A.03.00 or later

Output RF Spectrum—Measure Offsets Measurement Method

```
[ :SENSe ]:ORFSpectrum:MEASure MULTiple|SINGLE
```

```
[ :SENSe ]:ORFSpectrum:MEASure?
```

SENSe Subsystem

Select the measurement method to be used.

MULTiple - the measurement is done at all offsets in the offset frequency list.

SINGLE - the measurement is done at only one offset as determined by the offset frequency setting. This allows detailed examination of the time-domain waveform at the specified offset frequency.

Factory Preset: **MULTiple**

Remarks: You must be in the GSM, EDGE mode to use this command.
Use **INSTrument:SELEct** to set the mode.

Output RF Spectrum—Offset Frequency

[:SENSe] :ORFSpectrum:OFRequency <freq>

[:SENSe] :ORFSpectrum:OFRequency?

Set the offset frequency that is used to measure a single offset. This command is only valid if **SENS:ORFS:MEAS** is set to single.

Factory Preset: **250 kHz**

Range: **-12.0 MHz to +12.0 MHz, step size: steps through the values in the selected offset frequency list.**

Default Unit: **Hz**

Remarks: You must be in the GSM, EDGE mode to use this command.
Use **INSTrument:SELEct** to set the mode.

Output RF Spectrum—Trigger Source

**[:SENSe] :ORFSpectrum:TRIGger:SOURce
EXTErnal[1] | EXTErnal2 | FRAME | IMMEDIATE | RFBURst**

[:SENSe] :ORFSpectrum:TRIGger:SOURce?

Select the trigger source used to control the data acquisitions.

EXTErnal 1 - front panel external trigger input

EXTErnal 2 - rear panel external trigger input

FRAME - uses the internal frame timer, which has been synchronized to the selected burst sync

IMMEDIATE - the next data acquisition is immediately taken, capturing the signal asynchronously (also called free run)

RFBURst - wideband RF burst envelope trigger that has automatic level control for periodic burst signals

Factory Preset: **RFBURst** if the RF Burst Hardware (option B7E) has been

installed

EXTERNAL if option B7E has not been installed

Remarks: You must be in the GSM, EDGE mode to use this command.
Use INSTRUMENT:SELECT to set the mode.

Output RF Spectrum—Measurement Type

```
[ :SENSE ]:ORFSpectrum:TYPE
MODulation|MSWitching|SWITching|FFModulation
```

```
[ :SENSE ]:ORFSpectrum:TYPE?
```

Select the measurement type.

MODulation - only the modulation spectrum is measured.

MSWitching (Modulation & Switching) - both modulation and switching transient spectrums are measured.

SWITching - only the switching transient spectrum is measured.

FFModulation- full frame modulation improves measurement speed by acquiring a full frame of data prior to performing the FFT calculation. FFT modulation can only be used if all slots in the transmitted frame are active.

Factory Preset: MODulation

Remarks: You must be in the GSM, EDGE mode to use this command.
Use INSTRUMENT:SELECT to set the mode.

History: Added in version A.05.00

Output RF Spectrum—Select Modulation Method

```
[ :SENSE ]:ORFSpectrum:TYPE:MODulation[:METHOD]
DISCcrete|SWEEp
```

```
[ :SENSE ]:ORFSpectrum:TYPE:MODulation[:METHOD]?
```

Selects discrete or sweep modulation method.

Discrete - Measures RF output spectrum at preset frequency offsets. Results are returned in tabular form.

Sweep - Measures output RF spectrum from -1.8 MHz to +1.8 MHz offset in approximately 10 kHz steps. Results are returned as a trace.

Remarks: You must be in the EDGE(w/GSM) mode to use this command.
Use INSTRUMENT:SELECT to set the mode.

History: E4406A:
Version A.05.00

Power Control Measurement

Commands for querying the power control results are found in the “MEASure Group of Commands” on page 193.

Power Control—Resolution Bandwidth

```
[ :SENSE ] :PCONTrol :BANDwidth | BWIDth [ :RESolution ] <freq>
```

```
[ :SENSE ] :PCONTrol :BANDwidth | BWIDth [ :RESolution ] ?
```

Set the resolution BW.

Factory Preset: 5.0 MHz

Range: 1.0 MHz to 10 MHz if RBW filter type = FLATtop

100.0 kHz to 8 MHz if RBW filter type = GAUSSian

Remarks: You must be in the W-CDMA mode to use this command. Use INSTRument:SElect to set the mode.

Power Control—RBW Filter Type

```
[ :SENSE ] :PCONTrol :BANDwidth | BWIDth [ :RESolution ] :TYPE  
FLATtop | GAUSSian
```

```
[ :SENSE ] :PCONTrol :BANDwidth | BWIDth [ :RESolution ] :TYPE ?
```

Set the resolution BW filter type.

Factory Preset: FLATtop

Remarks: You must be in the W-CDMA mode to use this command. Use INSTRument:SElect to set the mode.

Power Control—Data Capture Length

```
[ :SENSE ] :PCONTrol :CAPTure :TIME <float>
```

```
[ :SENSE ] :PCONTrol :CAPTure :TIME ?
```

Set Capture Interval for Power Control Measurement.

Factory Preset: 4.0 frames

Range: 1.0, 2.0, 4.0, or 8.0

The number between two settable values is rounded to the nearest value.

Remarks: You must be in the W-CDMA mode to use this command. Use INSTRument:SElect to set the mode.

Power Control—Chip Rate

```
[ :SENSe ]:PCONtrol:CRATe <float>
```

```
[ :SENSe ]:PCONtrol:CRATe?
```

Set the chip rate.

Factory Preset: 3.84 MHz

Range: 3.456 MHz to 4.224 MHz

Remarks: You must be in the W-CDMA mode to use this command. Use INSTRument:SElect to set the mode.

Power Control—Root Raised Cosine Alpha

```
[ :SENSe ]:PCONtrol:FILTer[ :RRC]:ALPHa <float>
```

```
[ :SENSe ]:PCONtrol:FILTer[ :RRC]:ALPHa?
```

Set the alpha (roll-off factor) to the Root Raised Cosine (RRC) filter.

Factory Preset: 0.22

Range: 0.01 to 0.5

Remarks: You must be in the W-CDMA mode to use this command. Use INSTRument:SElect to set the mode.

Power Control—Root Raised Cosine Filter Control

```
[ :SENSe ]:PCONtrol:FILTer[ :RRC][ :STATE] OFF|ON|0|1
```

```
[ :SENSe ]:PCONtrol:FILTer[ :RRC][ :STATE]?
```

Turn Root Raised Cosine Filter On or Off.

Factory Preset: Off

Remarks: You must be in the W-CDMA mode to use this command. Use INSTRument:SElect to set the mode.

Power Control—Measurement Data Type

```
[ :SENSe ]:PCONtrol:METHod WAVEform|CPOWer
```

```
[ :SENSe ]:PCONtrol:METHod?
```

Set Power Control Acquisition method to Waveform or Chip Power.

WAVEform - Measure and perform power calculation based on waveform (raw data of A/D).

CPOWer - Measure and perform power calculation based on chip power

SENSE Subsystem

(resample on chip clock).

Factory Preset: WAVEform

Remarks: You must be in the W-CDMA mode to use this command. Use INSTRument:SElect to set the mode.

Power Control—PRACH Preamble Signature

[:SENSE] : PCONtrol : PRACH : SIGNature <integer>

[:SENSE] : PCONtrol : PRACH : SIGNature ?

Set Signature number for PRACH Preamble detection, when [:SENSE] : PCONtrol : PRACH : SIGNature : AUTO is set to OFF. This value is set at its auto number if PRACH Preamble Signature Auto mode is set to ON.

Factory Preset: 0

Range: 0 to 15

Remarks: You must be in the W-CDMA mode to use this command. Use INSTRument:SElect to set the mode.

Power Control—PRACH Preamble Signature Detection

[:SENSE] : PCONtrol : PRACH : SIGNature : AUTO OFF | ON | 0 | 1

[:SENSE] : PCONtrol : PRACH : SIGNature : AUTO ?

Set Signature Auto mode ON for PRACH Preamble detection.

Factory Preset: ON

Remarks: You must be in the W-CDMA mode to use this command. Use INSTRument:SElect to set the mode.

Power Control—Slot Format for MS

[:SENSE] : PCONtrol : SLOT : FORMat SF0 | SF1 | SF2 | SF3 | SF4 | SF5

[:SENSE] : PCONtrol : SLOT : FORMat ?

Select Slot Format from SF0 to SF5 for Slot Power Measurement.

SF0 – Slot Format 0

SF1 – Slot Format 1

SF2 – Slot Format 2

SF3 – Slot Format 3

SF4 – Slot Format 4

SF5 – Slot Format 5

Factory Preset: SF0

Remarks: You must be in the W-CDMA mode to use this command. Use INSTRUMENT:SELEct to set the mode.

Power Control—Scramble Code Up Link

[:SENSe] : PCONtrol : SYNC : SCRamble <integer>

[:SENSe] : PCONtrol : SYNC : SCRamble?

Set the Scramble code for uplink synchronization.

Factory Preset: 0x0

Range: 0 to 16,777,215 (0x0 to 0xFFFFFFFF; 24 bits)

Remarks: You must be in the W-CDMA mode to use this command. Use INSTRUMENT:SELEct to set the mode.

Power Control—Trigger Source

[:SENSe] : PCONtrol : TRIGer : SOURce

EXtErnal[1] | EXtErnal2 | FRAMe | IF | IMMEdiate | RFBurst | LINE

[:SENSe] : PCONtrol : TRIGer : SOURce?

Select the trigger source used to control the data acquisitions.

EXtErnal[1] – Front Panel External Trigger Input.

EXtErnal2 – Rear Panel External Trigger Input.

IMMEdiate – the next data acquisition is immediately taken, capturing the signal asynchronously (also called Free Run).

RFBurst – internal wideband RF burst envelope trigger that has automatic level control for periodic burst signals.

IF – internal IF Envelope trigger.

FRAMe – internal Frame trigger.

LINE – Power line.

Factory Preset: IMMEdiate

Remarks: You must be in the W-CDMA mode to use this command. Use INSTRUMENT:SELEct to set the mode.

SENSE Subsystem

Power Control—Measurement Type

`[:SENSE] :PCONTrol :TYPE SLOT | PRACH`

`[:SENSE] :PCONTrol :TYPE?`

Set Power Control Measurement Type to Slot Measurement or PRACH measurement. The sync type is automatically set either to DPCCH (for slot measurement) or to PRACH preamble (for PRACH measurement).

SLOT - Slot oriented power calculation will be performed

PRACH - PRACH oriented power calculation will be performed

Factory Preset: SLOT

Remarks: You must be in the W-CDMA mode to use this command. Use INSTRUMENT:SElect to set the mode.

Phase & Frequency Error Measurement

Commands for querying the phase and frequency error measurement results and for setting to the default values are found in the “MEASure Group of Commands” on page 193. The equivalent front panel keys for the parameters described in the following commands, are found under the **Meas Setup** key, after the **GMSK Phase & Freq** measurement has been selected from the **MEASURE** key menu.

Phase & Frequency Error—Number Of Bursts Averaged

[:SENSe] :PFError :AVERage :COUNT <integer>

[:SENSe] :PFError :AVERage :COUNT?

Set the number of bursts that will be averaged. After the specified number of bursts (average counts), the averaging mode (terminal control) setting determines the averaging action.

Factory Preset: 15

Range: 1 to 1,000

Remarks: You must be in the GSM, EDGE mode to use this command.
Use INSTRument:SElect to set the mode.

Phase & Frequency Error—Averaging State

[:SENSe] :PFError :AVERage [:STATe] OFF | ON | 0 | 1

[:SENSe] :PFError :AVERage [:STATe]?

Turn averaging on or off.

Factory Preset: OFF

Remarks: You must be in the GSM, EDGE mode to use this command.
Use INSTRument:SElect to set the mode.

Phase & Frequency Error—Averaging Mode

[:SENSe] :PFError :AVERage :TCONtrol EXPonential | REPeat

[:SENSe] :PFError :AVERage :TCONtrol?

Select the type of termination control used for the averaging function. This determines the averaging action after the specified number of bursts (average count) is reached.

EXPonential - Each successive data acquisition after the average count is reached, is exponentially weighted and combined with the existing average.

REPeat - After reaching the average count, the averaging is reset and a new average is started.

SENSe Subsystem

Factory Preset: REPeat

Remarks: You must be in the GSM, EDGE mode to use this command.
Use INSTRument:SElect to set the mode.

Phase & Frequency Error—Averaging Type

[:SENSe] :PFERror :AVERage :TYPE MEAN | MAXimum

[:SENSe] :PFERror :AVERage :TYPE?

Select the type of averaging:

MEAN - the scalar results are averaged.

MAXimum - the maximum scalar results are retained.

Factory Preset: MAXimum.

Remarks: For E4406A you must be in the GSM mode to use this command. Use INSTRument:SElect to set the mode.

Phase & Frequency Error—I/Q Origin Offset Measurement

[:SENSe] :PFERror :IQOFFset [:STATE] OFF | ON | 0 | 1

[:SENSe] :PFERror :IQOFFset [:STATE]?

Turn On or Off I/Q origin offset measurement. If it is set to On, I/Q origin offset is performed. When it is set to Off, the measurement is not performed, but the measurement speed is improved.

Factory Preset: On

On - I/Q origin offset measurement is performed.

Off - I/Q origin offset measurement is not performed.

Remarks: You must be in the GSM, EDGE mode to use this command.
Use INSTRument:SElect to set the mode.

Phase & Frequency Error—Burst Synchronization

**[:SENSe] :PFERror :BSYNc :SOURCE
EXTernal [1] | EXTernal2 | NONE | RFBurst | TSEQUence**

[:SENSe] :PFERror :BSYNc :SOURCE?

Select the method of synchronizing the measurement to the GSM bursts.

EXTernal 1 - burst sync at front panel external trigger input

EXTernal 2 - burst sync at rear panel external trigger input

Training Sequence (TSEquence) - the training sequence burst sync performs a demodulation of the burst and determines the start and stop of the useful part of the burst based on the midamble training sequence.

RFBurst - the RF amplitude burst sync approximates the start and stop of the useful part of the burst without demodulation of the burst.

None - no burst synchronization is used

Factory Preset: TSEquence

Remarks: You must be in the GSM, EDGE mode to use this command.
Use INSTRUMENT:SElect to set the mode.

Phase & Frequency Error—Trace Data

[:SENSe] :PFError:TRACe [:STATe] OFF | ON | 0 | 1

[:SENSe] :PFError:TRACe [:STATe] ?

Turn On or Off trace data for phase and frequency error measurement. If it is set to On, the trace data is available. When it is set to Off, the trace data is not available, but the measurement speed is improved.

Factory Preset: On

On - Trace data is available.

Off - Trace data is not available.

Remarks: You must be in the GSM, EDGE mode to use this command.
Use INSTRUMENT:SElect to set the mode.

Phase & Frequency Error—Trigger Source

[:SENSe] :PFError:TRIGger:SOURCE
EXtErnal [1] | EXtErnal2 | FRAMe | IF | IMMEdiate | RFBurst

[:SENSe] :PFError:TRIGger:SOURCE ?

Select the trigger source used to control the data acquisitions.

EXtErnal 1 - front panel external trigger input.

EXtErnal 2 - rear panel external trigger input.

FRAMe - uses the internal frame timer, which has been synchronized to the selected burst sync.

IF - internal IF envelope (video) trigger.

IMMEdiate - the next data acquisition is immediately taken, capturing the signal asynchronously (also called free run).

RFBurst - wideband RF burst envelope trigger that has automatic level control

SENSe Subsystem

for periodic burst signals.

Factory Preset: RFBurst

Remarks: You must be in the GSM, EDGE mode to use this command.
Use INSTRument:SElect to set the mode.

Select I/Q Power Range (E4406A only)

```
[ :SENSe ] :POWer :IQ :RANGe [ :UPPer ] <Float 64> { DBM | DBMV | W
```

```
[ :SENSe ] :POWer :IQ :RANGe [ :UPPer ] ?
```

Selects maximum total power expected from unit under test at test port when I or Q port is selected.

Range: For 50 Ohms:

13.0, 7.0, 1.0, -5.1 [DBM]
60.0, 54.0, 48.0, 41.9 [DBMV]
.02, .005, .0013, .00031 [W]

For 600 Ohms:

2.2, -3.8, -9.8, -15.8 [DBM]
60.0, 54.0, 48.0, 41.9 [DBMV]
.0017, .00042, .0001, .000026 [W]

Values for 1 M Ohm vary according to selected reference impedance.

Remarks: Implemented for BASIC and W-CDMA modes.

History: Version A.05.00 or later

Select I/Q Voltage Range (E4406A only)

```
[ :SENSe ] :VOLTagE :IQ :RANGe [ :UPPer ] <Float 64> [ V ]
```

```
[ :SENSe ] :VOLTagE :IQ :RANGe [ :UPPer ] ?
```

Selects upper voltage range when I or Q port is selected. This setting helps set the gain which is generated in the variable gain block of the BbIQ board to improve dynamic range.

Range: 1.0, 0.5, .025, 0.125[V]

Remarks: Implemented for BASIC and W-CDMA modes.

History: Version A.05.00 or later

RF Power Commands

RF Port Input Attenuation

```
[ :SENSe]:POWer[:RF]:ATTenuation <rel_power>
```

```
[ :SENSe]:POWer[:RF]:ATTenuation?
```

Set the RF input attenuator. This value is set at its auto value if RF input attenuation is set to auto.

Factory Preset: 0 dB
12 dB for iDEN (E4406A)

Range: 0 to 40 dB

Default Unit: dB

Front Panel

Access: **Input, Input Atten**

Internal RF Preamplifier Control

```
[ :SENSe]:POWer[:RF]:GAIN[:STATe] OFF|ON|0|1
```

```
[ :SENSe]:POWer[:RF]:GAIN[:STATe]?
```

Turns the internal preamp on or off for the currently selected measurement.

Factory Preset: OFF

Internal RF Preamplifier Attenuation

```
[ :SENSe]:POWer[:RF]:GAIN:ATTenuation <rel_power>
```

```
[ :SENSe]:POWer[:RF]:GAIN:ATTenuation?
```

Specifies the internal mechanical attenuator setting when the internal preamp is on. Requires Option 1DS. This not the same attenuator used when the preamp is OFF.

Factory Preset: 0 [dB]

Front Panel

Access: **Input/Output, More (1 of 2), Int Preamp for Optional Personalities.**
AMPLITUDE/Y Scale, More (1 of 3), Int Preamp for SA mode

Range: 0,10, or 20 [dB]
Other numbers between 0 and 20 are rounded to the nearest number; entries between numbers are rounded up. Entries above 20 are rounded down to 20.

SENSe Subsystem

Remarks: You must be in W-CDMA, cdma2000, or 1xEV-DO mode with the preamp ON to use this command. Use INSTRument:SElect to set the mode. BEFORE you can turn on the preamp using the :SENSe command, you must also send the following command: CONFigure:RHO|EVMQpsk|CDPower.

Key Path: Input/Output, More (1 of 2), Attenuation

State Saved: Saved in Instrument State

RF Port Power Range Auto

```
[ :SENSe ] :POWer [ :RF ] :RANGe :AUTO OFF | ON | 0 | 1
```

```
[ :SENSe ] :POWer [ :RF ] :RANGe :AUTO?
```

Select the RF port power range to be set either automatically or manually.

ON - power range is automatically set as determined by the actual measured power level at the start of a measurement.

OFF - power range is manually set

Factory Preset: ON

Remarks: You must be in the cdmaOne, GSM, EDGE, NADC, PDC, cdma2000, W-CDMA, mode to use this command. Use INSTRument:SElect to set the mode.

Front Panel

Access: **Input, Max Total Pwr (at UUT)**

RF Port Power Range Maximum Total Power

```
[ :SENSe ] :POWer [ :RF ] :RANGe [ :UPPer ] <power>
```

```
[ :SENSe ] :POWer [ :RF ] :RANGe [ :UPPer ] ?
```

Set the maximum expected total power level at the radio unit under test. This value is ignored if RF port power range is set to auto. External attenuation required above 30 dBm.

Factory Preset: -15.0 dBm

Range: -100.0 to 80.0 dBm for EDGE, GSM
-100.0 to 27.7 dBm for cdmaOne, iDEN (E4406A)
-200.0 to 50.0 dBm for NADC, PDC
-200.0 to 100.0 dBm for cdma2000, W-CDMA

Default Unit: dBm

Remarks: Global to the current mode. This is coupled to the RF input

attenuation

For E4406A you must be in the Service, cdmaOne, EDGE(w/GSM), GSM, iDEN, NADC, PDC, cdma2000, or W-CDMA mode to use this command. Use INSTRument:SElect to set the mode.

Front Panel

Access:

Input, Max Total Pwr (at UUT)

Power Statistics CCDF Measurement

Commands for querying the statistical power measurement of the complementary cumulative distribution function (CCDF) measurement results and for setting to the default values are found in the “MEASURE Group of Commands” on page 193. The equivalent front panel keys for the parameters described in the following commands, are found under the **Meas Setup** key, after the **Power Stat CCDF** measurement has been selected from the **MEASURE** key menu.

History: E4406A:
Added PStatistic to Basic Mode version A.04.00

Power Statistics CCDF—Channel Bandwidth

[:SENSE] :PStatistic: BANDwidth | BWIDth <freq>

[:SENSE] :PStatistic: BANDwidth | BWIDth ?

Enter a frequency value to set the channel bandwidth that will be used for data acquisition.

Factory Preset: 5.0 MHz

Range: 10.0 kHz to 6.7 MHz

Default Unit: Hz

Remarks: You must be in the Basic (E4406A), cdma2000, W-CDMA, or 1xEV-DO mode to use this command. Use INSTRUMENT:SELEct to set the mode.

Power Statistics CCDF—Sample Counts

[:SENSE] :PStatistic: COUNTs <integer>

[:SENSE] :PStatistic: COUNTs ?

Enter a value to set the sample counts. Measurement stops when the sample counts reach this value.

Factory Preset: 10,000,000

Range: 1,000 to 2,000,000,000

Unit: counts

Remarks: You must be in the Basic (E4406A), cdma2000, W-CDMA, or 1xEV-DO mode to use this command. Use INSTRUMENT:SELEct to set the mode.

Power Statistics CCDF—Sweep Time

[:SENSE] :PStatistic: SWEEp: TIME <time>

[:SENSe]:PStatistic:SWEep:TIME?

Enter a value to set the measurement interval that will be used to make measurements.

Factory Preset: 1.0 ms

Range: 0.1 ms to 10 ms

Remarks: You must be in the Basic, cdma2000, W-CDMA, or 1xEV-DO mode to use this command. Use INSTRument:SELEct to set the mode.

Power Statistics CCDF—Trigger Source**[:SENSe]:PStatistic:TRIGger:SOURce**

EXTernal[1] | EXTernal2 | FRAME | IF | IMMEDIATE | RFBurst

[:SENSe]:PStatistic:TRIGger:SOURce?

Select one of the trigger sources used to control the data acquisitions.

EXTernal 1 - front panel external trigger input

EXTernal 2 - rear panel external trigger input

FRAMe - uses the internal frame timer, which has been synchronized to the selected burst sync.

IF - internal IF envelope (video) trigger

IMMEDIATE - the next data acquisition is immediately taken, capturing the signal asynchronously (also called Free Run).

RFBurst - wideband RF burst envelope trigger that has automatic level control for periodic burst signals.

Factory Preset: IMMEDIATE

Remarks: You must be in the Basic (E4406A), cdma2000, W-CDMA, or 1xEV-DO mode to use this command. Use INSTRument:SELEct to set the mode.

Power vs. Time Measurement

Commands for querying the power versus time measurement results and for setting to the default values are found in the [“MEASure Group of Commands” on page 193](#). The equivalent front panel keys for the parameters described in the following commands, are found under the **Meas Setup** key, after the **Power vs Time** measurement has been selected from the **MEASURE** key menu.

SENSE Subsystem

Power vs. Time—Average Count

[:SENSE] :PVTime:AVERage:COUNT <integer>

[:SENSE] :PVTime:AVERage:COUNT?

Set the number of data acquisitions that will be averaged.

Factory Preset: 40 for W-CDMA

Range: 1 to 10,000

Remarks: You must be in the W-CDMA mode to use this command. Use INSTRument:SElect to set the mode.

Power vs. Time—Number of Bursts Averaged

[:SENSE] :PVTime:AVERage:COUNT <integer>

[:SENSE] :PVTime:AVERage:COUNT?

Set the number of bursts that will be averaged. After the specified number of bursts (average counts), the averaging mode (terminal control) setting determines the averaging action.

Factory Preset: 15
100 for 1xEV-DO

Range: 1 to 10,000

Remarks: For E4406A you must be in the EDGE(w/GSM), GSM, 1xEV-DO, or Service mode to use this command. Use INSTRument:SElect to set the mode.

Power vs. Time—Averaging State

[:SENSE] :PVTime:AVERage[:STATe] OFF|ON|0|1

[:SENSE] :PVTime:AVERage[:STATe]?

Turn averaging on or off.

Factory Preset: OFF
ON for 1xEV-DO, W-CDMA

Remarks: For E4406A you must be in the EDGE(w/GSM), GSM, 1xEV-DO, W-CDMA, or Service mode to use this command. Use INSTRument:SElect to set the mode.

Power vs. Time—Averaging Mode

```
[ :SENSe ]:PVTime:AVERAge:TCONtrol EXPonential|REPeat
```

```
[ :SENSe ]:PVTime:AVERAge:TCONtrol?
```

Select the type of termination control used for the averaging function. This specifies the averaging action after the specified number of bursts (average count) is reached.

EXPonential - Each successive data acquisition after the average count is reached is exponentially weighted and combined with the existing average.

REPeat - After reaching the average count, the averaging is reset and a new average is started.

Factory Preset: EXPonential

REPeat for 1xEV-DO, W-CDMA

Remarks: For E4406A you must be in the EDGE(w/GSM), GSM, 1xEV-DO, W-CDMA, or Service mode to use this command. Use INSTRument:SElect to set the mode.

Power vs. Time—Averaging Type

EDGE (w/GSM), GSM, Service mode

```
[ :SENSe ]:PVTime:AVERAge:TYPE
LOG|MAXimum|MINimum|MXMinimum|RMS
```

1xEV-DO mode

```
[ :SENSe ]:PVTime:AVERAge:TYPE
LOG|MAXimum|MINimum|MXMinimum|RMS|SCALar
```

W-CDMA mode

```
[ :SENSe ]:PVTime:AVERAge:TYPE RMS|MAXimum|MINimum
```

```
[ :SENSe ]:PVTime:AVERAge:TYPE?
```

Select the type of averaging to be performed.

LOG - The log of the power is averaged. (This is also known as video averaging.)

MAXimum - The maximum values are retained.

MINimum - The minimum values are retained.

MXMinimum - Both the maximum and the minimum values are retained. (E4406A - EDGE(W/GSM), GSM, and Service modes, and PSA - only)

RMS - The power is averaged to provide a voltage rms value.

SCALar - The amplitude level of power is averaged to provide a voltage value.

SENSe Subsystem

(1xEV-DO mode only)

Factory Preset: RMS

Remarks: For E4406A you must be in the EDGE(w/GSM), GSM, 1xEV-DO, W-CDMA, or Service mode to use this command. Use INSTRument:SElect to set the mode.

Power vs. Time—Resolution BW

[[:SENSe]:PVTime:BANDwidth|BWIDth[:RESolution] <freq>

[[:SENSe]:PVTime:BANDwidth|BWIDth[:RESolution]?

Set the resolution bandwidth. This is an advanced control that normally does not need to be changed. Setting this to a value other than the factory default, may cause invalid measurement results.

Factory Preset: 1.5 MHz

5.0 MHz for W-CDMA

Range: 1 kHz to 5 MHz

1.0 kHz to 10.0 MHz when PVT:BAND:RES:TYPE is set to FLATtop

1.0 kHz to 8.0 MHz when PVT:BAND:RES:TYPE is set to GAUSSian

Default Unit: Hz

Remarks: For E4406A you must be in the EDGE(w/GSM), GSM, Service, 1xEV-DO, or W-CDMA mode to use this command. Use INSTRument:SElect to set the mode.

Power vs. Time—RBW Filter Type

[[:SENSe]:PVTime:BANDwidth|BWIDth[:RESolution]:TYPE

FLATtop|GAUSSian

[[:SENSe]:PVTime:BANDwidth|BWIDth[:RESolution]:TYPE?

Select the type of resolution bandwidth filter. This is an advanced control that normally does not need to be changed. Setting this to a value other than the factory default, may cause invalid measurement results.

FLATtop - a filter with a flat amplitude response, which provides the best amplitude accuracy.

GAUSSian - a filter with Gaussian characteristics, which provides the best pulse response.

Factory Preset: GAUSSian

FLAT_{top} for 1xEV-DO, W-CDMA

Remarks: For E4406A you must be in the EDGE(w/GSM), GSM, Service, 1xEV-DO, or W-CDMA mode to use this command. Use INSTRUMENT:SElect to set the mode.

For PSA you must be in the GSM, EDGE, 1xEV-DO, or W-CDMA mode to use this command. Use INSTRUMENT:SElect to set the mode.

Power vs. Time—Burst Synchronization Source

[:SENSE] :PVTIME :BSYNC :SOURCE RFBurst | TSEQUENCE

[:SENSE] :PVTIME :BSYNC :SOURCE?

Select the method of synchronizing the measurement to the GSM bursts.

RFBurst - the RF burst sync approximates the start and stop of the useful part of the burst without digital demodulation of the burst.

Training Sequence (TSEQUENCE) - the training sequence burst sync performs a demodulation of the burst and determines the start and stop of the useful part of the burst based on the midamble training sequence.

Factory Preset: RFBurst

Remarks: You must be in the GSM, EDGE mode to use this command. Use INSTRUMENT:SElect to set the mode.

Power vs. Time—Burst Search Threshold

[:SENSE] :PVTIME :BURST :STHRESHOLD <rel_power>

[:SENSE] :PVTIME :BURST :STHRESHOLD?

Specify the relative power threshold level to search for bursts. Use the commands SENSE:PVTIME:BURST:SLOPE and SENSE:PVTIME:BURST:SLOPE:INTEGRATION:TIME with this command.

Factory Preset: -10.00 dB

-45 dB for W-CDMA

Range: -100 to 0 dB

Remarks: You must be in the 1xEV-DO or W-CDMA mode to use this command. Use INSTRUMENT:SElect to set the mode.

History: PSA:
Added in version A.02.00

E4406A:
Added in version A.05.00

SENSe Subsystem

Power vs. Time—Burst Search Slope

[:SENSe] :PVTime:BURSt:SLOPe <number>

[:SENSe] :PVTime:BURSt:SLOPe?

Specify the minimum slope in the relative power level change per μs , to search for bursts at the specified threshold level.

Factory Preset: 2.0 dB/ μs

Range: 0.1 to 10.0 dB/ μs

Resolution: 0.1 dB/ μs

Remarks: You must be in the 1xEV-DO mode to use this command. Use INSTRument:SElect to set the mode.

History: PSA:
Added in version A.02.00
E4406A:
Added in version A.05.00

Power vs. Time—Burst Search Slope Time

[:SENSe] :PVTime:BURSt:SLOPe:INTEgration:TIME <number>

[:SENSe] :PVTime:BURSt:SLOPe:INTEgration:TIME?

Specify the integration time in the number of chips, to calculate the minimum slope to search for bursts at the specified threshold level.

Factory Preset: 2.0 chip

Range: 0.5 to 3.0 chip

Resolution: 0.1 chip

Remarks: You must be in the 1xEV-DO mode to use this command. Use INSTRument:SElect to set the mode.

History: PSA:
Added in version A.02.00
E4406A:
Added in version A.05.00

Power vs. Time—Chip Rate

[:SENSe] :PVTime:CRATe <float>

[:SENSe] :PVTime:CRATe?

Set the chip rate.

Factory Preset: 3.84 MHz

Range: 3.456 MHz to 4.224 MHz

Remarks: You must be in the W-CDMA mode to use this command. Use INSTRUMENT:SElect to set the mode.

Power vs. Time—Root Raised Cosine Filter Alpha

```
[ :SENSE ]:PVTime:FILTer[ :RRC ]:ALPHa <float>
```

```
[ :SENSE ]:PVTime:FILTer[ :RRC ]:ALPHa?
```

Set the alpha of RRC filter.

Factory Preset: 0.22

Range: 0.01 to 0.5

Remarks: You must be in the W-CDMA mode to use this command. Use INSTRUMENT:SElect to set the mode.

Power vs. Time—Root Raised Cosine Filter Control

```
[ :SENSE ]:PVTime:FILTer[ :RRC ][ :STATE ] 0|1|OFF|ON
```

```
[ :SENSE ]:PVTime:FILTer[ :RRC ][ :STATE ]?
```

Turn RRC filter On or Off.

Factory Preset: OFF

Remarks: You must be in the W-CDMA mode to use this command. Use INSTRUMENT:SElect to set the mode.

Power vs. Time—Limit Mask Display

```
[ :SENSE ]:PVTime:LIMit:MASK OFF|ON|0|1
```

```
[ :SENSE ]:PVTime:LIMit:MASK?
```

Show or hide the limit mask. Does not affect the pass/fail calculation for limit tests.

Factory Preset: ON

Remarks: You must be in GSM, EDGE, 1xEV-DO, or W-CDMA mode to use this command. Use INSTRUMENT:SElect to set the mode.

SENSe Subsystem

Power vs. Time—Lower Active Slot Mask Relative Level

```
[ :SENSe ] :PVTime:MASK:ASLot:LOWer:RELative <rel_power>
```

```
[ :SENSe ] :PVTime:MASK:ASLot:LOWer:RELative?
```

Enter the relative power level in the lower limit mask for the active slot.

Factory Preset: -2.5 dB

Range: -100 to +200 dB relative to the reference power

Default Unit: dB

Remarks: You must be in 1xEV-DO mode to use this command. Use INSTRument:SElect to set the mode.

History: PSA:
Added in version A.02.00

E4406A:
Added in version A.05.00

Power vs. Time—Active Slot Mask Lower Limit Test Mode

```
[ :SENSe ] :PVTime:MASK:ASLot:LOWer:TEST RELative|NONE
```

```
[ :SENSe ] :PVTime:MASK:ASLot:LOWer:TEST?
```

Set the mask to the lower limit test mode relative to the reference power.

Factory Preset: RELative

Range: Only RELative is currently available for the active slot.

Remarks: You must be in 1xEV-DO mode to use this command. Use INSTRument:SElect to set the mode.

History: PSA:
Added in version A.02.00

E4406A:
Added in version A.05.00

Power vs. Time—Active Slot Mask Time Interval

```
[ :SENSe ] :PVTime:MASK:ASLot:SWEep:TIME <time>
```

```
[ :SENSe ] :PVTime:MASK:ASLot:SWEep:TIME?
```

Define the time interval for active slot mask.

Factory Preset: 833.33 μ s

Range: -10 ms to +10 ms

Resolution: 10.0 ns

Remarks: You must be in 1xEV-DO mode to use this command. Use INSTRUMENT:SElect to set the mode.

History: PSA:
Added in version A.02.00

E4406A:
Added in version A.05.00

Power vs. Time—Active Slot Mask Upper Limit Test Mode

[:SENSe] :PVTime :MASK :ASLot :UPPer :TEST RELative |NONE

[:SENSe] :PVTime :MASK :ASLot :UPPer :TEST?

Set the mask to the upper limit test mode relative to the reference power.

Factory Preset: RELative

Range: Only RELative is currently available for the active slot mask.

Remarks: You must be in 1xEV-DO mode to use this command. Use INSTRUMENT:SElect to set the mode.

History: PSA:
Added in version A.02.00

E4406A:
Added in version A.05.00

Power vs. Time—Upper Active Slot Mask Relative Level

[:SENSe] :PVTime :MASK :ASLot :UPPer :RELative <rel_power>

[:SENSe] :PVTime :MASK :ASLot :UPPer :RELative?

Enter the relative power level in the upper limit mask for the active slot.

Factory Preset: 2.5 dB

Range: -100 to +200 dB relative to the reference power

Default Unit: dB

Remarks: You must be in 1xEV-DO mode to use this command. Use INSTRUMENT:SElect to set the mode.

History: PSA:
Added in version A.02.00

E4406A:
Added in version A.05.00

SENSe Subsystem

Power vs. Time—Lower Mask Absolute Amplitude Levels

```
[ :SENSe ] :PVTime:MASK:LIST:LOWer:ABSolute <power>, <power>, <power>, <power>, <power>
```

```
[ :SENSe ] :PVTime:MASK:LIST:LOWer:ABSolute?
```

Enter a power level for any of your mask line segments that require an absolute minimum power limit in addition to its relative limit. Each time a measurement is made the Ref Level is determined. (This is the power level of the useful part of the burst, or midway between the upper/lower masks). Remember, as the power of the Ref Level changes, all of the relative mask power levels will change by the same amount.

Each relative limit is then compared to the Ref Level and an equivalent absolute power level is calculated. This power level is compared to the specified absolute limit for each line segment. If this calculated relative limit is lower than the absolute limit you've specified, then the value of the absolute limit is used for this segment. Therefore, if the absolute limit is set to a very low value (–200 dBm), the calculated value of the reference limit will never be lower, and the specified relative limit will always be used for that segment. See [Figure 0-5 on page 470](#).

Every time point you defined with PVT:MASK:LOW:TIME must have a power value defined in the same order. You can put a comma in the SCPI command as a place holder for any points where an absolute power is not specified, and that segment will then use the default value.

Factory Preset: Selected GSM standard
Range: –200 dBm to +100 dBm
Default Unit: dBm
Remarks: You must be in GSM, EDGE mode to use this command. Use INSTRument:SElect to set the mode.
History: E4406A:
Added in revised A.03.00 and later

Power vs. Time—Lower Mask Points

```
[ :SENSe ] :PVTime:MASK:LIST:LOWer:POINTs?
```

Query the number of elements in the lower mask. This value is determined by the number of time points entered using

```
[ :SENSe ] :PVTime:MASK:LIST:LOWer:TIME.
```

Range: Integer, 1 to 25
Remarks: You must be in GSM, EDGE mode to use this command. Use INSTRument:SElect to set the mode.
History: E4406A:
Added in revision A.03.00

Power vs. Time—Lower Mask Relative Amplitude Levels

```
[ :SENSe ]:PVTime:MASK:LIST:LOWer:RELative <rel_power>,
<rel_power>, <rel_power>, <rel_power>
```

```
[ :SENSe ]:PVTime:MASK:LIST:LOWer:RELative?
```

Enter the relative power level for each horizontal line segment in the lower limit mask. There should be a power level for each time point entered using [:SENSe]:PVTime:MASK:LIST:LOWer:TIME, and they must be entered in the same order. These power levels are all relative to the defined Reference Power Level (the average power in the useful part of the data). When an upper and lower limit masks have been defined, the Reference Power Level is the mid-point between these two limits at time t0.

Any portion of the signal that has no limit line segment defined for it, will default to a very low limit (–100 dB relative to the reference power). This will keep the measurement from indicating a failure for that portion of the data.

Factory Preset: Selected GSM standard

–100.0, –100.0, –2.5, –100.0, and –100.0 dB for 1xEV-DO

–100.0, –100.0, –1.0, –100.0, and –100.0 dB for W-CDMA

Range: –100.0 to 200 dB relative to the reference power

Default Unit: dB

Remarks: You must be in GSM, EDGE, 1xEV-DO, or W-CDMA mode to use this command. Use INSTRument:SElect to set the mode.

History: E4406A:
Added in revision A.03.00

Power vs. Time—Mask Lower Limit Test Mode

```
[ :SENSe ]:PVTime:MASK:LIST:LOWer:TEST RELative|NONE,
,RELative|NONE, RELative|NONE, RELative|NONE
```

```
[ :SENSe ]:PVTime:MASK:LIST:LOWer:TEST?
```

Set the mask to the lower limit test mode.

Factory Preset: NONE, NONE, RELative, NONE, NONE

Range: Only RELative is currently available.

Remarks: You must be in 1xEV-DO or W-CDMA mode to use this command. Use INSTRument:SElect to set the mode.

History: PSA:
Added in version A.02.00

SENSe Subsystem

E4406A:
Added in version A.05.00

Power vs. Time—Lower Mask Time Points

```
[ :SENSe ] :PVTime:MASK:LIST:LOWER:TIME <seconds>{ , <seconds> }
```

```
[ :SENSe ] :PVTime:MASK:LIST:LOWER:TIME?
```

Enter the time points that define the horizontal line segments of the lower limit. A reference point designated “ t_0 ” is at the center of the useful data (usually the center of the burst). Each line segment to the right of the t_0 reference point is designated as a positive time value and each segment to the left of t_0 is a negative time value.

First enter positive values in sequence starting from t_0 , then negative values in sequence starting from t_0 . See [Figure 0-5 on page 470](#) and the

PVT:MASK:LIST:UPPER:TIME example below it. (This is an upper mask example, but they work the same.)

We recommend that you select a large time value for your first and last mask points (e.g. -1 and +1 second). This guarantees that you’ve defined a limit for all the measured data. (See Mask Segments 4 and 9 in the [Table on page 470](#) for an example.

Factory Preset: Selected GSM standard

Range: -1s to +1s, referenced to t_0 at the center of the useful data (burst center)

1 to 25 time points in a mask

Default Unit: seconds

Remarks: You must be in GSM, EDGE mode to use this command. Use INSTRUMENT:SELEct to set the mode.

History: E4406A:
Added in revision A.03.00

Power vs. Time—Mask Power Reference

```
[ :SENSe ] :PVTime:MASK:LIST:PREFerence A|B|C|D|E
```

```
[ :SENSe ] :PVTime:MASK:LIST:PREFerence?
```

Select the power reference from one of region (A, B, C, D or E).

Factory Preset: C

Remarks: Only one of regions can be On. If multiple regions are set On, the first On is set and returns error. You must be in W-CDMA mode to use this command. Use INSTRUMENT:SELEct to set the

mode.

Power vs. Time—Mask Interval

```
[ :SENSE ]:PVTime:MASK:LIST:SWEep:TIME <seconds>{, <seconds>}
```

```
[ :SENSE ]:PVTime:MASK:LIST:SWEep:TIME?
```

Define the mask interval.

Factory Preset: 642.0 μ s, 50.0 μ s, 1283.0 μ s, 50.0 μ s, 642.0 μ s

Range: -10 to 10 ms

Remarks: You must be in W-CDMA mode to use this command. Use INSTRUMENT:SELEct to set the mode.

Power vs. Time—Mask Offset

```
[ :SENSE ]:PVTime:MASK:LIST:TIME <seconds>{, <seconds>}
```

```
[ :SENSE ]:PVTime:MASK:LIST:TIME?
```

Define the mask start points.

Factory Preset: -667.0 μ s, -25.0 μ s, 25.0 μ s, 1308.0 μ s, 1358.0 μ s

Range: -10 to 10 ms

Remarks: You must be in W-CDMA mode to use this command. Use INSTRUMENT:SELEct to set the mode.

Power vs. Time—Mask Power Reference

```
[ :SENSE ]:PVTime:MASK:PREFErence A|B|C|D|E
```

```
[ :SENSE ]:PVTime:MASK:PREFErence?
```

Select one of the regions to be used as the power reference. If a region is selected, the power in that region is computed and used as the reference power.

Factory Preset: C

Range: A, B, C, D, or E

Remarks: You must be in 1xEV-DO mode to use this command. Use INSTRUMENT:SELEct to set the mode.

History: PSA:
Added in version A.02.00
E4406A:
Added in version A.05.00

SENSe Subsystem

Power vs. Time—Mask Interval

```
[ :SENSe ]:PVTime:MASK:LIST:SWEep:TIME <time>, <time>, <time>, <time>, <time>
```

```
[ :SENSe ]:PVTime:MASK:LIST:SWEep:TIME?
```

Specify the time interval values of the limit mask.

Factory Preset: 319.34, 7.00, 180.66, 7.00, and 319.34 μ s

Range: -10 ms to +10 ms

Default Unit: seconds

Remarks: You must be in 1xEV-DO mode to use this command. Use INSTRument:SElect to set the mode.

History: PSA:
Added in version A.02.00
E4406A:
Added in version A.05.00

Power vs. Time—Mask Time

```
[ :SENSe ]:PVTime:MASK:LIST:TIME <time>, <time>, <time>, <time>, <time>
```

```
[ :SENSe ]:PVTime:MASK:LIST:TIME?
```

Specify the starting time points of the limit mask.

Factory Preset: -416.67, -97.33, -90.33, 90.33, and 97.33 μ s

Range: -10 ms to +10 ms

Default Unit: seconds

Remarks: You must be in 1xEV-DO mode to use this command. Use INSTRument:SElect to set the mode.

History: PSA:
Added in version A.02.00
E4406A:
Added in version A.05.00

Power vs. Time—Upper Mask Absolute Amplitude Levels

```
[ :SENSe ]:PVTime:MASK:LIST:UPPER:ABSolute <power>, <power>, <power>, <power>, <power>
```

[:SENSe]:PVTime:MASK:LIST:UPPer:ABSolute?

Enter a power level for any of your mask line segments that require an absolute minimum power limit in addition to its relative limit. Each time a measurement is made the Ref Level is determined. (This is the power level of the useful part of the burst, or midway between the upper/lower masks). Remember, as the power of the Ref Level changes, all of the relative mask power levels will change by the same amount.

Each relative limit is then compared to the Ref Level and an equivalent absolute power level is calculated. This power level is compared to the specified absolute limit for each line segment. If this calculated relative limit is lower than the absolute limit you've specified, then the value of the absolute limit is used for this segment. Therefore, if the absolute limit is set to a very low value (–200 dBm), the calculated value of the reference limit will never be lower, and the specified relative limit will always be used for that segment. See [Figure 0-5 on page 470](#).

Every time point you defined with PVT:MASK:LOW:TIME must have a power value defined in the same order. You can put a comma in the SCPI command as a place holder for any points where an absolute power is not specified, and that segment will then use the default value.

Example: **PVT:MASK:LIST:UPP:ABS -200, -200, -58, -200, -200, -200, -200, -58, -200**

Factory Preset: Selected GSM standard

Range: –200 dBm to +100 dBm

Default Unit: dBm

Remarks: You must be in GSM, EDGE mode to use this command. Use INSTRUMENT:SELEct to set the mode.

History: E4406A:
Added in revision A.03.00

Power vs. Time—Upper Mask Points**[:SENSe]:PVTime:MASK:LIST:UPPer:POINTs?**

Query the number of elements in the upper mask. This value is determined by the number of time points entered using

[:SENSe]:PVTime:MASK:LIST:UPPer:TIME.

Range: integer, 1 to 25

Remarks: You must be in GSM, EDGE mode to use this command. Use INSTRUMENT:SELEct to set the mode.

History: E4406A:
Added in revision A.03.00

SENSe Subsystem

Power vs. Time—Upper Mask Relative Amplitude Levels

```
[ :SENSe ] :PVTime :MASK :LIST :UPPer :RELative <rel_power>,
<rel_power>, <rel_power>, <rel_power>
```

```
[ :SENSe ] :PVTime :MASK :LIST :UPPer :RELative?
```

Enter the relative power level for each horizontal line segment in the upper limit mask. There should be a power level for each time point entered using `[:SENSe] :PVTime :MASK :LIST :UPPer :TIME`, and they must be entered in the same order. These power levels are all relative to the defined Reference Power Level (the average power in the useful part of the data). When an upper and lower limit masks have been defined, the Reference Power Level is the mid-point between these two limits at time t_0 . See [Figure 0-5 on page 470](#).

Figure 0-5 Custom Upper Limit Mask Example

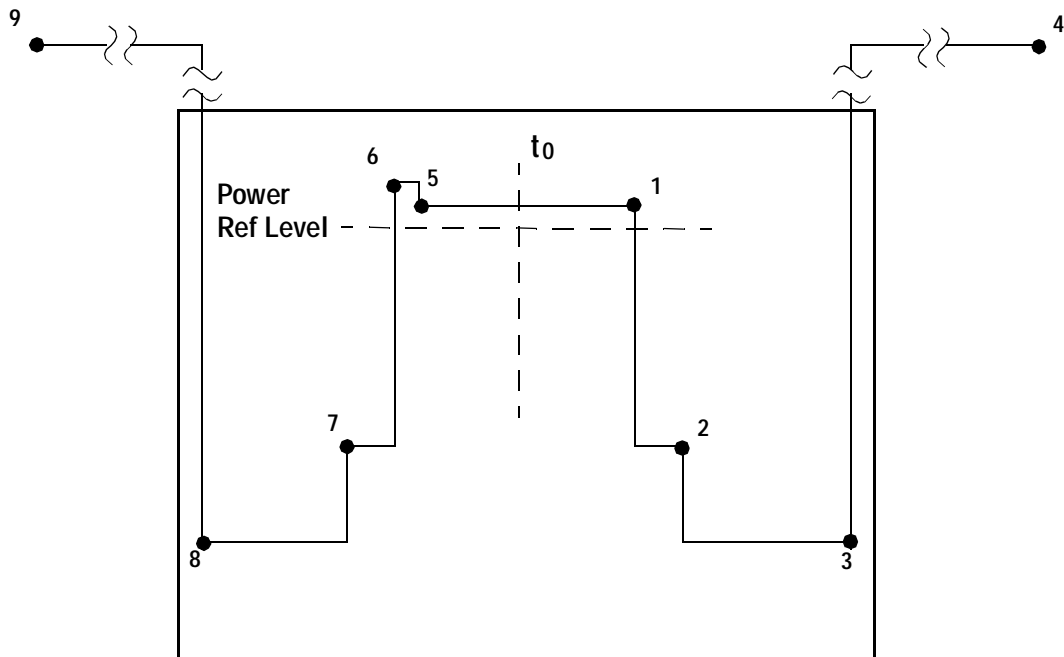

Entered Value for each Time Segment	Absolute Time Value	Relative Power (example with Ref Level = -12 dBm)		Entered Absolute Power (dBm)	Segment Number
		Entered Relative Power	Equivalent Absolute Power		
280.0e-6	280 μ s	+4 dBc	-8 dBm	-200 dBm	1
15.0e-6	295 μ s	-32 dBc	-44 dBm	-200 dBm	2
450.0e-6	745 μ s	-48 dBc	-60 dBm ^a	-58 dBm ^a	3

Entered Value for each Time Segment	Absolute Time Value	Relative Power (example with Ref Level = -12 dBm)		Entered Absolute Power (dBm)	Segment Number
		Entered Relative Power	Equivalent Absolute Power		
1	>1 sec	+100 dBc	+112 dBm	-200 dBm	4
-270.0e-6	-270 μ s	+4 dBc	-8 dBm	-200 dBm	5
-10.0e-6	-280 μ s	+7 dBc	-5 dBm	-200 dBm	6
-20.0e-6	-300 μ s	-25 dBc	-37 dBm	-200 dBm	7
-450e-6	-750 μ s	-43 dBc	-55 dBm	-58 dBm	8
-1	<-1 sec	+100 dBc	+112 dBm	-200 dBm	9

- a. Notice that this segment, with this value of Ref Level, has a calculated relative level of -60 dBm. This is lower than the specified absolute level of -58 dBm, so the -58 dBm value will be used as the test limit for the segment.

Example: **PVT:MASK:LIST:UPP:REL**
4,-32,-48,100,4,7,-25,-43,100

Factory Preset: Selected GSM standard
-7.0, 2.5, 2.5, 2.5, and 7.5 dB for 1xEV-DO
-40.0 dB, 2.0 dB, 1.0 dB, 2.0 dB, -40.0 dB for W-CDMA

Range: -100 to +200 dB relative to the reference power

Default Unit: dB

Remarks: You must be in GSM, EDGE, 1xEV-DO, or W-CDMA mode to use this command. Use INSTRUMENT:SElect to set the mode.

History: E4406A:
Added in revision A.03.00

Power vs. Time—Mask Upper Limit Test Mode

[:SENSe]:PVTtime:MASK:LIST:UPPer:TEST RELative|NONE,
RELative|NONE, RELative|NONE, RELative|NONE, RELative|NONE

[:SENSe]:PVTtime:MASK:LIST:UPPer:TEST?

Set to the upper limit test mode.

Factory Preset: RELative, RELative, RELative, RELative, RELative

Range: Only RELative is currently available.

Remarks: You must be in 1xEV-DO or W-CDMA mode to use this

SENSe Subsystem

command. Use INSTRument:SElect to set the mode.

History: PSA:
Added in version A.02.00
E4406A:
Added in version A.05.00

Power vs. Time—Upper Mask Time Points

```
[ :SENSe ]:PVTime:MASK:LIST:UPPer:TIME <seconds>, <seconds>,  
<seconds>, <seconds>, <seconds>
```

```
[ :SENSe ]:PVTime:MASK:LIST:UPPer:TIME?
```

Enter the time points that define the horizontal line segments of the upper limit. A reference point designated “ t_0 ” is at the center of the useful data (usually the center of the burst). Each line segment to the right of the t_0 reference point is designated as a positive time value and each segment to the left of t_0 is a negative time value.

First enter positive values in sequence starting from t_0 , then the negative values in sequence starting from t_0 . See [Figure 0-5 on page 470](#) and the PVTime:MASK:LIST:UPPer:TIME example below it.

We recommend that you select a large time value for your first and last mask points (e.g. -1 and +1 second). This guarantees that you’ve defined a limit for all the measured data. (See Mask Segments 4 and 9 in the table [Table on page 470](#) for an example.

Example: PVTime:MASK:LIST:UPPer:TIME 280e-6, 15e-6,
450e-6, 1, -270e-6, -10e-6, -20e-6, -450e-6, -1

Factory Preset: Selected GSM standard

Range: -1s to +1s, referenced to t_0 at the center of the useful data (burst center)

1 to 25 time points in a mask

Default Unit: seconds

Remarks: You must be in GSM, EDGE mode to use this command. Use INSTRument:SElect to set the mode.

History: E4406A:
Added in revision A.03.00

Power vs. Time—Mask Reference Point

```
[ :SENSe ]:PVTime:MASK:REFeRence TRIGger |RISE |CENTer
```

```
[ :SENSe ]:PVTime:MASK:REFeRence?
```

Define the reference point of the mask timing.

TRIGger - Set to the trigger point.

RISE - Set to the rising edge of the burst determined after acquisition process.

CENTer - Set to the center between the rising and falling edges of the burst determined after acquisition process

Factory Preset: CENTER

RISE for W-CDMA

Remarks: You must be in 1xEV-DO or W-CDMA mode to use this command. Use INSTRument:SElect to set the mode.

History: PSA:
Added in version A.02.00

E4406A:
Added in version A.05.00

Power vs. Time—Mask Reference Point Offset

```
[ :SENSe ]:PVTime:MASK:REfERENCE[ :OFFSet ]:TIME <time>
```

```
[ :SENSe ]:PVTime:MASK:REfERENCE[ :OFFSet ]:TIME?
```

Define the time offset of the mask timing reference. This is an advanced control that normally does not need to be changed.

Factory Preset: 0 s

Range: -10 to +10 ms

Remarks: You must be in 1xEV-DO or W-CDMA mode to use this command. Use INSTRument:SElect to set the mode.

History: PSA:
Added in version A.02.00

E4406A:
Added in version A.05.00

Power vs. Time—Custom Limit Masks

```
[ :SENSe ]:PVTime:MASK:SElect STANDARD|CUSTOm
```

```
[ :SENSe ]:PVTime:MASK:SElect?
```

Select standard masks or user-defined custom masks to compare you measured data against.

Factory Preset: STANdard

Remarks: You must be in GSM, EDGE mode to use this command. Use

SENSe Subsystem

INSTRument:SElect to set the mode.

History: E4406A:
Added in revision A.03.00

Power vs Time - Select Power Control Level

Allows user to indicate the output power of the transmitter; in MS testing transmitter output power level will affect the mask. The appropriate power level for measuring the device under test will correspond with the transmitter power control level setting.

[:SENSe] :PVTime:PCLevel <integer>

[:SENSe] :PVTime:PCLevel?

Range: 0 to 40

Remarks: You must be in the power vs. time measurement in GSM, EDGE mode to use this command. Use INSTRument:SElect to set the mode

Front Panel Access: **Meas Setup, More (1 of 2), Pwr Cntrl Lvl.**

History: E4406A:
Added in version A.05.00

Power vs. Time—Slot Type Selection

[:SENSe] :PVTime:SLOT[:TYPE] IDLE|ACTive

[:SENSe] :PVTime:SLOT[:TYPE]?

Set the slot type to either Idle (including Pilot and MAC) or Active (including Pilot, MAC, and Data). Define the reference point of the mask timing.

IDLE - Set to the idle slot that includes the Pilot and MAC channels, of which waveform is bursted.

ACTive - Set to the active slot that includes the Pilot, MAC, and Data channels, of which signal is continuous.

Factory Preset: RISE

Remarks: You must be in 1xEV-DO mode to use this command. Use INSTRument:SElect to set the mode.

History: PSA:
Added in version A.02.00
E4406A:
Added in version A.05.00

Power vs. Time—Sweep Time

```
[ :SENSE]:PVTIME:SWEep:TIME <integer>
```

```
[ :SENSE]:PVTIME:SWEep:TIME?
```

Set the number of slots which are used in each data acquisition. Each slot is approximately equal to 570 ms. The measurement is made for a small additional amount of time (about 130 μ s) in order to view the burst edges.

Factory Preset: 1

Range: 1 to 8 (for resolution BW = 500 kHz)

Remarks: For E4406A you must be in the EDGE(w/GSM), GSM or Service mode to use this command. Use INSTRUMENT:SElect to set the mode.

For PSA you must be in the GSM, EDGE mode to use this command. Use INSTRUMENT:SElect to set the mode.

Power vs. Time—Trigger Source

```
[ :SENSE]:PVTIME:TRIGger:SOURce EXTERNAL[1] | EXTERNAL2  
| FRAME | LINE | IF | IMMEDIATE | RFBURST
```

```
[ :SENSE]:PVTIME:TRIGger:SOURce?
```

Select the trigger source used to control the data acquisitions.

EXTERNAL 1 - front panel external trigger input

EXTERNAL 2 - rear panel external trigger input

FRAME - uses the internal frame timer, which has been synchronized to the selected burst sync.

IF - internal IF envelope (video) trigger

LINE - internal power line frequency trigger

IMMEDIATE - the next data acquisition is immediately taken, capturing the signal asynchronously (also called Free Run).

RFBURST - wideband RF burst envelope trigger that has automatic level control for periodic burst signals.

Factory Preset: RFBURST if the RF Burst Hardware (option B7E) has been installed

EXTERNAL, if option B7E has not been installed

FRAME for 1xEV-DO

Remarks: For E4406A you must be in the EDGE(w/GSM), GSM, Service, 1xEV-DO, or W-CDMA mode to use this command. Use INSTRUMENT:SElect to set the mode.

SENSe Subsystem

Radio Standards Commands

Radio Carrier Hopping

[:SENSe]:RADIo:CARRier:HOP OFF | ON | 0 | 1

[:SENSe]:RADIo:CARRier:HOP?

Turns the carrier hopping mode on and off.

Factory Preset: OFF

Remarks: Global to the current mode.

You must be in the GSM, EDGE mode to use this command.
Use INSTRument:SElect to set the mode.

History: E4406A:
Version A.03.00 or later

Front Panel

Access: **Mode Setup, Radio, Carrier**

Radio Carrier Multiple

[:SENSe]:RADIo:CARRier:NUMBer SINGLE | MULTiple

[:SENSe]:RADIo:CARRier:NUMBer?

Select if single or multiple carriers are present on the output of the base station under test. This enables/disables a software filter for the rho and code domain power measurements.

SINGle – disable software filter.

MULTiple – enable software filter to mitigate the adjacent carrier effects.

Factory Preset: SINGle

Remarks: You must be in the cdmaOne, cdma2000, 1xEV-DO, or iDEN (E4406A) mode to use this command. Use INSTRument:SElect to set the mode.

Front Panel

Access: **Mode Setup, Demod, RF Carrier**

Radio Carrier Burst

[:SENSe]:RADIo:CARRier[:TYPE] BURSt | CONTInuous

[:SENSe]:RADIo:CARRier[:TYPE]?

Select the type of RF carrier on the device to be tested.

Factory Preset: BURSt

SENSe Subsystem

Remarks: You must be in the GSM, EDGE mode to use this command.
Use INSTRument:SELEct to set the mode.

Global to the current mode.

History: E4406A:
Version A.03.00 or later

Front Panel

Access: **Mode Setup, Radio, Carrier**

Radio Device Under Test

```
[ :SENSe ] :RADIo:DEVIce BS |MS
```

```
[ :SENSe ] :RADIo:DEVIce?
```

Select the type of radio device to be tested.

BS – Base station transceiver test

MS – Mobile station transceiver test

Factory Preset: BS

Remarks: You must be in the NADC, or PDC mode to use this command.
Use INSTRument:SELEct to set the mode.

Global to current mode.

Front Panel

Access: **Mode Setup, Radio, Device**

Radio Device Under Test

```
[ :SENSe ] :RADIo:DEVIce BTS |MS
```

```
[ :SENSe ] :RADIo:DEVIce?
```

Select the type of radio device to be tested.

BTS - Base station transmitter test

MS - Mobile station transmitter test

Factory Preset: BTS

Remarks: Global to the current mode.

You must be in cdma2000, GSM, EDGE, W-CDMA or
1xEV-DO mode to use this command. Use INSTRument:SELEct
to set the mode.

History: E4406A:
Version A.03.00 or later

Front Panel

Access: **Mode Setup, Radio, Device**

Radio Device Under Test (E4406A only)

`[:SENSE]:RADIO:DEVICE INBound|OUTBound`

`[:SENSE]:RADIO:DEVICE?`

Select the type of radio device to be tested. If you are testing a base station, it must be put into the test mode to transmit known bit patterns.

OUTBound – Base station transmitter test

INBound – Mobile station transmitter test

Factory Preset: Inbound

Remarks: You must be in the iDEN mode to use this command. Use INSTRUMENT:SELEct to set the mode.

Global to current mode.

Front Panel

Access: **Mode Setup, Radio, Device**

Radio Base Station Type

`[:SENSE]:RADIO:DEVICE:BASE[:TYPE] NORMAl|MICRO|PICO`

`[:SENSE]:RADIO:DEVICE:BASE[:TYPE]?`

Select the type of base station to be tested. If you are testing a base station, it must be put into the test mode to transmit known bit patterns.

Factory Preset: NORMAl

Remarks: You must be in the GSM, EDGE mode to use this command. Use INSTRUMENT:SELEct to set the mode.

Global to current mode.

History: E4406A:
Added revision A.04.00 and later

Front Panel

Access: **Mode Setup, Radio, BTS Type**

Radio Format (Standard) (E4406A only)

`[:SENSE]:RADIO:FORMat M16QAM|M64QAM|DJSMR`

`[:SENSE]:RADIO:FORMat?`

SENSe Subsystem

Select the format that testing will be compliant with when measurements are made.

M16QAM - is a standard iDEN format defined by Motorola

M64QAM - is a standard iDEN format defined by Motorola

DJSMR - is Japanese standard format that is based on the ARIB RCR-32A standard

Factory Preset: M16QAM

Remarks: You must be in the iDEN mode to use this command. Use INSTRUMENT:SElect to set the mode.

History: Version A.03.00 or later

Front Panel

Access: **Mode Setup, Radio, Format**

Radio Standard Band

```
[ :SENSe ] :RADio :STANdard :BAND  
PGSM | EGSM | RGSM | DCS1800 | PCS1900 | GSM450 | GSM480 | GSM700 | GSM850
```

```
[ :SENSe ] :RADio :STANdard :BAND?
```

Select the standard variant that applies to the radio to be tested.

PGSM - Primary GSM in the 900 MHz band

EGSM - Extended GSM in the 900 MHz band

RGSM - Railway GSM in the 900 MHz band

DCS1800 - DCS1800 band; also known as GSM-1800

PCS1900 - PCS1900 band; also known as GSM-1900

GSM450 - GSM450 band

GSM480 - GSM480 band

GSM700 - GSM700band

GSM850 - GSM850 band, for IS-136HS

Factory Preset: EGSM-900

Remarks: Global to the current mode.

You must be in GSM, EDGE mode to use this command. Use INSTRUMENT:SElect to set the mode.

History: E4406A:
More standards added A.02.00, A.03.00

Front Panel

Access: **Mode Setup, Radio, Band**

Radio Standard Band

```
[ :SENSE]:RADIO:STANDARD:BAND IS95A|JSTD8|IS97D
```

```
[ :SENSE]:RADIO:STANDARD:BAND?
```

Select the standard variant that applies to the radio to be tested.

IS95A - IS-95A Cellular

IS97D - IS-97D Cellular

JSTD8 - J-STD-008 PCS

Factory Preset: IS-95A Cellular

Remarks: Global to the current mode.

You must be in the cdmaOne mode to use this command. Use INSTRUMENT:SELECT to set the mode.

Front Panel

Access: **Mode Setup, Radio, Band**

Radio Standard Band

```
[ :SENSE]:RADIO:STANDARD:BAND:CLASS BC0|BC1|BC3|BC4
```

```
[ :SENSE]:RADIO:STANDARD:BAND:CLASS?
```

Select the band class (for IS-97D/98D) that applies to the radio to be tested.

BC0 - Band Class 0 (800 MHz Band [North American & Korean Cellular band])

BC1 - Band Class 1 (1900 MHz Band [North American PCS band])

BC3 - Band Class 3 (JTACS Band [Japan TACS band])

BC4 - Band Class 4 (Korean PCS band)

Factory Preset: BC0

Remarks: Global to the current mode.

You must be in the cdmaOne mode to use this command. Use INSTRUMENT:SELECT to set the mode.

Front Panel

Access: **Mode Setup, Radio, Standard/Band**

Mode Setup, Radio, Band

SENSe Subsystem

Radio Traffic Rate

[:SENSe] :RADIo:TRATe FULL | HALF

[:SENSe] :RADIo:TRATe?

Select the traffic rate.

FULL – full traffic rate (a slot is every 20 ms)

HALF – half traffic rate (a slot is every 40 ms)

Factory Preset: FULL

Remarks: You must be in the NADC or PDC mode to use this command.
Use INSTRument:SELEct to set the mode.

Modulation Accuracy (Rho) Measurement

Commands for querying the rho measurement results and for setting to the default values are found in the “[MEASure Group of Commands](#)” on page 193. The equivalent front panel keys for the parameters described in the following commands, are found under the **Meas Setup** key, after the **Mod Accuracy (Rho)** or **Mod Accuracy (Composite Rho)** measurement has been selected from the **MEASURE** key menu.

Modulation Accuracy – Active Data Channel

[:SENSe] :RHO:ACODE AUTO | PREDeFined

[:SENSe] :RHO:ACODE?

Select the Active Channel ID detection mode Auto or Predefined.

AUTO - detects Active Channel ID for Data Channel automatically.

PREDeFined - set predefined Active Channel (all channel codes) for Data Channel.

Factory Preset: AUTO

Remarks: You must be in the 1xEV-DO mode to use this command. Use INSTRument:SELEct to set the mode.

Modulation Accuracy (Rho) Measurement — ADC Range

[:SENSe] :RHO:ADC:RANGe
AUTO | APEak | APLock | NONE | M6 | P0 | P6 | P12 | P18 | P24

[:SENSe] :RHO:ADC:RANGe?

Select a ranging function for the ADC gain control. This is an advanced control that normally does not need to be changed. If you are measuring a CW signal, see the following description:

- AUTO - automatic ranging

For FFT spectrums, the auto ranging should not be used. An exception to this would be if you know that your signal is “bursty”. Then you might use auto to maximize the time domain dynamic range as long as you are not very interested in the FFT data.

- APEak (Auto Peak) - automatic ranging to the peak signal level

For CW signals, the default of auto-peak ranging can be used, but a better FFT measurement of the signal can be made by selecting one of the manual ranges that is available by specifying M6, or P0 through P24.

Auto peaking can cause the ADC gain to monotonically track the ranges down during the data capture. This tracking effect should be negligible for the FFT spectrum, but selecting a manual range solves this possibility. Note that if the CW signal being measured is close to the auto-ranging threshold, the noise floor may shift as much as 6 dB every sweep.

- APLock (Auto Peak Lock) - automatic ranging locked to the peak signal level

For CW signals, auto-peak lock ranging may be used. It will find the ADC gain most appropriate for this particular signal and will not track the ranges as auto-peak can. Note that if the CW signal being measured is close to the auto-ranging threshold, the noise floor may shift as much as 6 dB every sweep.

For “bursty” signals, auto-peak lock ranging should not be used. Since the ADC range can often be locked to the wrong one resulting in overloading the ADC, the measurement will fail.

- NONE - turns off any auto-ranging without making any changes to the current setting.
- M6 - manually selects an ADC range that subtracts 6 dB from the fixed gain across the range. Manual ranging is best for CW signals.
- P0 thru P24 - manually selects one of the ADC ranges that add 0 dB to 24 dB to the fixed gain across the range. Manual ranging is best for CW signals.

Factory Preset: M6

Remarks: You must be in the 1xEV-DO mode to use this command. Use INSTRUMENT:SELEct to set the mode.

Modulation Accuracy (Rho)—Demod Alpha

[:SENSe]:RHO:ALPHa <numeric>

[:SENSe]:RHO:ALPHa?

Set alpha for the root Nyquist filter.

Factory Preset: 0.22

Range: 0.01 to 0.5

SENSe Subsystem

Remarks: You must be in the W-CDMA mode to use this command. Use INSTRument:SElect to set the mode.

Modulation Accuracy (Rho)—Average Count

[:SENSe] :RHO:AVERAge:COUNT <integer>

[:SENSe] :RHO:AVERAge:COUNT?

Set the number of data acquisitions that will be averaged. After the specified number of averaging counts, the averaging mode (termination control) setting determines the averaging action.

Factory Preset: 10

Range: 1 to 10,000

Remarks: You must be in the cdmaOne, cdma2000, W-CDMA, or 1xEV-DO mode to use this command. Use INSTRument:SElect to set the mode.

Modulation Accuracy (Rho)—Averaging State

[:SENSe] :RHO:AVERAge[:STATE] OFF | ON | 0 | 1

[:SENSe] :RHO:AVERAge[:STATE]?

Turn the modulation accuracy averaging function on or off.

Factory Preset: OFF

ON for cdma2000, W-CDMA, 1xEV-DO

Remarks: You must be in the cdmaOne, cdma2000, W-CDMA, or 1xEV-DO mode to use this command. Use INSTRument:SElect to set the mode.

Modulation Accuracy (Rho)—Averaging Termination Control

[:SENSe] :RHO:AVERAge:TCONtrol EXPonential | REPEAT

[:SENSe] :RHO:AVERAge:TCONtrol?

Select the type of termination control used for the averaging function. This determines the averaging action after the specified number of frames (average count) is reached.

EXPonential - Each successive data acquisition after the average count is reached, is exponentially weighted and combined with the existing average.

REPEAT - After reaching the average count, the averaging is reset and a new average is started.

Factory Preset: REPeat for cdmaOne, cdma2000, W-CDMA, 1xEV-DO

Remarks: You must be in the cdmaOne, cdma2000, W-CDMA, or 1xEV-DO mode to use this command. Use INSTRument:SELEct to set the mode.

Modulation Accuracy (Rho)—CPICH Power Measurement

[:SENSe]:RHO:CPICH[:STATe] OFF | ON | 0 | 1

[:SENSe]:RHO:CPICH[:STATe]?

Set whether CPICH Power measurement is performed or not.

ON: CPICH power measurement is performed.

OFF: CPICH power measurement is NOT performed.

Factory Preset: OFF

Remarks: You must be in the W-CDMA mode to use this command. Use INSTRument:SELEct to set the mode.

Modulation Accuracy (Rho)—Chip Rate

[:SENSe]:RHO:CRATe <freq>

[:SENSe]:RHO:CRATe?

Enter a frequency value to set the chip rate.

Factory Preset: 1.2288 MHz for cdma2000, 1xEV-DO

3.84 MHz for W-CDMA

Range: 1.10592 to 1.35168 MHz for cdma2000, 1xEV-DO

3.456 to 4.224 MHz for W-CDMA

Default Unit: Hz

Remarks: You must be in the cdma2000, W-CDMA, or 1xEV-DO mode to use this command. Use INSTRument:SELEct to set the mode.

Modulation Accuracy (Rho)—Multi Carrier Estimator

[:SENSe]:RHO:MCEStimator OFF | ON | 0 | 1

[:SENSe]:RHO:MCEStimator?

Turns the multi carrier estimator on or off.

OFF - computes the phase information only from one coded signal assuming

SENSe Subsystem

that each code phase is perfectly aligned.

ON - aligns the code phases to be orthogonal before computing the phase information.

Factory Preset: OFF

Remarks: You must be in the cdma2000, W-CDMA, or 1xEV-DO mode to use this command. Use INSTRument:SElect to set the mode.

Modulation Accuracy (Rho)—PN Offset

[:SENSe] :RHO:PNOffset <integer>

[:SENSe] :RHO:PNOffset?

Set a PN sequence number for the base station being tested. This value behaves as a multiplier for the Walsh codes of which length is in the unit of 64 chips.

Factory Preset: 0

Range: 0 to 511

Unit: 64 chips

Remarks: You must be in the 1xEV-DO mode to use this command. Use INSTRument:SElect to set the mode.

Modulation Accuracy (Rho)—PRACH Preamble Signature

[:SENSe] :RHO:PRACH:SIGNature <integer>

[:SENSe] :RHO:PRACH:SIGNature?

Set Signature number for PRACH Preamble detection, when [:SENSe]:RHO:PRACH:SIGNature:AUTO is set to OFF. This value is set at its auto number if PRACH Preamble Signature Auto mode is set to ON.

Factory Preset: 0

Range: 0 to 15

Remarks: You must be in the W-CDMA mode to use this command. Use INSTRument:SElect to set the mode.

Modulation Accuracy (Rho)—PRACH Preamble Signature Detection

[:SENSe] :RHO:PRACH:SIGNature:AUTO OFF | ON | 0 | 1

[:SENSe] :RHO:PRACH:SIGNature:AUTO?

Set Signature Auto mode ON for PRACH Preamble detection.

Factory Preset: ON

Remarks: You must be in the W-CDMA mode to use this command. Use INSTRUMENT:SELEct to set the mode.

Modulation Accuracy (Rho)—Preamble Length

[:SENSe] :RHO:PREAmble:LENGth <integer>

[:SENSe] :RHO:PREAmble:LENGth?

Set the Preamble length manually in chips.

Factory Preset: 0

Range: 0, 64, 128, 256, 512 and 1024

Remarks: You must be in the 1xEV-DO mode to use this command. Use INSTRUMENT:SELEct to set the mode.

Modulation Accuracy (Rho)—Preamble Auto Detection

[:SENSe] :RHO:PREAmble:LENGth:AUTO OFF | ON | 0 | 1

[:SENSe] :RHO:PREAmble:LENGth:AUTO?

Turn the Preamble Length detection mode on or off.

On - detects the Preamble length automatically.

Off - sets the Preamble length manually by
[:SENSe]:RHO:PREAmble:LENGth.

Factory Preset: ON

Remarks: You must be in the 1xEV-DO mode to use this command. Use INSTRUMENT:SELEct to set the mode.

Modulation Accuracy (Rho)—Rho Overall Preamble Included

[:SENSe] :RHO:PREAmble:STATE OFF | ON | 0 | 1

[:SENSe] :RHO:PREAmble:STATE?

Select whether or not Preamble is included for Rho Overall calculation.

On – Preamble chips is included for Rho Overall calculation

Off – Preamble chips is Not included for Rho Overall calculation.

Factory Preset: ON

Remarks: You must be in the 1xEV-DO mode to use this command. Use INSTRUMENT:SELEct to set the mode.

SENSe Subsystem

Modulation Accuracy (Rho)—Symbol Boundary for BTS

Select the symbol boundary detection mode. This command is effective when the [:SENSe] :RADIo :DEVice is set to BTS.

```
[ :SENSe ] :RHO :SBOundary [ :BTS ]  
AUTO | MAX | TM1D16 | TM1D32 | TM1D64 | TM2 | TM3D16 | TM3D32 | TM4 | TM4CP |  
TM1D16SC | TM1D32SC | TM1D64SC | TM2SC | TM3D16SC | TM3D32SC
```

[:SENSe] :RHO :SBOundary?

Auto - sets the symbol boundary detection to the automatic mode. Various code channel are measured and the most appropriate code channel is determined as the reference channel.

TM1D16 - sets the code domain power measurement to Test Model 1 with 16 DPCH channels.

TM1D32 - sets the code domain power measurement to Test Model 1 with 32 DPCH channels.

TM1D64 - sets the code domain power measurement to Test Model 1 with 64 DPCH channels.

TM2 - sets the code domain power measurement to Test Model 2.

TM3D16 - sets the code domain power measurement to Test Model 3 with 16 DPCH channels.

TM3D32 - sets the code domain power measurement to Test Model 3 with 32 DPCH channels.

TM4 - sets the symbol boundary detection to Test Model 4 w/o Primary CCPCH channel.

TM4CP - sets the symbol boundary detection to Test Model 4 with Primary CCPCH channel.

TM1D16SC -sets the symbol boundary detection to Test Model 1 with 16 DPCH channels including S-CCPCH [PCH].

TM1D32SC -sets the symbol boundary detection to Test Model 1 with 32 DPCH channels including S-CCPCH [PCH].

TM1D64SC -sets the symbol boundary detection to Test Model 1 with 64 DPCH channels including S-CCPCH [PCH].

TM2SC -sets the symbol boundary detection to Test Model 2 with S-CCPCH [PCH] channel.

TM3D16SC -sets the symbol boundary detection to Test Model 3 with 16 DPCH channels including S-CCPCH [PCH].

TM3D32SC -sets the symbol boundary detection to Test Model 3 with 32 DPCH channels including S-CCPCH [PCH].

Factory Preset: Auto

Remarks You must be in the W-CDMA (3GPP) mode to use this command. Use INSTRUMENT:SElect to set the mode.

Modulation Accuracy (Rho)—Slot Format for MS

[:SENSE]:RHO:SFORmat:MS SF0 | SF1 | SF2 | SF3 | SF4 | SF5

[:SENSE]:RHO:SFORmat:MS?

Set the slot format to define DPCCH pilot pattern to synchronize with, when the [:SENSE]:RADIO:DEVICE is set to MS.

SF0 - slot format 0.

SF1 - slot format 1.

SF2 - slot format 2.

SF3 - slot format 3.

SF4 - slot format 4.

SF5 - slot format 5.

Factory Preset: SF0

Remarks: You must be in the W-CDMA mode to use this command. Use INSTRUMENT:SElect to set the mode.

Modulation Accuracy (Rho)—Spectrum Normal/Invert

[:SENSE]:RHO:SPECTrum INVert | NORMal

[:SENSE]:RHO:SPECTrum?

Set a spectrum either to normal or inverted for the demodulation related measurements. If set to INVert, the upper and lower spectrums are swapped.

Factory Preset: NORMal

Remarks You must be in the cdmaOne, cdma2000, W-CDMA, or 1xEV-DO mode to use this command. Use INSTRUMENT:SElect to set the mode.

Modulation Accuracy (Rho)—Sweep Time (Measurement Interval)

[:SENSE]:RHO:SWEep:TIME <time>

[:SENSE]:RHO:SWEep:TIME?

Set the length of the measurement interval that will be used.

Factory Preset: 1.250 ms

SENSe Subsystem

Range: 0.5 ms to 30 ms

Default Unit: seconds

Remarks: You must be in the cdmaOne mode to use this command. Use INSTRUMENT:SElect to set the mode.

Modulation Accuracy (Rho)— Include SCH in Measurement Interval

[:SENSe] :RHO :SWEEp :TIME :SCH INCLude | EXCLude

[:SENSe] :RHO :SWEEp :TIME :SCH?

Selects whether the measurement computation includes the first 10% part of a slot where the SCH (synch channel) exists.

INCLude -> The computation is performed in a whole slot including the SCH.

EXCLude -> The computation is performed in the last 90% of a slot, which means that it excludes the SCH..

Factory Preset: Exclude

Remarks: You must be in the W-CDMA mode to use this command. Use INSTRUMENT:SElect to set the mode.

Modulation Accuracy (Rho)—Sync Type (BTS)

[:SENSe] :RHO :SYNC [:BTS] CPICH | SCH | SYMBol | STTD | A2CPich

[:SENSe] :RHO :SYNC [:BTS]?

Set the synchronization type for BTS. (When the [:SENSe] :RADIo :DEVice is set to MS, dedicated physical control channel (DPCCH) is automatically set to the sync channel.)

CPICH - synchronize to common pilot channel (CPICH).

SCH - synchronize to synchronization channel (SCH).

Symbol - synchronize to the code symbol specified by the

[:SENSe] :RHO :SYNC :SYMBol :SRATe and the

[:SENSe] :RHO :SYNC :SYMBol :SPReAd commands.

A2CPich: (Antenna-2 CPICH) synchronize to Antenna-2 common pilot channel (CPICH)

STTD: synchronize to common pilot channel at Antenna-1 and Antenna-2. (This is used for Diversity Time Error measurement.)

Factory Preset: CPICH

Remarks: You must be in the W-CDMA mode to use this command. Use INSTRUMENT:SElect to set the mode.

Modulation Accuracy (Rho)—Sync Type (MS)

```
[ :SENSe ] :RHO:SYNC:MS DPCCh | PMESage
```

```
[ :SENSe ] :RHO:SYNC:MS?
```

Select DPCCh or PMESage for synchronization to uplink signal.

DPCCh - Synchronize to DPCCH and Slot Format which is specified by
[:SENSe]:RHO:SFORmat:MS

PMESage - Synchronize to PRACH Message and Slot Format which is
specified by [:SENSe]:RHO:SFORmat:MS

Factory Preset: DPCCh

Remarks: You must be in the W-CDMA mode to use this command. Use
INSTrument:SELEct to set the mode.

Modulation Accuracy (Rho)—Long Code Mask

```
[ :SENSe ] :RHO:SYNC:LCMask <integer>
```

```
[ :SENSe ] :RHO:SYNC:LCMask?
```

Set the long code mask for MS measurement.

Factory Preset: 2,199,023,255,552 (20,000,000,000h)

Range: 0 to 4,398,046,511,103 (0h to 3F,FFF,FFF,FFFh)

Remarks: You must be in the cdma2000 mode to use this command. Use
INSTrument:SELEct to set the mode.

Modulation Accuracy (Rho)—Scramble Code Down Link

```
[ :SENSe ] :RHO:SYNC:SCRamble[ :BTS ] <integer>
```

```
[ :SENSe ] :RHO:SYNC:SCRamble[ :BTS ]?
```

Set the BTS primary scramble code for synchronization.

Factory Preset: 0

Range: 0 to 511

Remarks: You must be in the W-CDMA mode to use this command. Use
INSTrument:SELEct to set the mode.

Modulation Accuracy (Rho)—Scramble Code Offset

```
[ :SENSe ] :RHO:SYNC:SCRamble[ :BTS ] :OFFSet <integer>
```

SENSe Subsystem

[:SENSe] :RHO:SYNC:SCRamble[:BTS] :OFFSet?

Set the BTS scramble code offset (secondary scramble code) for synchronization.

Factory Preset: 0

Range: 0 to 15

Remarks: You must be in the W-CDMA mode to use this command. Use INSTRument:SElect to set the mode.

Modulation Accuracy (Rho)—Sync Scramble Code Type Down Link

[:SENSe] :RHO:SYNC:SCRamble[:BTS] :TYPE LEFT | RIGHT | STANdard

[:SENSe] :RHO:SYNC:SCRamble[:BTS] :TYPE?

Set the BTS primary scramble code type for synchronization.

LEFT – the left alternative scrambling code whose number is the primary scramble code number + 8192 is used.

RIGHT – the right alternative scrambling code whose number is the primary scrambling code number + 16384 is used.

STANdard – the standard scrambling code whose number is the primary scrambling code number is used.

Factory Preset: STANdard

Remarks: You must be in the W-CDMA mode to use this command. Use INSTRument:SElect to set the mode.

Modulation Accuracy (Rho)—Scramble Code Up Link

[:SENSe] :RHO:SYNC:SCRamble:MS <integer>

[:SENSe] :RHO:SYNC:SCRamble:MS?

Set the MS scramble code for synchronization.

Factory Preset: 0

Range: 0 to 16,777,215 (0h to FFF,FFFh)

Remarks: You must be in the W-CDMA mode to use this command. Use INSTRument:SElect to set the mode.

Modulation Accuracy (Rho)—Synchronization Symbol Spread Code

[:SENSe] :RHO:SYNC:SYMBOL:SPRead <integer>

[:SENSe] :RHO:SYNC:SYMBOL:SPRead?

Set the spread code of the code symbol to synchronize with. This command is effective when the [:SENSe] :RHO:SYNC command is set to SYMBOL.

Factory Preset: 1

Range: 0 to 511, when :SENS:RHO:SYNC:SYMB:SRAT = 7500
 0 to 255, when :SENS:RHO:SYNC:SYMB:SRAT = 15000
 0 to 127, when :SENS:RHO:SYNC:SYMB:SRAT = 30000
 0 to 63, when :SENS:RHO:SYNC:SYMB:SRAT = 60000
 0 to 31, when :SENS:RHO:SYNC:SYMB:SRAT = 120000
 0 to 15, when :SENS:RHO:SYNC:SYMB:SRAT = 240000
 0 to 7, when :SENS:RHO:SYNC:SYMB:SRAT = 480000
 0 to 3, when :SENS:RHO:SYNC:SYMB:SRAT = 960000

Remarks: You must be in the W-CDMA mode to use this command. Use INSTRUMENT:SELEct to set the mode.

Modulation Accuracy (Rho)—Synchronization Symbol Spread Rate

[:SENSe] :RHO:SYNC:SYMBol:SRATe <integer>

[:SENSe] :RHO:SYNC:SYMBol:SRATe?

Set the symbol rate of the code symbol to synchronize with. This command is effective when the [:SENSe] :RHO:SYNC command is set to SYMBOL.

Factory Preset: 7500

Range: 7500, 15000, 30000, 60000, 120000, 240000, 480000, 960000

Remarks: You must be in the W-CDMA mode to use this command. Use INSTRUMENT:SELEct to set the mode.

Modulation Accuracy (Rho)—Trigger Source

[:SENSe] :RHO:TRIGger:SOURce

EXTernal[1] | EXTernal2 | FRAMe | IF | IMMEDIATE | RFBurst

[:SENSe] :RHO:TRIGger:SOURce?

Select the trigger source used to control the data acquisitions.

EXTernal 1 – front panel external trigger input

EXTernal 2 – rear panel external trigger input

FRAMe – internal frame trigger

IF – internal IF envelope (video) trigger

SENSE Subsystem

IMMEDIATE – the next data acquisition is immediately taken, capturing the signal asynchronously (also called free run).

RFBURST – internal wideband RF burst envelope trigger that has automatic level control for periodic burst signals.

Factory Preset: IMMEDIATE

Remarks: You must be in the cdmaOne, cdma2000, W-CDMA, or 1xEV-DO mode to use this command. Use INSTRUMENT:SELECT to set the mode.

Front Panel

Access: **Meas Setup, Trig Source**

Reference Oscillator Commands

Reference Oscillator External Frequency

[:SENSe]:ROSCillator:EXTernal:FREQuency <frequency>

[:SENSe]:ROSCillator:EXTernal:FREQuency?

Specify to the frequency of the external reference being supplied to the instrument. Switch to the external reference with ROSC:SOUR.

Preset

and *RST: Value remains at last user selected value (persistent)

Factory default, 10 MHz

Range: 1 MHz to 30 MHz, with 1 Hz steps

Default Unit: Hz

Remarks: Global to system

Front Panel

Access: **System, Reference, Ref Oscillator**

Reference Oscillator Rear Panel Output

[:SENSe]:ROSCillator:OUTPut[:STATe] OFF | ON | 0 | 1

[:SENSe]:ROSCillator:OUTPut?

Turn on and off the 10 MHz frequency reference signal going to the rear panel.

Preset

and *RST: Persistent State with factory default of On

Remarks: Global to system. Was SENS:ROSC:REAR

Front Panel

Access: **System, Reference, 10 MHz Out**

Reference Oscillator Source

[:SENSe]:ROSCillator:SOURce INTernal | EXTernal

[:SENSe]:ROSCillator:SOURce?

Select the reference oscillator (time base) source. Use ROSC:EXT:FREQ to tell the instrument the frequency of the external reference.

INTernal - uses internally generated 10 MHz reference signal

EXTernal - uses the signal at the rear panel external reference input port.

Preset

SENSE Subsystem

and *RST: Persistent State with factory default of Internal
Remarks: Global to system.
Front Panel
Access: **System, Reference, Ref Oscillator**

Spectrum Emission Mask Measurement (Spurious Emissions)

Commands for querying the Spectrum Emission Mask measurement results and for setting to the default values are found in the “[MEASure Group of Commands](#)” on page 193. The equivalent front panel keys for the parameters described in the following commands, are found under the **Meas Setup** key, after selecting the measurement from the **MEASURE** key menu. Select the **Spectrum Emission Mask** measurement (for W-CDMA, cdma2000) or the **Spurious Emissions and ACP** measurement (for 1xEV-DO).

History: E4406A:
Added version A.04.00 and later

Spectrum Emission Mask—Average Count

```
[ :SENSE ] :SEMask:AVERAge:COUNT <integer>
```

```
[ :SENSE ] :SEMask:AVERAge:COUNT?
```

Set the number of data acquisitions that will be averaged. After the specified number of average count, the average mode (termination control) setting determines the average action.

Factory Preset: 10

Range: 1 to 10,000

Remarks: You must be in the cdma2000, W-CDMA, or 1xEV-DO mode to use this command. Use INSTRument:SElect to set the mode.

Spectrum Emission Mask—Averaging State

```
[ :SENSE ] :SEMask:AVERAge[ :STATe ] OFF | ON | 0 | 1
```

```
[ :SENSE ] :SEMask:AVERAge[ :STATe ]?
```

Turn the averaging function On or Off.

Factory Preset: OFF

Remarks: You must be in the cdma2000, W-CDMA, or 1xEV-DO mode to use this command. Use INSTRument:SElect to set the mode.

Spectrum Emission Mask—Averaging Termination Control

```
[ :SENSe ] :SEMAsk :AVERAge :TCONTrOl EXPOnential |REPEat
```

```
[ :SENSe ] :SEMAsk :AVERAge :TCONTrOl?
```

Select the type of termination control used for averaging. This determines the averaging action after the specified number of data acquisitions (average count) is reached.

EXPOnential - Each successive data acquisitions after the average count is reached is exponentially weighted and combined with the existing average.

REPEat - After reaching the average count, the averaging is reset and a new average is started.

Factory Preset: EXPOnential

Remarks: You must be in the 1xEV-DO mode to use this command. Use INSTRument:SELEct to set the mode.

Spectrum Emission Mask—Reference Channel Integration Bandwidth

cdma2000, W-CDMA mode

```
[ :SENSe ] :SEMAsk :BANDwidth[n] |BWIDth[n] :INTEgration <freq>
```

```
[ :SENSe ] :SEMAsk :BANDwidth[n] |BWIDth[n] :INTEgration?
```

1xEV-DO mode

```
[ :SENSe ] :SEMAsk :BANDwidth |BWIDth :INTEgration[m] <freq>
```

```
[ :SENSe ] :SEMAsk :BANDwidth |BWIDth :INTEgration[m]?
```

Set the integration bandwidth that will be used for the reference channel.

BANDwidth[n]|BWIDth[n]

n=1 is the base station test and n=2 is the mobile station test.

The default is the base station test (1). (cdma2000, W-CDMA mode only)

INTEgration[m] m=1 is the spectrum emission mask (SEM) mode and m=2 is the adjacent channel power (ACP) mode. The default is the SEM mode (1). (1xEV-DO mode only)

Factory Preset: 1.23 MHz for cdma2000, 1xEV-DO

3.84 MHz for W-CDMA

Range: 100.0 kHz to 1.250 MHz

Default Unit: Hz

Remarks: You must be in the cdma2000, W-CDMA, or 1xEV-DO mode to use this command. Use INSTRument:SELEct to set the mode.

SENSe Subsystem

Spectrum Emission Mask—Reference Channel Resolution Bandwidth

cdma2000, W-CDMA mode

```
[ :SENSe ] :SEMAsk :BANDwidth[n] | BWIDth[n] :RESolution <freq>
```

```
[ :SENSe ] :SEMAsk :BANDwidth[n] | BWIDth[n] :RESolution?
```

1xEV-DO mode

```
[ :SENSe ] :SEMAsk :BANDwidth | BWIDth :RESolution[m] <freq>
```

```
[ :SENSe ] :SEMAsk :BANDwidth | BWIDth :RESolution[m]?
```

Set the resolution bandwidth for the reference channel.

BANDwidth[n]|BWIDth[n]

n=1 is the base station test and n=2 is the mobile station test.
The default is the base station test (1). (cdma2000, W-CDMA mode only)

RESolution[m] m=1 is the spectrum emission mask (SEM) mode and m=2 is the adjacent channel power (ACP) mode. The default is the SEM mode (1). (1xEV-DO mode only)

Factory Preset: No valid value as the default is set to Auto. See [:SENS]:SEM:BANDwidth[n]|BWIDth[n]:RES[m]:AUTO.

Range: 1.0 kHz to 7.5 MHz

Default Unit: Hz

Remarks: You must be in the cdma2000, W-CDMA, or 1xEV-DO mode to use this command. Use INSTRument:SELEct to set the mode.

Spectrum Emission Mask—Auto Mode for Reference Channel Resolution Bandwidth

cdma2000, W-CDMA mode

```
[ :SENSe ] :SEMAsk :BANDwidth[n] | BWIDth[n] :RESolution :AUTO  
OFF | ON | 0 | 1
```

```
[ :SENSe ] :SEMAsk :BANDwidth[n] | BWIDth[n] :RESolution :AUTO?
```

1xEV-DO mode

```
[ :SENSe ] :SEMAsk :BANDwidth | BWIDth :RESolution[m] :AUTO  
OFF | ON | 0 | 1
```

```
[ :SENSe ] :SEMAsk :BANDwidth | BWIDth :RESolution[m] :AUTO?
```

Set the auto mode to determine the resolution bandwidth to On or Off. If set to Off, enter a frequency value referring to [:SENS]:SEM:BANDwidth[n]|BWIDth[n]:RES[m].

BANDwidth[n]|BWIDth[n]

n=1 is the base station test and n=2 is the mobile station test.

The default is the base station test (1). (cdma2000, W-CDMA mode only)

RESolution[m] m=1 is the spectrum emission mask (SEM) mode and m=2 is the adjacent channel power (ACP) mode. The default is the SEM mode (1). (1xEV-DO mode only)

Factory Preset: ON

Remarks: You must be in the cdma2000, W-CDMA, or 1xEV-DO mode to use this command. Use INSTRument:SElect to set the mode.

Spectrum Emission Mask—Detector Mode

[:SENSe] :SEMAsk :DETEctor [:FUNction] AAverage | POSitive

[:SENSe] :SEMAsk :DETEctor [:FUNction] ?

Select one of the detector modes for spectrum measurements.

AAverage (absolute average) - the absolute average power in each frequency is measured across the spectrum

POSitive - the positive peak power in each frequency is measured across the spectrum

Factory Preset: AAverage (absolute average)

Remarks: You must be in the cdma2000, W-CDMA, or 1xEV-DO mode to use this command. Use INSTRument:SElect to set the mode.

Spectrum Emission Mask—Channel Frequency Span

[:SENSe] :SEMAsk :FREQUency [n] :SPAN [m] <freq>

[:SENSe] :SEMAsk :FREQUency [n] :SPAN [m] ?

Enter a frequency value to set the channel frequency span for the reference channel integration.

FREQUency[n] n=1 is the base station test and n=2 is the mobile test. The default is the base station test (1). (cdma2000, W-CDMA mode only)

SPAN[m] m=1 is the spectrum emission mask (SEM) mode and m=2 is the adjacent channel power (ACP) mode. The default is the SEM mode (1). (1xEV-DO mode only)

Factory Preset: 1.25 MHz for cdma2000, 1xEV-DO
5.0 MHz for W-CDMA

Range: 100.0 kHz to 10.0 MHz

Remarks: You must be in the cdma2000, W-CDMA, or 1xEV-DO mode to

SENSe Subsystem

use this command. Use INSTRument:SElect to set the mode.

Spectrum Emission Mask—Reference Channel Step Frequency

cdma2000, W-CDMA mode

```
[ :SENSe ] :SEMAsk:FREQuency[n]:STEP <freq>
```

```
[ :SENSe ] :SEMAsk:FREQuency[n]:STEP?
```

1xEV-DO mode

```
[ :SENSe ] :SEMAsk:FREQuency:STEP[m] <freq>
```

```
[ :SENSe ] :SEMAsk:FREQuency:STEP[m]?
```

Enter a frequency value to set the step frequency for the reference channel integration.

FREQuency[n] n=1 is the base station test and n=2 is the mobile test. The default is the base station test (1). (cdma2000, W-CDMA mode only)

STEP[m] m=1 is the spectrum emission mask (SEM) mode and m=2 is the adjacent channel power (ACP) mode. The default is the SEM mode (1). (1xEV-DO mode only)

Factory Preset: No valid value as the default is set to Auto. See [:SENS]:SEM:FREQ[n]:STEP[m]:AUTO.

Range: 100 Hz to 7.5 MHz

Remarks: You must be in the cdma2000, W-CDMA, or 1xEV-DO mode to use this command. Use INSTRument:SElect to set the mode.

Spectrum Emission Mask—Auto Mode for Reference Channel Step Frequency

cdma2000, W-CDMA mode

```
[ :SENSe ] :SEMAsk:FREQuency[n]:STEP:AUTO OFF|ON|0|1
```

```
[ :SENSe ] :SEMAsk:FREQuency[n]:STEP:AUTO?
```

1xEV-DO mode

```
[ :SENSe ] :SEMAsk:FREQuency:STEP[m]:AUTO OFF|ON|0|1
```

```
[ :SENSe ] :SEMAsk:FREQuency:STEP[m]:AUTO?
```

Set the auto mode to determine the step frequency to On or Off.

OFF - enter a value to set the step frequency for the reference channel integration, referring to [:SENS]:SEM:FREQ[n]:STEP[m].

ON - the step frequency for the reference channel integration is set to a half of

the resolution bandwidth.

- FREQuency[n] n=1 is the base station test and n=2 is the mobile test. The default is the base station test (1). (cdma2000, W-CDMA mode only)
- STEP[m] m=1 is the spectrum emission mask (SEM) mode and m=2 is the adjacent channel power (ACP) mode. The default is the SEM mode (1). (1xEV-DO mode only)
- Factory Preset: ON
- Remarks: You must be in the cdma2000, W-CDMA, or 1xEV-DO mode to use this command. Use INSTRument:SElect to set the mode.

Spectrum Emission Mask—Offset Resolution Bandwidth

cdma2000, W-CDMA mode

```
[ :SENSe ] :SEMAsk:OFFSet[n] :LIST:BA NDwidth | BWIDTh
<res_bw> , <res_bw> , <res_bw> , <res_bw> , <res_bw>
```

```
[ :SENSe ] :SEMAsk:OFFSet[n] :LIST:BA NDwidth | BWIDTh?
```

1xEV-DO mode

```
[ :SENSe ] :SEMAsk:OFFSet:LIST[m] :BA NDwidth | BWIDTh
<res_bw> , <res_bw> , <res_bw> , <res_bw> , <res_bw>
```

```
[ :SENSe ] :SEMAsk:OFFSet:LIST[m] :BA NDwidth | BWIDTh?
```

Define the offset resolution bandwidth for Spectrum Emission Mask measurements. The list must contain five (5) entries. You can turn off (not use) specific offsets with [:SENS]:SEM:OFFS[n]:LIST[m]:STAT.

- OFFSet[n] n=1 is the base station test and n=2 is the mobile test. The default is the base station test (1). (cdma2000, W-CDMA only)
- LIST[m] m=1 is the spectrum emission mask (SEM) mode and m=2 is the adjacent channel power (ACP) mode. The default is the SEM mode (1). (1xEV-DO mode only)

Factory Preset:

Mode	Variant	Offset A	Offset B	Offset C	Offset D	Offset E
cdma2000	BTS	3.00 kHz	30.00 kHz	30.0 kHz	6.25 kHz	1.000 MHz
	MS	30.00 kHz	30.00 kHz	6.25 kHz	1.000 MHz	1.000 MHz
W-CDMA	BTS	30.00 kHz	30.00 kHz	30.00 kHz	50.00 kHz	1.000 MHz
	MS	30.00 kHz	1.000 MHz	1.000 MHz	1.000 MHz	1.000 MHz

SENSe Subsystem

Mode	Variant	Offset A	Offset B	Offset C	Offset D	Offset E
1xEV-DO	SEM	3.000 kHz	30.00 kHz	30.00 kHz	6.250 kHz	1.000 MHz
	ACP	3.000 kHz	30.00 kHz	30.00 kHz	30.00 kHz	30.00 kHz

Range: 300 Hz to 7.5 MHz

Default Unit: Hz

Remarks: You must be in the cdma2000, W-CDMA, or 1xEV-DO mode to use this command. Use INSTRument:SElect to set the mode.

Spectrum Emission Mask—Auto Offset Resolution Bandwidth

cdma2000, W-CDMA mode

```
[ :SENSe ] :SEMAsk:OFFSet[n]:LIST:BANDwidth|BWIDth:AUTO
OFF|ON|0|1,OFF|ON|0|1,OFF|ON|0|1,OFF|ON|0|1,OFF|ON|0|1
```

```
[ :SENSe ] :SEMAsk:OFFSet[n]:LIST:BANDwidth|BWIDth:AUTO?
```

1xEV-DO mode

```
[ :SENSe ] :SEMAsk:OFFSet:LIST[m]:BANDwidth|BWIDth:AUTO
OFF|ON|0|1,OFF|ON|0|1,OFF|ON|0|1,OFF|ON|0|1,OFF|ON|0|1
```

```
[ :SENSe ] :SEMAsk:OFFSet:LIST[m]:BANDwidth|BWIDth:AUTO?
```

Set the auto mode to determine the offset resolution bandwidth to On or Off.

OFF - enter a value to set the resolution bandwidth for an offset channel, referring to [:SENS]:SEM:OFFS[n]:LIST[m]BAND|BWID.

ON - the resolution bandwidth for an offset channel is automatically set according to the offset start and stop frequencies.

OFFSet[n] n=1 is the base station test and n=2 is the mobile test. The default is the base station test (1). (cdma2000, W-CDMA mode only)

LIST[m] m=1 is the spectrum emission mask (SEM) mode and m=2 is the adjacent channel power (ACP) mode. The default is the SEM mode (1). (1xEV-DO mode only)

Factory Preset and *RST:

Mode	Variant	Offset A	Offset B	Offset C	Offset D	Offset E
cdma2000		OFF	OFF	OFF	OFF	OFF
W-CDMA		OFF	OFF	OFF	OFF	OFF

Mode	Variant	Offset A	Offset B	Offset C	Offset D	Offset E
1xEV-DO	SEM	OFF	OFF	OFF	OFF	OFF
	ACP	OFF	OFF	OFF	OFF	OFF

Remarks: You must be in the cdma2000, W-CDMA, or 1xEV-DO mode to use this command. Use INSTRument:SElect to set the mode.

Spectrum Emission Mask—Offset Resolution Bandwidth Multiplier

cdma2000, W-CDMA mode

```
[ :SENSE ]:SEMAsk:OFFSet[n]:LIST:BANDwidth|BWIDth:IMULti
<integer>,<integer>,<integer>,<integer>,<integer>
```

```
[ :SENSE ]:SEMAsk:OFFSet[n]:LIST:BANDwidth|BWIDth:IMULti?
```

1xEV-DO mode

```
[ :SENSE ]:SEMAsk:OFFSet:LIST[m]:BANDwidth|BWIDth:IMULti
<integer>,<integer>,<integer>,<integer>,<integer>
```

```
[ :SENSE ]:SEMAsk:OFFSet:LIST[m]:BANDwidth|BWIDth:IMULti?
```

Specify a multiplier of the offset resolution bandwidth for the offset measurement integration bandwidth.

OFFSet[n] n=1 is the base station test and n=2 is the mobile test. The default is the base station test (1). (cdma2000, W-CDMA mode only)

LIST[m] m=1 is the spectrum emission mask (SEM) mode and m=2 is the adjacent channel power (ACP) mode. The default is the SEM mode (1). (1xEV-DO mode only)

Factory Preset:

Mode	Variant	Offset A	Offset B	Offset C	Offset D	Offset E
cdma2000	BTS	10	1	1	1	1
	MS	1	1	1	1	1
W-CDMA	BTS	1	1	1	20	1
	MS	1	1	1	1	1
1xEV-DO	SEM	10	1	1	1	1
	ACP	10	1	1	1	1

Range: 1 to ((Stop frequency – Start frequency) / Resolution bandwidth)

SENSe Subsystem

Remarks: You must be in the cdma2000, W-CDMA, or 1xEV-DO mode to use this command. Use INSTRUMENT:SELEct to set the mode.

Spectrum Emission Mask—Offset Start Frequency

cdma2000, W-CDMA mode

```
[ :SENSe ] :SEMAsk:OFFSet [ n ] :LIST:FREQuency:START
<f_offset> , <f_offset> , <f_offset> , <f_offset> , <f_offset>
```

```
[ :SENSe ] :SEMAsk:OFFSet [ n ] :LIST:FREQuency:START?
```

1xEV-DO mode

```
[ :SENSe ] :SEMAsk:OFFSet:LIST [ m ] :FREQuency:START
<f_offset> , <f_offset> , <f_offset> , <f_offset> , <f_offset>
```

```
[ :SENSe ] :SEMAsk:OFFSet:LIST [ m ] :FREQuency:START?
```

Set the five (5) sets of the offset start frequencies.

OFFSet[n] n=1 is the base station test and n=2 is the mobile test. The default is the base station test (1). (cdma2000, W-CDMA mode only)

LIST[m] m=1 is the spectrum emission mask (SEM) mode and m=2 is the adjacent channel power (ACP) mode. The default is the SEM mode (1). (1xEV-DO mode only)

Factory Preset:

Mode	Variant	Offset A	Offset B	Offset C	Offset D	Offset E
cdma2000	BTS	765.0 kHz	795.0 kHz	1.195 MHz	3.2531 MHz	7.500 MHz
	MS	900.0 kHz	1.995 MHz	2.2531 MHz	8.500 MHz	12.50 MHz
W-CDMA	BTS	2.515 MHz	2.715 MHz	3.515 MHz	4.000 MHz	8.000 MHz
	MS	2.515 MHz	4.000 MHz	7.500 MHz	8.5 00MHz	12.50 MHz
1xEV-DO	SEM	765.0 kHz	795.0 kHz	1.995 MHz	3.2531 MHz	7.500 MHz
	ACP	765.0 kHz	1.995 MHz	3.125 MHz	4.000 MHz	7.500 MHz

Range: 10.0 kHz to 100.0 MHz

Default Unit: Hz

Remarks: You must be in the cdma2000, W-CDMA, or 1xEV-DO mode to use this command. Use INSTRUMENT:SELEct to set the mode.

Spectrum Emission Mask—Offset Step Frequency*cdma2000, W-CDMA mode*

```
[ :SENSe ] :SEMAsk:OFFSet [n] :LIST:FREQuency:STEP
<f_offset>,<f_offset>,<f_offset>,<f_offset>,<f_offset>
```

```
[ :SENSe ] :SEMAsk:OFFSet [n] :LIST:FREQuency:STEP?
```

1xEV-DO mode

```
[ :SENSe ] :SEMAsk:OFFSet:LIST[m] :FREQuency:STEP
<f_offset>,<f_offset>,<f_offset>,<f_offset>,<f_offset>
```

```
[ :SENSe ] :SEMAsk:OFFSet:LIST[m] :FREQuency:STEP?
```

Set the five (5) sets of the offset step frequencies.

OFFSet[n] n=1 is the base station test and n=2 is the mobile test. The default is the base station test (1). (cdma2000, W-CDMA mode only)

LIST[m] m=1 is the spectrum emission mask (SEM) mode and m=2 is the adjacent channel power (ACP) mode. The default is the SEM mode (1). (1xEV-DO mode only)

Factory Preset: No valid value as the default is set to Auto. See [:SENS]:SEM:OFF[n]:LIST[m]:FREQuency:STEP:AUTO.

Range: 100 Hz to 7.5 MHz
 The minimum value is determined to be equal to or greater than one 2000th (1/2000) of the frequency difference derived from (Stop Freq – Start Freq).

Default Unit: Hz

Remarks: You must be in the cdma2000, W-CDMA, or 1xEV-DO mode to use this command. Use INSTRument:SElect to set the mode.

Spectrum Emission Mask—Auto Offset Step Frequency*cdma2000, W-CDMA mode*

```
[ :SENSe ] :SEMAsk:OFFSet [n] :LIST:FREQuency:STEP:AUTO
OFF | ON | 0 | 1 , OFF | ON | 0 | 1 , OFF | ON | 0 | 1 , OFF | ON | 0 | 1 , OFF | ON | 0 | 1
```

```
[ :SENSe ] :SEMAsk:OFFSet [n] :LIST:FREQuency:STEP:AUTO?
```

1xEV-DO mode

```
[ :SENSe ] :SEMAsk:OFFSet:LIST[m] :FREQuency:STEP:AUTO
OFF | ON | 0 | 1 , OFF | ON | 0 | 1 , OFF | ON | 0 | 1 , OFF | ON | 0 | 1 , OFF | ON | 0 | 1
```

```
[ :SENSe ] :SEMAsk:OFFSet:LIST[m] :FREQuency:STEP:AUTO?
```

Set the auto mode to determine the offset step frequency to On or Off.

SENSe Subsystem

OFF - enter a value to set the step frequency for an offset channel, referring to [:SENS]:SEM:OFFS[n]:LIST[m]:FREQ:STEP.

ON - the step frequency for an offset channel is automatically set according to the offset start and stop frequencies.

OFFSet[n] n=1 is the base station test and n=2 is the mobile test. The default is the base station test (1). (cdma2000, W-CDMA mode only)

LIST[m] m=1 is the spectrum emission mask (SEM) mode and m=2 is the adjacent channel power (ACP) mode. The default is the SEM mode (1). (1xEV-DO mode only)

Factory Preset:

Mode	Variant	Offset A	Offset B	Offset C	Offset D	Offset E
cdma2000		ON	ON	ON	ON	ON
W-CDMA		ON	ON	ON	ON	ON
1xEV-DO	SEM	ON	ON	ON	ON	ON
	ACP	ON	ON	ON	ON	ON

Remarks: You must be in cdma2000, W-CDMA, or 1xEV-DO mode to use this command. Use INSTRument:SElect to set the mode.

Spectrum Emission Mask—Offset Stop Frequency

cdma2000, W-CDMA mode

```
[ :SENSe ] :SEMAsk :OFFSet [ n ] :LIST :FREQUency :STOP
<f_offset> , <f_offset> , <f_offset> , <f_offset> , <f_offset>
```

```
[ :SENSe ] :SEMAsk :OFFSet [ n ] :LIST :FREQUency :STOP?
```

1xEV-DO mode

```
[ :SENSe ] :SEMAsk :OFFSet :LIST [ m ] :FREQUency :STOP
<f_offset> , <f_offset> , <f_offset> , <f_offset> , <f_offset>
```

```
[ :SENSe ] :SEMAsk :OFFSet :LIST [ m ] :FREQUency :STOP?
```

Sets the five (5) sets of the offset stop frequencies.

OFFSet[n] n=1 is the base station test and n=2 is the mobile test. The default is the base station test (1). (cdma2000, W-CDMA mode only)

LIST[m] m=1 is the spectrum emission mask (SEM) mode and m=2 is the adjacent channel power (ACP) mode. The default is the SEM mode (1). (1xEV-DO mode only)

Factory Preset:

Mode	Variant	Offset A	Offset B	Offset C	Offset D	Offset E
cdma2000	BTS	795.0 kHz	1.195 MHz	4.015 MHz	4.0031 MHz	12.50 MHz
	MS	1.995 MHz	4.015 MHz	4.0031 MHz	12.00 MHz	15.00 MHz
W-CDMA	BTS	2.715 MHz	3.515 MHz	4.000 MHz	8.000 MHz	12.50 MHz
	MS	3.485 MHz	7.500 MHz	8.500 MHz	12.00 MHz	15.00 MHz
1xEV-DO	SEM	795.0 kHz	1.995 MHz	4.015 MHz	4.0031 MHz	12.50 MHz
	ACP	765.0 kHz	1.995 MHz	3.125 MHz	4.000 MHz	7.500 MHz

Range: 10.0 kHz to 100.0 MHz

Default Unit: Hz

Remarks: You must be in the cdma2000, W-CDMA, or 1xEV-DO mode to use this command. Use INSTRUMENT:SElect to set the mode.

Spectrum Emission Mask—Offset Relative Attenuation*cdma2000, W-CDMA mode*

```
[ :SENSe ] : SEMask : OFFSet [ n ] : LIST : RATTenuation
<rel_power> , <rel_power> , <rel_power> , <rel_power> , <rel_power>
```

```
[ :SENSe ] : SEMask : OFFSet [ n ] : LIST : RATTenuation?
```

1xEV-DO mode

```
[ :SENSe ] : SEMask : OFFSet : LIST [ m ] : RATTenuation
<rel_power> , <rel_power> , <rel_power> , <rel_power> , <rel_power>
```

```
[ :SENSe ] : SEMask : OFFSet : LIST [ m ] : RATTenuation?
```

Set a relative amount of attenuation for the measurements made at an offset channel. The amount is specified relative to the attenuation required to measure the carrier channel. Since the offset channel power is lower than the carrier channel power, less attenuation is required to measure the offset channel and you get wider dynamic range for the measurement.

You can turn off (not use) specific offset channels with
[:SENS]:SEM:OFFS[n]:LIST[m]:STAT.

OFFSet[n] n=1 is the base station test and n=2 is the mobile test. The default is the base station test (1). (cdma2000, W-CDMA mode only)

LIST[m] m=1 is the spectrum emission mask (SEM) mode and m=2 is the adjacent channel power (ACP) mode. The default is the SEM mode (1). (1xEV-DO mode only)

SENSe Subsystem

Factory Preset:

Mode	Offset A	Offset B	Offset C	Offset D	Offset E
cdma2000	0.00 dB	0.00 dB	0.00 dB	0.00 dB	0.00 dB
W-CDMA	0.00 dB	0.00 dB	0.00 dB	0.00 dB	0.00 dB
1xEV-DO	0.00 dB	0.00 dB	0.00 dB	0.00 dB	0.00 dB

Range: –40.00 to 0.00 dB, but this relative attenuation cannot exceed the absolute attenuation ranging from 0 to 40 dB.

Default Unit: dB

Remarks: Remember that the attenuation that you specify is always relative to the amount of attenuation used for the carrier channel. Selecting negative attenuation means that you want less attenuation used. For example, if the measurement must use 20 dB of attenuation for the carrier measurement and you want to use 12 dB less attenuation for the first offset, you would send the value –12 dB.

You must be in the cdma2000, W-CDMA, or 1xEV-DO mode to use this command. Use INSTRument:SElect to set the mode.

Spectrum Emission Mask—Offset Frequency Side

cdma2000, W-CDMA mode

```
[ :SENSe ] :SEMAsk :OFFSet [n] :LIST :SIDE BOTH | NEGative | POSitive ,
BOTH | NEGative | POSitive , BOTH | NEGative | POSitive ,
BOTH | NEGative | POSitive , BOTH | NEGative | POSitive
```

```
[ :SENSe ] :SEMAsk :OFFSet [n] :LIST :SIDE ?
```

1xEV-DO mode

```
[ :SENSe ] :SEMAsk :OFFSet :LIST [m] :SIDE BOTH | NEGative | POSitive ,
BOTH | NEGative | POSitive , BOTH | NEGative | POSitive ,
BOTH | NEGative | POSitive , BOTH | NEGative | POSitive
```

```
[ :SENSe ] :SEMAsk :OFFSet :LIST [m] :SIDE ?
```

Specify which sideband will be measured. You can turn off (not use) specific offsets with [:SENS]:SEM:OFFS[n]:LIST[m]:STAT.

BOTH - both of the negative (lower) and positive (upper) sidebands

NEGative - negative (lower) sideband only

POSitive - positive (upper) sideband only

OFFSet[n] n=1 is the base station test and n=2 is the mobile test. The default is the base station test (1). (cdma2000, W-CDMA mode)

only)

LIST[m] m=1 is the spectrum emission mask (SEM) mode and m=2 is the adjacent channel power (ACP) mode. The default is the SEM mode (1). (1xEV-DO mode only)

Factory Preset:

Mode	Variant	Offset A	Offset B	Offset C	Offset D	Offset E
cdma2000		BOTH	BOTH	BOTH	BOTH	BOTH
W-CDMA		BOTH	BOTH	BOTH	BOTH	BOTH
1xEV-DO	SEM	BOTH	BOTH	BOTH	BOTH	BOTH
	ACP	BOTH	BOTH	BOTH	BOTH	BOTH

Remarks: You must be in the cdma2000, W-CDMA, or 1xEV-DO mode to use this command. Use INSTRument:SElect to set the mode.

Spectrum Emission Mask—Offset Start Absolute Power Limit

cdma2000, W-CDMA mode

```
[ :SENSe ] : SEMask : OFFSet [ n ] : LIST : START : ABSolute
<abs_power> , <abs_power> , <abs_power> , <abs_power> , <abs_power>
```

```
[ :SENSe ] : SEMask : OFFSet [ n ] : LIST : START : ABSolute ?
```

1xEV-DO mode

```
[ :SENSe ] : SEMask : OFFSet : LIST [ m ] : START : ABSolute
<abs_power> , <abs_power> , <abs_power> , <abs_power> , <abs_power>
```

```
[ :SENSe ] : SEMask : OFFSet : LIST [ M ] : START : ABSolute ?
```

Sets an absolute power level for each offset start limit. The list must contain five (5) entries. If there is more than one offset, the offset closest to the carrier channel comes first in the list.

The fail condition for each offset channel is set by
[:SENS]:SEM:OFFS[n]:LIST[m]:TEST.

You can turn off (not use) specific offset channels with
[:SENS]:SEM:OFFS[n]:LIST[m]:STAT.

The query returns the five (5) sets of the real values currently set to the absolute power test limits.

OFFSet[n] n=1 is the base station test and n=2 is the mobile test. The default is the base station test (1). (cdma2000, W-CDMA mode only)

LIST[m] m=1 is the spectrum emission mask (SEM) mode and m=2 is the

SENSe Subsystem

adjacent channel power (ACP) mode. The default is the SEM mode (1). (1xEV-DO mode only)

Factory Preset:

Mode	Variant	Offset A	Offset B	Offset C	Offset D	Offset E
cdma2000	BTS	-27.0 dBm	-27.0 dBm	-27.0 dBm	-46.00 dBm	-13.00 dBm
	MS	-70.13 dBm	-70.13 dBm	-35.00 dBm	-13.00 dBm	-13.00 dBm
W-CDMA	BTS	-12.50 dBm	-12.50 dBm	-24.50 dBm	-11.50 dBm	-11.50 dBm
	MS	-69.57 dBm	-54.34 dBm	-54.34 dBm	-54.34 dBm	-54.34 dBm
1xEV-DO	SEM	-27.00 dBm	-27.00 dBm	-27.00 dBm	-46.00 dBm	-13.00 dBm
	ACP	-27.00 dBm	-27.00 dBm	-13.00 dBm	-13.00 dBm	-13.00 dBm

Range: -200.0 dBm to 50.0 dBm

Default Unit: dBm

Remarks: You must be in the cdma2000, W-CDMA, or 1xEV-DO mode to use this command. Use INSTRument:SElect to set the mode.

Spectrum Emission Mask—Offset Start Relative Power Limit

cdma2000, W-CDMA mode

```
[ :SENSe ] :SEMAsk :OFFSet [ n ] :LIST :START :RCARrier  
<rel_power> , <rel_power> , <rel_power> , <rel_power> , <rel_power>
```

```
[ :SENSe ] :SEMAsk :OFFSet [ n ] :LIST :START :RCARrier?
```

1xEV-DO mode

```
[ :SENSe ] :SEMAsk :OFFSet :LIST [ m ] :START :RCARrier  
<rel_power> , <rel_power> , <rel_power> , <rel_power> , <rel_power>
```

```
[ :SENSe ] :SEMAsk :OFFSet :LIST [ m ] :START :RCARrier?
```

Set a relative power level for each offset start limit. The list must contain five (5) entries. If there is more than one offset, the offset closest to the carrier channel comes first in the list.

The fail condition is set by [:SENS]:SEM:OFFS[n]:LIST[m]:TEST for each offset channel test.

You can turn off (not use) specific offset channels with [:SENS]:SEM:OFFS[n]:LIST[m]:STAT.

The query returns the five (5) sets of the real values currently set to the relative power test limits.

OFFSet[n] n=1 is the base station test and n=2 is the mobile test. The

default is the base station test (1). (cdma2000, W-CDMA mode only)

LIST[m] m=1 is the spectrum emission mask (SEM) mode and m=2 is the adjacent channel power (ACP) mode. The default is the SEM mode (1). (1xEV-DO mode only)

Factory Preset:

Mode	Variant	Offset A	Offset B	Offset C	Offset D	Offset E
cdma2000	BTS	-45.00 dB	-45.00 dB	-55.00 dB	-55.00 dB	-55.00 dB
	MS	-42.00 dB	-54.00 dB	-54.00 dB	-54.00 dB	-54.00 dB
W-CDMA	BTS	-30.00 dB	-30.00 dB	-30.00 dB	-30.00 dB	-30.00 dB
	MS	-33.73 dB	-34.00 dB	-37.50 dB	-47.50 dB	-47.50 dB
1xEV-DO	SEM	-45.00 dB	-45.00 dB	-55.00 dB	-55.00 dB	-55.00 dB
	ACP	-45.00 dB	-55.00 dB	-55.00 dB	-55.00 dB	-55.00 dB

Range: -150.0 dBm to 50.0 dB

Default Unit: dB

Remarks: You must be in the cdma2000, W-CDMA, or 1xEV-DO mode to use this command. Use INSTRument:SElect to set the mode.

Spectrum Emission Mask—Offset Measurement State

cdma2000, W-CDMA mode

```
[ :SENSe ] : SEMask : OFFSet [ n ] : LIST : STATE
OFF | ON | 0 | 1 , OFF | ON | 0 | 1 , OFF | ON | 0 | 1 , OFF | ON | 0 | 1 , OFF | ON | 0 | 1
```

```
[ :SENSe ] : SEMask : OFFSet [ n ] : LIST : STATE?
```

1xEV-DO mode

```
[ :SENSe ] : SEMask : OFFSet : LIST [ m ] : STATE
OFF | ON | 0 | 1 , OFF | ON | 0 | 1 , OFF | ON | 0 | 1 , OFF | ON | 0 | 1 , OFF | ON | 0 | 1
```

```
[ :SENSe ] : SEMask : OFFSet : LIST [ m ] : STATE?
```

Define whether or not to execute pass/fail tests at the offset channels. The pass/fail conditions are set by [:SENS]:SEM:OFFS[n]:LIST[m]:ABS or [:SENS]:SEM:OFFS[n]:LIST[m]:RCAR for each offset channel.

OFFSet[n] n=1 is the base station test and n=2 is the mobile test. The default is the base station test (1). (cdma2000, W-CDMA mode only)

LIST[m] m=1 is the spectrum emission mask (SEM) mode and m=2 is the adjacent channel power (ACP) mode. The default is the SEM

SENSe Subsystem

mode (1). (1xEV-DO mode only)

Factory Preset:

Mode	Variant	Offset A	Offset B	Offset C	Offset D	Offset E
cdma2000	BTS	ON	ON	ON	OFF	OFF
	MS	ON	ON	OFF	OFF	OFF
W-CDMA	BTS	ON	ON	ON	ON	ON
	MS	ON	ON	ON	ON	OFF
1xEV-DO	SEM	ON	ON	ON	OFF	OFF
	ACP	ON	ON	OFF	OFF	OFF

Remarks: You must be in the cdma2000, W-CDMA, or 1xEV-DO mode to use this command. Use INSTRUMENT:SELEct to set the mode.

Spectrum Emission Mask—Offset Stop Absolute Power Limit

cdma2000, W-CDMA mode

```
[ :SENSe ] :SEMAsk:OFFSet[n]:LIST:STOP:ABSolute  
<abs_power>,<abs_power>,<abs_power>,<abs_power>,<abs_power>
```

```
[ :SENSe ] :SEMAsk:OFFSet[n]:LIST:STOP:ABSolute?
```

1xEV-DO. mode

```
[ :SENSe ] :SEMAsk:OFFSet:LIST[m]:STOP:ABSolute  
<abs_power>,<abs_power>,<abs_power>,<abs_power>,<abs_power>
```

```
[ :SENSe ] :SEMAsk:OFFSet:LIST[m]:STOP:ABSolute?
```

Set an absolute power level to for each offset stop limit. The list must contain five (5) entries. If there is more than one offset, the offset closest to the carrier channel comes first in the list.

The fail condition is set by [:SENS]:SEM:OFFS[n]:LIST[m]:TEST for each offset channel test.

You can turn off (not use) specific offset channels with [:SENS]:SEM:OFFS[n]:LIST[m]:STAT.

The query returns the five (5) sets of the real values currently set to the offset stop absolute power limits.

OFFSet[n] n=1 is the base station test and n=2 is the mobile test. The default is the base station test (1). (cdma2000, W-CDMA mode only)

LIST[m] m=1 is the spectrum emission mask (SEM) mode and m=2 is the adjacent channel power (ACP) mode. The default is the SEM

mode (1). (1xEV-DO mode only)

Factory Preset:

Mode	Variant	Offset A	Offset B	Offset C	Offset D	Offset E
cdma2000	BTS	-27.00 dBm	-27.00 dBm	-27.00 dBm	-46.00 dBm	-13.00 dBm
	MS	-70.13 dBm	-70.13 dBm	-35.00 dBm	-13.00 dBm	-13.00 dBm
W-CDMA	BTS	-12.50 dBm	-24.50 dBm	-24.50 dBm	-11.50 dBm	-11.50 dBm
	MS	-69.57 dBm	-54.34 dBm	-54.34 dBm	-54.34 dBm	-54.34 dBm
1xEV-DO	SEM	-27.00 dBm	-27.00 dBm	-27.00 dBm	-46.00 dBm	-13.00 dBm
	ACP	-27.00 dBm	-27.00 dBm	-13.00 dBm	-13.00 dBm	-13.00 dBm

Range: -200.0 dBm to 50.0 dBm

Default Unit: dBm

Remarks: You must be in the cdma2000, W-CDMA, or 1xEV-DO mode to use this command. Use INSTRument:SElect to set the mode.

Spectrum Emission Mask—Couple Offset Stop Absolute Power Limit

cdma2000, W-CDMA mode

```
[ :SENSe ] :SEMAsk:OFFSet[n] :LIST:STOP:ABSolute:COUPLE
OFF | ON | 0 | 1 , OFF | ON | 0 | 1 , OFF | ON | 0 | 1 , OFF | ON | 0 | 1 , OFF | ON | 0 | 1
```

```
[ :SENSe ] :SEMAsk:OFFSet[n] :LIST:STOP:ABSolute:COUPLE?
```

1xEV-DO mode

```
[ :SENSe ] :SEMAsk:OFFSet:LIST[m] :STOP:ABSolute:COUPLE
OFF | ON | 0 | 1 , OFF | ON | 0 | 1 , OFF | ON | 0 | 1 , OFF | ON | 0 | 1 , OFF | ON | 0 | 1
```

```
[ :SENSe ] :SEMAsk:OFFSet:LIST[m] :STOP:ABSolute:COUPLE?
```

Define whether or not to couple the offset stop absolute power limit to the offset start absolute power limit for each offset channel.

You can turn off (not use) specific offset channels with
[:SENS]:SEM:OFFS[n]:LIST[m]:STAT.

OFFSet[n] n=1 is the base station test and n=2 is the mobile test. The default is the base station test (1). (cdma2000, W-CDMA mode only)

LIST[m] m=1 is the spectrum emission mask (SEM) mode and m=2 is the adjacent channel power (ACP) mode. The default is the SEM mode (1). (1xEV-DO mode only)

SENSe Subsystem

Factory Preset:

Mode	Variant	Offset A	Offset B	Offset C	Offset D	Offset E
cdma2000	BTS	ON	ON	ON	ON	ON
	MS	ON	ON	ON	ON	ON
W-CDMA	BTS	ON	OFF	ON	ON	ON
	MS	ON	ON	ON	ON	ON
1xEV-DO	SEM	ON	ON	ON	ON	ON
	ACP	ON	ON	ON	ON	ON

Remarks: You must be in the cdma2000, W-CDMA, or 1xEV-DO mode to use this command. Use INSTRument:SElect to set the mode.

Spectrum Emission Mask—Offset Stop Relative Power Limit

cdma2000, W-CDMA mode

```
[ :SENSe ] :SEMAsk :OFFSet [ n ] :LIST :STOP :RCARrier  
<rel_power> , <rel_power> , <rel_power> , <rel_power> , <rel_power>
```

```
[ :SENSe ] :SEMAsk :OFFSet [ n ] :LIST :STOP :RCARrier?
```

1xEV-DO mode

```
[ :SENSe ] :SEMAsk :OFFSet :LIST [ m ] :STOP :RCARrier  
<rel_power> , <rel_power> , <rel_power> , <rel_power> , <rel_power>
```

```
[ :SENSe ] :SEMAsk :OFFSet :LIST [ m ] :STOP :RCARrier?
```

Set a relative power level for each offset stop limit. The list must contain five (5) entries. If there is more than one offset, the offset closest to the carrier channel comes first in the list.

The fail condition is set by [:SENS]:SEM:OFFS[n]:LIST[m]:TEST for each offset channel.

You can turn off (not use) specific offset channels with [:SENS]:SEM:OFFS[n]:LIST[m]:STAT.

The query returns the five (5) sets of the real values currently set to the offset stop relative power limits.

OFFSet[n] n=1 is the base station test and n=2 is the mobile test. The default is the base station test (1). (cdma2000, W-CDMA mode only)

LIST[m] m=1 is the spectrum emission mask (SEM) mode and m=2 is the adjacent channel power (ACP) mode. The default is the SEM mode (1). (1xEV-DO mode only)

Factory Preset:

Mode	Variant	Offset A	Offset B	Offset C	Offset D	Offset E
cdma2000	BTS	-45.00 dB	-45.00 dB	-55.00 dB	-55.00 dB	-55.00 dB
	MS	-42.00 dB	-54.00 dB	-54.00 dB	-54.00 dB	-54.00 dB
W-CDMA	BTS	-30.00 dB	-30.00 dB	-30.00 dB	-30.00 dB	-30.00 dB
	MS	-48.28 dB	-37.50 dB	-47.50 dB	-47.50 dB	-47.50 dB
1xEV-DO	SEM	-45.00 dB	-45.00 dB	-55.00 dB	-55.00 dB	-55.00 dB
	ACP	-45.00 dB	-55.00 dB	-55.00 dB	-55.00 dB	-55.00 dB

Range: -150.0 dBm to 50.0 dB

Default Unit: dB

Remarks: You must be in the cdma2000, W-CDMA, or 1xEV-DO mode to use this command. Use INSTRUMENT:SElect to set the mode.

Spectrum Emission Mask—Couple Offset Stop Relative Power Limit

cdma2000, W-CDMA mode

```
[ :SENSe ] : SEMask : OFFSet [ n ] : LIST : STOP : RCARrier : COUPLE
OFF | ON | 0 | 1 , OFF | ON | 0 | 1 , OFF | ON | 0 | 1 , OFF | ON | 0 | 1 , OFF | ON | 0 | 1
```

```
[ :SENSe ] : SEMask : OFFSet [ n ] : LIST : STOP : RCARrier : COUPLE ?
```

1xEV-DO mode

```
[ :SENSe ] : SEMask : OFFSet : LIST [ m ] : STOP : RCARrier : COUPLE
OFF | ON | 0 | 1 , OFF | ON | 0 | 1 , OFF | ON | 0 | 1 , OFF | ON | 0 | 1 , OFF | ON | 0 | 1
```

```
[ :SENSe ] : SEMask : OFFSet : LIST [ m ] : STOP : RCARrier : COUPLE ?
```

Define whether or not to couple the offset stop relative power limit to the offset start relative power limit for each offset channel.

You can turn off (not use) specific offset channels with
[:SENS]:SEM:OFFS[n]:LIST[m]:STAT.

OFFSet[n] n=1 is the base station test and n=2 is the mobile test. The default is the base station test (1). (cdma2000, W-CDMA mode only)

LIST[m] m=1 is the spectrum emission mask (SEM) mode and m=2 is the adjacent channel power (ACP) mode. The default is the SEM mode (1). (1xEV-DO mode only)

SENSE Subsystem

Factory Preset:

Mode	Variant	Offset A	Offset B	Offset C	Offset D	Offset E
cdma2000	BTS	ON	ON	ON	ON	ON
	MS	ON	ON	ON	ON	ON
W-CDMA	BTS	ON	ON	ON	ON	ON
	MS	OFF	OFF	OFF	ON	ON
1xEV-DO	SEM	ON	ON	ON	ON	ON
	ACP	ON	ON	ON	ON	ON

Remarks: You must be in the cdma2000, W-CDMA, or 1xEV-DO mode to use this command. Use INSTRUMENT:SELEct to set the mode.

Spectrum Emission Mask—Offset Channel Fail Condition

cdma2000, W-CDMA mode

```
[ :SENSE ] :SEMAsk:OFFSet[n]:LIST:TEST
ABSolute |AND| OR |RELAtive,ABSolute |AND| OR |RELAtive,
ABSolute |AND| OR |RELAtive,ABSolute |AND| OR |RELAtive,
ABSolute |AND| OR |RELAtive
```

```
[ :SENSE ] :SEMAsk:OFFSet[n]:LIST:TEST?
```

1xEV-DO mode

```
[ :SENSE ] :SEMAsk:OFFSet:LIST[m]:TEST
ABSolute |AND| OR |RELAtive,ABSolute |AND| OR |RELAtive,
ABSolute |AND| OR |RELAtive,ABSolute |AND| OR |RELAtive,
ABSolute |AND| OR |RELAtive
```

```
[ :SENSE ] :SEMAsk:OFFSet:LIST[m]:TEST?
```

Define one of the fail conditions for each offset channel limit test to be done. The absolute or relative power limit value for each offset channel is set by [:SENS]:SEM:OFFS[n]:LIST[m]:ABS or [:SENS]:SEM:OFFS[n]:LIST[m]:RCAR.

You can turn off (not use) specific offset channels with [:SENS]:SEM:OFFS[n]:LIST[m]:STAT.

OFFSet[n] n=1 is the base station test and n=2 is the mobile test. The default is the base station test (1). (cdma2000, W-CDMA mode only)

LIST[m] m=1 is the spectrum emission mask (SEM) mode and m=2 is the adjacent channel power (ACP) mode. The default is the SEM mode (1). (1xEV-DO mode only)

The fail condition that can be set for each offset channel include:

- **AND** - Tests the measurement result for an offset channel against both the absolute power limit and the relative power limit. If it fails, then returns a failure for that measurement test.
- **ABSolute** - Tests the measurement result for an offset channel against the absolute power limit. If it fails, then returns a failure for that measurement test.
- **OR** - Tests the measurement result for an offset channel against the absolute power limit OR the relative power limit. If either test fails, then returns a failure for that measurement test.
- **RELative** - Tests the measurement result for an offset channel against the relative power limit. If it fails, then returns a failure for that measurement test.

Factory Preset:

Mode	Variant	Offset A	Offset B	Offset C	Offset D	Offset E
cdma2000	BTS	REL	REL	REL	ABS	REL
	MS	AND	AND	ABS	REL	REL
W-CDMA	BTS	ABS	ABS	ABS	ABS	ABS
	MS	AND	AND	AND	AND	AND
1xEV-DO	SEM	REL	REL	REL	ABS	REL
	ACP	REL	REL	ABS	REL	REL

Remarks: You must be in the cdma2000, W-CDMA, or 1xEV-DO mode to use this command. Use INSTRUMENT:SElect to set the mode.

Spectrum Emission Mask—Region Resolution Bandwidth

cdma2000, W-CDMA mode

```
[ :SENSe ] : SEMask : REGion [ n ] : LIST : BANDwidth | BWIDth
< res_bw > , < res_bw > , < res_bw > , < res_bw > , < res_bw >
```

```
[ :SENSe ] : SEMask : REGion [ n ] : LIST : BANDwidth | BWIDth?
```

1xEV-DO mode

```
[ :SENSe ] : SEMask : REGion : LIST : BANDwidth | BWIDth
< res_bw > , < res_bw > , < res_bw > , < res_bw > , < res_bw >
```

```
[ :SENSe ] : SEMask : REGion : LIST : BANDwidth | BWIDth?
```

Define the region resolution bandwidth(s) for spectrum emission measurements. The list must contain five (5) entries. You can turn off (not use) specific regions with [:SENS]:SEM:REG[n]:LIST:STAT.

REGion[n] n=1 is the base station test and n=2 is the mobile test. The

SENSe Subsystem

default is the base station test (1). (cdma2000, W-CDMA mode only)

Factory Preset
and *RST: Auto coupled, except cdma2000, see below.

Mode	Variant	Region A	Region B	Region C	Region D	Region E
cdma2000	BTS	1.000 MHz	300.0 kHz	100.0 kHz	100.0 kHz	4.000 MHz
	MS	300.0 kHz	100.0 kHz	100.0 kHz	100.0 kHz	12.00 MHz

Range: 300 Hz to 7.5 MHz

Default Unit: Hz

Remarks: You must be in the cdma2000, W-CDMA, or 1xEV-DO mode to use this command. Use INSTRument:SELEct to set the mode.

Spectrum Emission Mask—Auto Region Resolution Bandwidth

cdma2000, W-CDMA mode

```
[ :SENSe ] :SEMAsk:REGIon[n]:LIST:BA NDwidth|BWIDth:AUTO  
OFF|ON|0|1,OFF|ON|0|1,OFF|ON|0|1,OFF|ON|0|1,OFF|ON|0|1
```

```
[ :SENSe ] :SEMAsk:REGIon[n]:LIST:BA NDwidth|BWIDth:AUTO?
```

1xEV-DO mode

```
[ :SENSe ] :SEMAsk:REGIon:LIST:BA NDwidth|BWIDth:AUTO  
OFF|ON|0|1,OFF|ON|0|1,OFF|ON|0|1,OFF|ON|0|1,OFF|ON|0|1
```

```
[ :SENSe ] :SEMAsk:REGIon:LIST:BA NDwidth|BWIDth:AUTO?
```

Set the auto mode of the region step frequency.

Set the auto mode to determine the region resolution bandwidth to On or Off.

OFF - enter a value to set the resolution bandwidth for a region channel, referring to [:SENS]:SEM:REG[n]:LIST:BAND|BWID.

ON - the resolution bandwidth for a region channel is automatically set according to the region start and stop frequencies.

REGIon[n] n=1 is the base station test and n=2 is the mobile test. The default is the base station test (1). (cdma2000, W-CDMA mode only)

Factory Preset and *RST:

Mode	Region A	Region B	Region C	Region D	Region E
cdma2000	OFF	OFF	OFF	OFF	OFF

Mode	Region A	Region B	Region C	Region D	Region E
W-CDMA	ON	ON	ON	ON	ON
1xEV-DO	ON	ON	ON	ON	ON

Remarks: You must be in the cdma2000, W-CDMA, or 1xEV-DO mode to use this command. Use INSTRument:SElect to set the mode.

Spectrum Emission Mask—Region Start Frequency

cdma2000, W-CDMA mode

```
[ :SENSe ] :SEMAsk:REGion[n] :LIST:FREQuency:START
<f_region>,<f_region>,<f_region>,<f_region>,<f_region>
```

```
[ :SENSe ] :SEMAsk:REGion[n] :LIST:FREQuency:START?
```

1xEV-DO mode

```
[ :SENSe ] :SEMAsk:REGion:LIST:FREQuency:START
<f_region>,<f_region>,<f_region>,<f_region>,<f_region>
```

```
[ :SENSe ] :SEMAsk:REGion:LIST:FREQuency:START?
```

Set the five (5) sets of the region start frequencies.

REGion[n] n=1 is the base station test and n=2 is the mobile test. The default is the base station test (1). (cdma2000, W-CDMA mode only)

Factory Preset and *RST:

Mode	Variant	Region A	Region B	Region C	Region D	Region E
cdma2000	BTS	1920.5 MHz	1893.65 MHz	876.05 MHz	921.05 MHz	800.0 MHz
	MS	1920.5 MHz	925.05 MHz	935.05 MHz	1805.05 MHz	800.0 MHz
W-CDMA	n/a	1920.0 MHz	1893.5 MHz	2100.0 MHz	2175.0 MHz	800.0 MHz
1xEV-DO	n/a	1920.0 MHz	1893.5 MHz	2100.0 MHz	2175.0 MHz	800.0 MHz

Range: 329.0 MHz to 3.678 GHz

Default Unit: Hz

Remarks: You must be in the cdma2000, W-CDMA, or 1xEV-DO mode to use this command. Use INSTRument:SElect to set the mode.

Spectrum Emission Mask—Region Step Frequency

cdma2000, W-CDMA mode

SENSe Subsystem

```
[ :SENSe ] :SEMask:REGion[n]:LIST:FREQuency:STEP  
<f_region>,<f_region>,<f_region>,<f_region>,<f_region>
```

```
[ :SENSe ] :SEMask:REGion[n]:LIST:FREQuency:STEP?
```

1xEV-DO mode

```
[ :SENSe ] :SEMask:REGion:LIST:FREQuency:STEP  
<f_region>,<f_region>,<f_region>,<f_region>,<f_region>
```

```
[ :SENSe ] :SEMask:REGion:LIST:FREQuency:STEP?
```

Sets the five (5) sets of the region step frequencies.

REGion[n] n=1 is the base station test and n=2 is the mobile test. The default is the base station test (1). (cdma2000, W-CDMA mode only)

Factory Preset: No valid value as the default is set to Auto. See [:SENS]:SEM:REG[n]:LIST:FREQ:STEP:AUTO.

Range: 100 Hz to 7.5 MHz

The minimum value is determined to be equal to or greater than one 2000th (1/2000) of the frequency difference derived from (Stop Freq – Start Freq).

Default Unit: Hz

Remarks: You must be in the cdma2000, W-CDMA, or 1xEV-DO mode to use this command. Use INSTRument:SELEct to set the mode.

Spectrum Emission Mask—Auto Region Step Frequency

cdma2000, W-CDMA mode

```
[ :SENSe ] :SEMask:REGion[n]:LIST:FREQuency:STEP:AUTO  
OFF|ON|0|1,OFF|ON|0|1,OFF|ON|0|1,OFF|ON|0|1,OFF|ON|0|1
```

```
[ :SENSe ] :SEMask:REGion[n]:LIST:FREQuency:STEP:AUTO?
```

1xEV-DO mode

```
[ :SENSe ] :SEMask:REGion:LIST:FREQuency:STEP:AUTO  
OFF|ON|0|1,OFF|ON|0|1,OFF|ON|0|1,OFF|ON|0|1,OFF|ON|0|1
```

```
[ :SENSe ] :SEMask:REGion:LIST:FREQuency:STEP:AUTO?
```

Set the auto mode to determine the region step frequency to On or Off.

OFF - enter a value to set the step frequency for a region channel, referring to [:SENS]:SEM:REG[n]:LIST:FREQ:STEP.

ON - the step frequency for a region channel is automatically set according to the region start and stop frequencies.

REGion[n] n=1 is the base station test and n=2 is the mobile test. The

default is the base station test (1). (cdma2000, W-CDMA mode only)

Factory Preset:

Mode	Region A	Region B	Region C	Region D	Region E
cdma2000	ON	ON	ON	ON	ON
W-CDMA	ON	ON	ON	ON	ON
1xEV-DO	ON	ON	ON	ON	ON

Remarks: You must be in the cdma2000, W-CDMA, or 1xEV-DO mode to use this command. Use INSTRUMENT:SElect to set the mode.

Spectrum Emission Mask—Region Stop Frequency

cdma2000, W-CDMA mode

```
[ :SENSE ] :SEMask:REGion[n] :LIST:FREQuency:STOP
<f_region>,<f_region>,<f_region>,<f_region>,<f_region>
```

```
[ :SENSE ] :SEMask:REGion[n] :LIST:FREQuency:STOP?
```

1xEV-DO mode

```
[ :SENSE ] :SEMask:REGion:LIST:FREQuency:STOP
<f_region>,<f_region>,<f_region>,<f_region>,<f_region>
```

```
[ :SENSE ] :SEMask:REGion:LIST:FREQuency:STOP?
```

Sets the five (5) sets of the region stop frequencies.

REGion[n] n=1 is the base station test and n=2 is the mobile test. The default is the base station test (1). (cdma2000, W-CDMA mode only)

Factory Preset and *RST:

Mode	Variant	Region A	Region B	Region C	Region D	Region E
cdma2000	BTS	1980.5 MHz	1919.75 MHz	915.05 MHz	960.05 MHz	1000.0 MHz
	MS	1980.5 MHz	935.05 MHz	960.05 MHz	1880.05 MHz	1000.0 MHz
W-CDMA	n/a	1980.0 MHz	1919.6 MHz	2105.0 MHz	2180.0 MHz	1000.0 MHz
1xEV-DO	n/a	1980.0 MHz	1919.6 MHz	2105.0 MHz	2180.0 MHz	1000.0 MHz

Range: 329.0 MHz to 3.678 MHz

Default Unit: Hz

Remarks: You must be in the cdma2000, W-CDMA, or 1xEV-DO mode to use this command. Use INSTRUMENT:SElect to set the mode.

SENSe Subsystem

Spectrum Emission Mask—Region Relative Attenuation

cdma2000, W-CDMA mode

```
[ :SENSe ] :SEMAsk:REGion[n]:LIST:RATTenuation
<rel_power>,<rel_power>,<rel_power>,<rel_power>,<rel_power>
```

```
[ :SENSe ] :SEMAsk:REGion[n]:LIST:RATTenuation?
```

1xEV-DO mode

```
[ :SENSe ] :SEMAsk:REGion:LIST:RATTenuation
<rel_power>,<rel_power>,<rel_power>,<rel_power>,<rel_power>
```

```
[ :SENSe ] :SEMAsk:REGion:LIST:RATTenuation?
```

Set a relative amount of attenuation for measurements made at a region. The amount is specified relative to the attenuation required to measure the carrier channel power. Since the region channel power is lower than the carrier channel power, less attenuation is required to measure the region channel and you get wider dynamic range for the measurement.

You can turn off (not use) specific regions with
[:SENS]:SEM:REG[n]:LIST:STAT.

REGion[n] n=1 is the base station test and n=2 is the mobile test. The default is the base station test (1). (cdma2000, W-CDMA mode only)

Factory Preset:

Mode	Variant	Region A	Region B	Region C	Region D	Region E
cdma2000	BTS	0.00 dB	0.00 dB	0.00 dB	0.00 dB	0.00 dB
	MS	0.00 dB	0.00 dB	0.00 dB	0.00 dB	0.00 dB
W-CDMA	n/a	0.00 dB	0.00 dB	0.00 dB	0.00 dB	0.00 dB
1xEV-DO	n/a	0.00 dB	0.00 dB	0.00 dB	0.00 dB	0.00 dB

Range: –40.00 to 0.00 dB, but this relative attenuation cannot exceed the absolute attenuation ranging from 0.00 to 40.00 dB.

Remarks: Remember that the attenuation that you specify is always relative to the amount of attenuation used for the carrier channel. Selecting negative attenuation means that you want less attenuation used. For example, if the measurement must use 20 dB of attenuation for the carrier measurement and you want to use 12 dB less attenuation for the first region, you would send the value –12 dB.

You must be in the cdma2000, W-CDMA, or 1xEV-DO mode to use this command. Use INSTRument:SELEct to set the mode.

Spectrum Emission Mask—Region Start Absolute Power Limit*cdma2000, W-CDMA (3GPP) mode*

```
[ :SENSe ] :SEMAsk:REGion[n] :LIST:STARt:ABSolute
<abs_power>, <abs_power>, <abs_power>, <abs_power>, <abs_power>
```

```
[ :SENSe ] :SEMAsk:REGion[n] :LIST:STARt:ABSolute?
```

1xEV-DO mode

```
[ :SENSe ] :SEMAsk:REGion:LIST:STARt:ABSolute
<abs_power>, <abs_power>, <abs_power>, <abs_power>, <abs_power>
```

```
[ :SENSe ] :SEMAsk:REGion:LIST:STARt:ABSolute?
```

Set an absolute power level for each region start limit. The list must contain five (5) entries. If there is more than one region, the region closest to the carrier channel comes first in the list.

The fail condition for each region channel is set by
[:SENS]:SEM:REG[n]:LIST:TEST.

You can turn off (not use) specific regions with
[:SENS]:SEM:REG[n]:LIST:STAT.

The query returns the five (5) sets of the real values currently set to the absolute power test limits.

REGion[n] n=1 is the base station test and n=2 is the mobile test. The default is the base station test (1). (cdma2000, W-CDMA mode only)

Factory Preset:

Mode	Variant	Region A	Region B	Region C	Region D	Region E
cdma2000	BTS	-86.00 dBm	-41.00 dBm	-98.00 dBm	-57.00 dBm	-50.00 dBm
	MS	-41.00 dBm	-67.00 dBm	-79.00 dBm	-71.00 dBm	-50.00 dBm
W-CDMA		-50.00 dBm	-50.00 dBm	-50.00 dBm	-50.00 dBm	-50.00 dBm
1xEV-DO		-50.00 dBm	-50.00 dBm	-50.00 dBm	-50.00 dBm	-50.00 dBm

Range: -200.00 dBm to 50.00 dBm

Default Unit: dBm

Remarks: You must be in the cdma2000, W-CDMA, or 1xEV-DO mode to use this command. Use INSTRument:SElect to set the mode.

SENSE Subsystem

Spectrum Emission Mask—Region Start Relative Power Limit

cdma2000, W-CDMA mode

```
[ :SENSE ] :SEMAsk:REGion[n]:LIST:START:RCARrier  
<rel_power>,<rel_power>,<rel_power>,<rel_power>,<rel_power>
```

```
[ :SENSE ] :SEMAsk:REGion[n]:LIST:START:RCARrier?
```

1xEV-DO mode

```
[ :SENSE ] :SEMAsk:REGion:LIST:START:RCARrier  
<rel_power>,<rel_power>,<rel_power>,<rel_power>,<rel_power>
```

```
[ :SENSE ] :SEMAsk:REGion:LIST:START:RCARrier?
```

Set a relative power level for each region start limit. The list must contain five (5) entries. If there is more than one region, the region closest to the carrier channel comes first in the list.

The fail condition is set by [:SENS]:SEM:REG[n]:LIST:TEST for each region test.

You can turn off (not use) specific regions with [:SENS]:SEM:REG[n]:LIST:STAT.

The query returns the five (5) sets of the real values currently set to the relative power test limits.

REGion[n] n=1 is the base station test and n=2 is the mobile test. The default is the base station test (1). (cdma2000, W-CDMA mode only)

Factory Preset:

Mode	Region A	Region B	Region C	Region D	Region E
cdma2000	-30.00 dB	-30.00 dB	-30.00 dB	-30.00 dB	-30.00 dB
W-CDMA	-30.00 dB	-30.00 dB	-30.00 dB	-30.00 dB	-30.00 dB
1xEV-DO	-30.00 dB	-30.00 dB	-30.00 dB	-30.00 dB	-30.00 dB

Range: -150.00 dBm to 50.00 dB

Default Unit: dB

Remarks: You must be in the cdma2000, W-CDMA, or 1xEV-DO mode to use this command. Use INSTRument:SELEct to set the mode.

Spectrum Emission Mask—Control Region List State

cdma2000, W-CDMA mode

```
[ :SENSE ] :SEMAsk:REGion[n]:LIST:STATE  
OFF | ON | 0 | 1, OFF | ON | 0 | 1, OFF | ON | 0 | 1, OFF | ON | 0 | 1, OFF | ON | 0 | 1
```

[:SENSe] :SEMAsk:REGion[n] :LIST:STATe?

1xEV-DO mode

[:SENSe] :SEMAsk:REGion:LIST:STATe

OFF | ON | 0 | 1, OFF | ON | 0 | 1, OFF | ON | 0 | 1, OFF | ON | 0 | 1, OFF | ON | 0 | 1

[:SENSe] :SEMAsk:REGion:LIST:STATe?

Define whether or not to execute pass/fail tests at custom region frequencies. The pass/fail conditions are set by [:SENS]:SEM:REG[n]:LIST:ABS or [:SENS]:SEM:REG[n]:LIST:RCAR for each region.

REGion[n] n=1 is the base station test and n=2 is the mobile test. The default is the base station test (1). (cdma2000, W-CDMA mode only)

Factory Preset and *RST:

Mode	Region A	Region B	Region C	Region D	Region E
cdma2000	ON	ON	OFF	OFF	OFF
W-CDMA	ON	ON	ON	OFF	OFF
1xEV-DO	ON	ON	ON	OFF	OFF

Remarks: You must be in the cdma2000, W-CDMA, or 1xEV-DO mode to use this command. Use INSTRument:SElect to set the mode.

Spectrum Emission Mask—Region Stop Absolute Power Limit

cdma2000, W-CDMA mode

[:SENSe] :SEMAsk:REGion[n] :LIST:STOP:ABSolute

<abs_power>, <abs_power>, <abs_power>, <abs_power>, <abs_power>

[:SENSe] :SEMAsk:REGion[n] :LIST:STOP:ABSolute?

1xEV-DO mode

[:SENSe] :SEMAsk:REGion:LIST:STOP:ABSolute

<abs_power>, <abs_power>, <abs_power>, <abs_power>, <abs_power>

[:SENSe] :SEMAsk:REGion:LIST:STOP:ABSolute?

Set an absolute power level for each region stop limit. The list must contain five (5) entries. If there is more than one region, the region closest to the carrier channel comes first in the list.

The fail condition is set by [:SENS]:SEM:REG[n]:LIST:TEST for each region test.

You can turn off (not use) specific regions with [:SENS]:SEM:REG[n]:LIST:STAT.

SENSe Subsystem

The query returns the five (5) sets of the real values currently set to the region stop absolute power limits.

REGion[n] n=1 is the base station test and n=2 is the mobile test. The default is the base station test (1). (cdma2000, W-CDMA mode only)

Factory Preset and *RST:

Mode	Variant	Region A	Region B	Region C	Region D	Region E
cdma2000	BTS	-86.00 dBm	-41.00 dBm	-98.00 dBm	-57.00 dBm	-50.00 dBm
	MS	-41.00 dBm	-67.00 dBm	-79.00 dBm	-71.00 dBm	-50.00 dBm
W-CDMA	n/a	-50.00 dBm	-50.00 dBm	-50.00 dBm	-50.00 dBm	-50.00 dBm
1xEV-DO	n/a	-50.00 dBm	-50.00 dBm	-50.00 dBm	-50.00 dBm	-50.00 dBm

Range: -200.00 dBm to 50.00 dBm

Unit: dBm

Remarks: You must be in the cdma2000, W-CDMA, or 1xEV-DO mode to use this command. Use INSTRument:SElect to set the mode.

Spectrum Emission Mask—Couple Region Stop Absolute Power Limit

**[:SENSe] :SEMAsk:REGion[n] :LIST:STOP:ABSolute:COUple
OFF | ON | 0 | 1 { , OFF | ON | 0 | 1 }**

[:SENSe] :SEMAsk:REGion[n] :LIST:STOP:ABSolute:COUple?

Define whether or not to couple the region stop absolute power limit to the region start absolute power limit for each region.

You can turn off (not use) specific regions with
[:SENS]:SEM:REG[n]:LIST:STAT.

REGion[n] n=1 is the base station test and n=2 is the mobile test. The default is the base station test (1). (cdma2000, W-CDMA mode only)

Factory Preset:

Mode	Region A	Region B	Region C	Region D	Region E
cdma2000	ON	ON	ON	ON	ON
W-CDMA	ON	ON	ON	ON	ON
1xEV-DO	ON	ON	ON	ON	ON

Remarks: You must be in the cdma2000, W-CDMA, or 1xEV-DO mode to use this command. Use INSTRument:SElect to set the mode.

Spectrum Emission Mask—Region Stop Relative Power Limit*cdma2000, W-CDMA mode*

```
[ :SENSe ]:SEMAsk:REGion[n]:LIST:STOP:RCARrier
<rel_power>,<rel_power>,<rel_power>,<rel_power>,<rel_power>
```

```
[ :SENSe ]:SEMAsk:REGion[n]:LIST:STOP:RCARrier?
```

1xEV-DO mode

```
[ :SENSe ]:SEMAsk:REGion:LIST:STOP:RCARrier
<rel_power>,<rel_power>,<rel_power>,<rel_power>,<rel_power>
```

```
[ :SENSe ]:SEMAsk:REGion:LIST:STOP:RCARrier?
```

Set a relative power level for each region stop limit. The list must contain five (5) entries. If there is more than one region, the region closest to the carrier channel comes first in the list.

The fail condition is set by [:SENS]:SEM:REG[n]:LIST[m]:TEST for each region.

You can turn off (not use) specific regions with
[:SENS]:SEM:REG[n]:LIST:STAT.

The query returns the five (5) sets of the real values currently set to the region stop relative power limits.

REGion[n] n=1 is the base station test and n=2 is the mobile test. The default is the base station test (1). (cdma2000, W-CDMA mode only)

Factory Preset:

Mode	Region A	Region B	Region C	Region D	Region E
cdma2000	-30.00 dB	-30.00 dB	-30.00 dB	-30.00 dB	-30.00 dB
W-CDMA	-30.00 dB	-30.00 dB	-30.00 dB	-30.00 dB	-30.00 dB
1xEV-DO	-30.00 dB	-30.00 dB	-30.00 dB	-30.00 dB	-30.00 dB

Range: -150.00 dBm to 50.00 dB

Default Unit: dB

Remarks: You must be in the cdma2000, W-CDMA, or 1xEV-DO mode to use this command. Use INSTRument:SElect to set the mode.

Spectrum Emission Mask—Couple Region Stop Relative Power Limit*cdma2000, W-CDMA mode*

```
[ :SENSe ]:SEMAsk:REGion[n]:LIST:STOP:RCARrier:COUPLE
```

SENSe Subsystem

OFF|ON|0|1,OFF|ON|0|1,OFF|ON|0|1,OFF|ON|0|1,OFF|ON|0|1

[:SENSe] :SEMAsk:REGion[n]:LIST:STOP:RCARrier:COUPlE?

1xEV-DO mode

[:SENSe] :SEMAsk:REGion:LIST:STOP:RCARrier:COUPlE

OFF|ON|0|1,OFF|ON|0|1,OFF|ON|0|1,OFF|ON|0|1,OFF|ON|0|1

[:SENSe] :SEMAsk:REGion:LIST:STOP:RCARrier:COUPlE?

Define whether or not to couple the region stop relative power limit to the region start relative power limit for each region.

You can turn off (not use) specific regions with
[:SENS]:SEM:REG[n]:LIST:STAT.

REGion[n] n=1 is the base station test and n=2 is the mobile test. The default is the base station test (1). (cdma2000, W-CDMA mode only)

Factory Preset:

Mode	Region A	Region B	Region C	Region D	Region E
cdma2000	ON	ON	ON	ON	ON
W-CDMA	ON	ON	ON	ON	ON
1xEV-DO	ON	ON	ON	ON	ON

Remarks: You must be in the cdma2000, W-CDMA, or 1xEV-DO mode to use this command. Use INSTRument:SELEct to set the mode.

Spectrum Emission Mask—Region Limit Test Fail Condition

cdma2000, W-CDMA mode

[:SENSe] :SEMAsk:REGion[n]:LIST:TEST

ABSolute|AND|OR|RELAtive,ABSolute|AND|OR|RELAtive,
ABSolute|AND|OR|RELAtive,ABSolute|AND|OR|RELAtive,
ABSolute|AND|OR|RELAtive

[:SENSe] :SEMAsk:REGion[n]:LIST:TEST?

1xEV-DO mode

[:SENSe] :SEMAsk:REGion:LIST:TEST

ABSolute|AND|OR|RELAtive,ABSolute|AND|OR|RELAtive,
ABSolute|AND|OR|RELAtive,ABSolute|AND|OR|RELAtive,
ABSolute|AND|OR|RELAtive

[:SENSe] :SEMAsk:REGion:LIST:TEST?

Define one of the fail conditions for each region limit test to be done. The absolute

or relative test limit value for each region is set by
[:SENS]:SEM:REG[n]:LIST:ABS or [:SENS]:SEM:REG[n]:LIST:RCAR.

You can turn off (not use) specific regions with
[:SENS]:SEM:REG[n]:LIST[m]:STAT.

REGion[n] n=1 is the base station test and n=2 is the mobile test. The default is the base station test (1). (cdma2000, W-CDMA mode only)

The fail condition that can be set for each region test include:

- AND - Tests the measurement result for a region against both the absolute power limit and the relative power limit. If it fails, then returns a failure for that measurement test.
- ABSolute - Tests the measurement result for a region against the absolute power limit. If it fails, then returns a failure for that measurement test.
- OR - Tests the measurement result for a region against the absolute power limit OR the relative power limit. If either test fails, then returns a failure for that measurement test.
- RELative - Tests the measurement result for a region against the relative power limit. If it fails, then returns a failure for that measurement test.

Factory Preset:

Mode	Region A	Region B	Region C	Region D	Region E
cdma2000	ABS	ABS	ABS	ABS	ABS
W-CDMA	ABS	ABS	ABS	ABS	ABS
1xEV-DO	ABS	ABS	ABS	ABS	ABS

Remarks: You must be in the cdma2000, W-CDMA, or 1xEV-DO mode to use this command. Use INSTRument:SElect to set the mode.

Spectrum Emission Mask—Spectrum Segment

[:SENSe]:SEMask:SEGment OFFSet|REGion

[:SENSe]:SEMask:SEGment?

Set the frequency spectrum measurement segment to either the offset channels with relative frequencies or the regions with absolute frequencies.

Factory Preset: OFFset

Remarks: You must be in the cdma2000, W-CDMA, or 1xEV-DO mode to use this command. Use INSTRument:SElect to set the mode.

SENSe Subsystem

Spectrum Emission Mask—Measurement Mode

[:SENSe] :SEMAsk :SEGMENT :TYPE ACPr | SEMAsk

[:SENSe] :SEMAsk :SEGMENT :TYPE?

Set the measurement mode to either the SEM (spectrum emission mask) mode or the ACP (adjacent channel power) mode.

Factory Preset: SEMAsk

Remarks: You must be in the 1xEV-DO mode to use this command. Use INSTRUMENT:SELEct to set the mode.

History: PSA:
Added in version A.02.00
E4406A:
Added in version A.05.00

Spectrum Emission Mask—Measurement Interval

[:SENSe] :SEMAsk :SWEep :TIME <time> | <no. of chips>

[:SENSe] :SEMAsk :SWEep :TIME?

Specify the time length in μs or number of chips, for the measurement interval that is the data acquisition time for each bin.

Factory Preset: 1 ms
182.3 μs or 224 chips (for 1xEV-DO)

Range: 100 μs to 10 ms
10.0 μs to 10.0 ms or 12.3 to 12300 chips (for 1xEV-DO)

Default Unit: seconds

Remarks: You must be in the cdma2000, W-CDMA, or 1xEV-DO mode to use this command. Use INSTRUMENT:SELEct to set the mode.

Spectrum Emission Mask—Measurement Offset

[:SENSe] :SEMAsk :SWEep :TIME :OFFSet <time> | <no. of chips>

[:SENSe] :SEMAsk :SWEep :TIME :OFFSet?

Specify the time length in μs or no. of chips offset from the measurement trigger.

Factory Preset: 325.5 μs or 400 chips

Range: 0.0 μs to 1667.0 μs or 0 to 2048 chips

Default Unit: seconds

Remarks: You must be in the 1xEV-DO mode to use this command. Use

INSTRument:SElect to set the mode.

History: PSA:
 Added in version A.02.00
 E4406A:
 Added in version A.05.00

Spectrum Emission Mask—Trigger Source

[:SENSe] : SEMask : TRIGger : SOURCE
 EXTErnal [1] | EXTErnal2 | FRAMe | IMMEDIATE | LINE

[:SENSe] : SEMask : TRIGger : SOURCE?

Select one of the trigger sources used to control the data acquisitions.

EXTErnal 1 – front panel external trigger input

EXTErnal 2 – rear panel external trigger input

FRAMe – internal frame trigger

IMMEDIATE – the next data acquisition is immediately taken, capturing the signal asynchronously (also called free run).

LINE – power line

Factory Preset: IMMEDIATE

Remarks: You must be in the cdma2000, W-CDMA, or 1xEV-DO mode to use this command. Use INSTRument:SElect to set the mode.

Spectrum Emission Mask—Power Reference

[:SENSe] : SEMask : TYPE PSDRef|TPRef

[:SENSe] : SEMask : TYPE?

Set the power measurement reference type. This allows you to make absolute and relative power measurements of either total power or the power normalized to the measurement bandwidth.

PSDRef - the power spectral density is used as the power reference

TPRef - the total power is used as the power reference

Factory Preset: TPRef

Remarks: You must be in the cdma2000, W-CDMA, 1xEV-DO mode to use this command. Use INSTRument:SElect to set the mode.

Spectrum (Frequency-Domain) Measurement

Commands for querying the spectrum measurement results and for setting to the default values are found in the “MEASure Group of Commands” on page 193. The equivalent front panel keys for the parameters described in the following commands, are found under the Meas Setup key, after the Spectrum (Freq Domain) measurement has been selected from the MEASURE key menu.

Spectrum—Data Acquisition Packing

```
[ :SENSe ] :SPECTrum:ACQuisition:PACKing  
AUTO | LONG | MEDium | SHORT
```

```
[ :SENSe ] :SPECTrum:ACQuisition:PACKing?
```

Select the amount of data acquisition packing. This is an advanced control that normally does not need to be changed.

Factory Preset: AUTO

Remarks: To use this command for E4406A, the appropriate mode should be selected with INSTRument:SElect.

For PSA you must be in the Basic, cdmaOne, cdma2000, 1xEV-DO, W-CDMA, GSM, EDGE, NADC, or PDC mode to use this command. Use INSTRument:SElect to set the mode.

Spectrum—ADC Dither

```
[ :SENSe ] :SPECTrum:ADC:DITHer [ :STATe ] AUTO | ON | OFF | 2 | 1 | 0
```

```
[ :SENSe ] :SPECTrum:ADC:DITHer [ :STATe ] ?
```

Turn the ADC dither on or off. This is an advanced control that normally does not need to be changed.

Factory Preset: AUTO

Remarks: To use this command for E4406A, the appropriate mode should be selected with INSTRument:SElect.

For PSA you must be in the Basic, cdmaOne, cdma2000, 1xEV-DO, W-CDMA, GSM, EDGE, NADC, or PDC mode to use this command. Use INSTRument:SElect to set the mode.

Spectrum—ADC Range

E4406A

```
[ :SENSe ] :SPECTrum:ADC:RANGe  
AUTO | APEak | APLock | M6 | P0 | P6 | P12 | P18 | P24
```

PSA

```
[ :SENSe ] :SPECTrum:ADC:RANGe
```

AUTO | APEak | APLOCK | NONE | P0 | P6 | P12 | P18

[:SENSe] :SPECTrum:ADC:RANGe?

Select the range for the gain-ranging that is done in front of the ADC. This is an advanced control that normally does not need to be changed. Auto peak ranging is the default for this measurement. If you are measuring a CW signal please see the description below.

- **AUTO** - automatic range

For FFT spectrums - auto ranging should not be used. An exception to this would be if you know that your signal is “bursty”. Then you might use auto to maximize the time domain dynamic range as long as you are not very interested in the FFT data.
- **Auto Peak (APEak)** - automatically peak the range

For CW signals, the default of auto-peak ranging can be used, but a better FFT measurement of the signal can be made by selecting one of the manual ranges that are available: M6, P0 - P24.
Auto peaking can cause the ADC range gain to move monotonically down during the data capture. This movement should have negligible effect on the FFT spectrum, but selecting a manual range removes this possibility. Note that if the CW signal being measured is close to the auto-ranging threshold, the noise floor may shift as much as 6 dB from sweep to sweep.
- **Auto Peak Lock (APLOCK)** - automatically peak lock the range

For CW signals, auto-peak lock ranging may be used. It will find the best ADC measurement range for this particular signal and will not move the range as auto-peak can. Note that if the CW signal being measured is close to the auto-ranging threshold, the noise floor may shift as much as 6 dB from sweep to sweep.
For “bursty” signals, auto-peak lock ranging should not be used. The measurement will fail to operate, since the wrong (locked) ADC range will be chosen often and overloads will occur in the ADC.
- **NONE** - (PSA) turns off any auto-ranging without making any changes to the current setting.
- **M6** - (E4406A) manually selects an ADC range that subtracts 6 dB of fixed gain across the range. Manual ranging is best for CW signals.
- **P0 to P18** - (PSA) manually selects ADC ranges that add 0 to 18 dB of fixed gain across the range. Manual ranging is best for CW signals.
- **P0 to 24** - (E4406A) manually selects ADC ranges that add 0 to 24 dB of fixed gain across the range. Manual ranging is best for CW signals.

Factory Preset: APEak

Remarks: To use this command for E4406A, the appropriate mode should be selected with INSTRument:SElect.

For PSA you must be in the Basic, cdmaOne, cdma2000,

SENSE Subsystem

1xEV-DO, W-CDMA, GSM, EDGE, NADC, or PDC mode to use this command. Use INSTRUMENT:SELEct to set the mode.

Spectrum—Average Clear

[:SENSE] :SPECTrum:AVERAge:CLEAr

The average data is cleared and the average counter is reset.

Remarks: To use this command for E4406A, the appropriate mode should be selected with INSTRUMENT:SELEct.

For PSA you must be in the Basic, cdmaOne, cdma2000, 1xEV-DO, W-CDMA, GSM, EDGE, NADC, or PDC mode to use this command. Use INSTRUMENT:SELEct to set the mode.

Spectrum—Number of Averages

[:SENSE] :SPECTrum:AVERAge:COUNT <integer>

[:SENSE] :SPECTrum:AVERAge:COUNT?

Set the number of ‘sweeps’ that will be averaged. After the specified number of ‘sweeps’ (average counts), the averaging mode (terminal control) setting determines the averaging action.

Factory Preset: 25

Range: 1 to 10,000

Remarks: To use this command for E4406A, the appropriate mode should be selected with INSTRUMENT:SELEct.

For PSA you must be in the Basic, cdmaOne, cdma2000, 1xEV-DO, W-CDMA, GSM, EDGE, NADC, or PDC mode to use this command. Use INSTRUMENT:SELEct to set the mode.

Spectrum—Averaging State

[:SENSE] :SPECTrum:AVERAge[:STATe] OFF|ON|0|1

[:SENSE] :SPECTrum:AVERAge[:STATe]?

Turn averaging on or off.

Factory Preset: ON

Remarks: To use this command for E4406A, the appropriate mode should be selected with INSTRUMENT:SELEct.

For PSA you must be in the Basic, cdmaOne, cdma2000, 1xEV-DO, W-CDMA, GSM, EDGE, NADC, or PDC mode to

use this command. Use INSTRument:SElect to set the mode.

Spectrum—Averaging Mode

```
[ :SENSe ] :SPECTrum:AVERAge:TCONtrol EXPonential | REPeat
```

```
[ :SENSe ] :SPECTrum:AVERAge:TCONtrol?
```

Select the type of termination control used for the averaging function. This determines the averaging action after the specified number of 'sweeps' (average count) is reached.

EXPonential - Each successive data acquisition after the average count is reached, is exponentially weighted and combined with the existing average.

REPeat - After reaching the average count, the averaging is reset and a new average is started.

Factory Preset: EXPonential

Remarks: To use this command for E4406A, the appropriate mode should be selected with INSTRument:SElect.

For PSA you must be in the Basic, cdmaOne, cdma2000, 1xEV-DO, W-CDMA, GSM, EDGE, NADC, or PDC mode to use this command. Use INSTRument:SElect to set the mode.

Spectrum—Averaging Type

```
[ :SENSe ] :SPECTrum:AVERAge:TYPE
```

```
LOG | MAXimum | MINimum | RMS | SCALar
```

```
[ :SENSe ] :SPECTrum:AVERAge:TYPE?
```

Select the type of averaging.

LOG – The log of the power is averaged. (This is also known as video averaging.)

MAXimum – The maximum values are retained.

MINimum – The minimum values are retained.

RMS – The power is averaged, providing the rms of the voltage.

SCALar – The voltage is averaged.

Factory Preset: LOG

Remarks: To use this command for E4406A, the appropriate mode should be selected with INSTRument:SElect.

For PSA you must be in the Basic, cdmaOne, cdma2000, 1xEV-DO, W-CDMA, GSM, EDGE, NADC, or PDC mode to use this command. Use INSTRument:SElect to set the mode.

SENSe Subsystem

Spectrum— Select Pre-FFT Bandwidth

```
[ :SENSe ] :SPECTrum :BANDwidth | BWIDth :IF :AUTO OFF | ON | 0 | 1
```

```
[ :SENSe ] :SPECTrum :BANDwidth | BWIDth :IF :AUTO?
```

Select auto or manual control of the pre-FFT BW.

Factory Preset: AUTO, 1.55 MHz

Remarks: To use this command for E4406A, the appropriate mode should be selected with INSTRUMENT:SElect.

For PSA you must be in the Basic, cdmaOne, cdma2000, 1xEV-DO, W-CDMA, GSM, EDGE, NADC, or PDC mode to use this command. Use INSTRUMENT:SElect to set the mode.

Front Panel

Access: Measure, Spectrum, Meas Setup, More, Advanced, Pre-FFT BW.

Spectrum — IF Flatness Corrections

```
[ :SENSe ] :SPECTrum :BANDwidth | BWIDth :IF :FLATness OFF | ON | 0 | 1
```

```
[ :SENSe ] :SPECTrum :BANDwidth | BWIDth :IF :FLATness?
```

Turns IF flatness corrections on and off.

Factory Preset: ON

Remarks: To use this command for E4406A, the appropriate mode should be selected with INSTRUMENT:SElect.

For PSA you must be in the Basic, cdmaOne, cdma2000, 1xEV-DO, W-CDMA, GSM, EDGE, NADC, or PDC mode to use this command. Use INSTRUMENT:SElect to set the mode.

Front Panel

Access: Measure, Spectrum, Meas Setup, More, Advanced, Pre-FFT BW

Spectrum—Pre-ADC Bandpass Filter

```
[ :SENSe ] :SPECTrum :BANDwidth | BWIDth :PADC OFF | ON | 0 | 1
```

```
[ :SENSe ] :SPECTrum :BANDwidth | BWIDth :PADC?
```

Turn the pre-ADC bandpass filter on or off. This is an advanced control that normally does not need to be changed.

Remarks: To use this command for E4406A, the appropriate mode should be selected with INSTRUMENT:SElect.

For PSA you must be in the Basic, cdmaOne, cdma2000,

1xEV-DO, W-CDMA, GSM, EDGE, NADC, or PDC mode to use this command. Use INSTRUMENT:SElect to set the mode.

Spectrum—Pre-FFT BW

```
[ :SENSE ] :SPECTrum: BANDwidth | BWIDth: PFFT [ :SIZE ] <freq>
```

```
[ :SENSE ] :SPECTrum: BANDwidth | BWIDth: PFFT [ :SIZE ] ?
```

Set the pre-FFT bandwidth. This is an advanced control that normally does not need to be changed.

Frequency span, resolution bandwidth, and the pre-FFT bandwidth settings are normally coupled. If you are not auto-coupled, there can be combinations of these settings that are not valid.

Factory Preset: 1.55 MHz

1.25 MHz for cdmaOne

155.0 kHz, for iDEN mode (E4406A)

Range: 1 Hz to 10.0 MHz

Remarks: To use this command for E4406A, the appropriate mode should be selected with INSTRUMENT:SElect.

For PSA you must be in the Basic, cdmaOne, cdma2000, 1xEV-DO, W-CDMA, GSM, EDGE, NADC, or PDC mode to use this command. Use INSTRUMENT:SElect to set the mode.

Spectrum—Pre-FFT BW Filter Type

```
[ :SENSE ] :SPECTrum: BANDwidth | BWIDth: PFFT: TYPE FLAT | GAUSSian
```

```
[ :SENSE ] :SPECTrum: BANDwidth | BWIDth: PFFT: TYPE ?
```

Select the type of pre-FFT filter that is used. This is an advanced control that normally does not need to be changed.

Flat top (FLAT)- a filter with a flat amplitude response, which provides the best amplitude accuracy.

GAUSSian - a filter with Gaussian characteristics, which provides the best pulse response.

Factory Preset: FLAT

Remarks: To use this command for E4406A, the appropriate mode should be selected with INSTRUMENT:SElect.

For PSA you must be in the Basic, cdmaOne, cdma2000, 1xEV-DO, W-CDMA, GSM, EDGE, NADC, or PDC mode to use this command. Use INSTRUMENT:SElect to set the mode.

SENSe Subsystem

Spectrum—Resolution BW

```
[ :SENSe ] :SPECTrum: BANDwidth | BWIDth [ :RESolution ] <freq>
```

```
[ :SENSe ] :SPECTrum: BANDwidth | BWIDth [ :RESolution ] ?
```

Set the resolution bandwidth for the FFT. This is the bandwidth used for resolving the FFT measurement. It is not the pre-FFT bandwidth. This value is ignored if the function is auto-coupled.

Frequency span, resolution bandwidth, and the pre-FFT bandwidth settings are normally coupled. If you are not auto-coupled, there can be combinations of these settings that are not valid.

Factory Preset: 20.0 kHz

250.0 Hz, for iDEN mode (E4406A)

Range: 0.10 Hz to 3.0 MHz

Remarks: To use this command for E4406A, the appropriate mode should be selected with INSTRument:SElect.

For PSA you must be in the Basic, cdmaOne, cdma2000, 1xEV-DO, W-CDMA, GSM, EDGE, NADC, or PDC mode to use this command. Use INSTRument:SElect to set the mode.

Spectrum—Resolution BW Auto

```
[ :SENSe ] :SPECTrum: BANDwidth | BWIDth [ :RESolution ] :AUTO  
OFF | ON | 0 | 1
```

```
[ :SENSe ] :SPECTrum: BANDwidth | BWIDth [ :RESolution ] :AUTO?
```

Select auto or manual control of the resolution BW. The automatic mode couples the resolution bandwidth setting to the frequency span.

Factory Preset: ON

OFF, for iDEN mode (E4406A)

Remarks: To use this command for E4406A, the appropriate mode should be selected with INSTRument:SElect.

For PSA you must be in the Basic, cdmaOne, cdma2000, W-CDMA, GSM, EDGE, NADC, or PDC mode to use this command. Use INSTRument:SElect to set the mode.

Decimation of Spectrum Display

```
[ :SENSe ] :SPECTrum: DECimate [ :FACTor ] <integer>
```

[:SENSe] :SPECTrum:DECimate [:FACTor] ?

Sets the amount of data decimation done by the hardware and/or the software. Decimation by *n* keeps every *n*th sample, throwing away each of the remaining samples in the group of *n*. For example, decimation by 3 keeps every third sample, throwing away the two in between. Similarly, decimation by 5 keeps every fifth sample, throwing away the four in between.

Using zero (0) decimation selects the automatic mode. The measurement will then automatically choose decimation by “1” or “2” as is appropriate for the bandwidth being used.

This is an advanced control that normally does not need to be changed.

Factory Preset: 0

Range: 0 to 1,000, where 0 sets the function to automatic

Remarks: To use this command for E4406A, the appropriate mode should be selected with INSTRument:SElect.

For PSA you must be in the Basic, cdmaOne, cdma2000, 1xEV-DO, W-CDMA, GSM, EDGE, NADC, or PDC mode to use this command. Use INSTRument:SElect to set the mode.

History: E4406A:
Version A.02.00 or later

Spectrum—FFT Length**[:SENSe] :SPECTrum:FFT:LENGth <integer>****[:SENSe] :SPECTrum:FFT:LENGth?**

Set the FFT length. This value is only used if length control is set to manual. The value must be greater than or equal to the window length value. Any amount greater than the window length is implemented by zero-padding. This is an advanced control that normally does not need to be changed.

Factory Preset: 706

Range: min, depends on the current setting of the spectrum window length
max, 1,048,576

Remarks: To use this command for E4406A, the appropriate mode should be selected with INSTRument:SElect.

For PSA you must be in the Basic, cdmaOne, cdma2000, 1xEV-DO, W-CDMA, GSM, EDGE, NADC, or PDC mode to use this command. Use INSTRument:SElect to set the mode.

History: E4406A:
Short form changed from LENGth to LENGth, A.03.00

SENSe Subsystem

Spectrum—FFT Length Auto

[:SENSe] :SPECTrum:FFT:LENGth:AUTO OFF | ON | 0 | 1

[:SENSe] :SPECTrum:FFT:LENGth:AUTO?

Select auto or manual control of the FFT and window lengths.

This is an advanced control that normally does not need to be changed.

On - the window lengths are coupled to resolution bandwidth, window type (FFT), pre-FFT bandwidth (sample rate) and SENSe:SPECTrum:FFT:RBWPoints.

Off - lets you set SENSe:SPECTrum:FFT:LENGth and SENSe:SPECTrum:FFT:WINDow:LENGth.

Factory Preset: ON

Remarks: To use this command for E4406A, the appropriate mode should be selected with INSTRument:SElect.

For PSA you must be in the Basic, cdmaOne, cdma2000, 1xEV-DO, W-CDMA, GSM, EDGE, NADC, or PDC mode to use this command. Use INSTRument:SElect to set the mode.

History: E4406A:
Short form changed from LENGth to LENGh, A.03.00

Spectrum—FFT Minimum Points in Resolution BW

[:SENSe] :SPECTrum:FFT:RBWPoints <real>

[:SENSe] :SPECTrum:FFT:RBWPoints?

Set the minimum number of data points that will be used inside the resolution bandwidth. The value is ignored if length control is set to manual. This is an advanced control that normally does not need to be changed.

Factory Preset: 1.30

Range: 0.1 to 100

Remarks: To use this command for E4406A, the appropriate mode should be selected with INSTRument:SElect.

For PSA you must be in the Basic, cdmaOne, cdma2000, 1xEV-DO, W-CDMA, GSM, EDGE, NADC, or PDC mode to use this command. Use INSTRument:SElect to set the mode.

Spectrum—Window Delay

```
[ :SENSe ] :SPECTrum:FFT:WINDow:DELAy <real>
```

```
[ :SENSe ] :SPECTrum:FFT:WINDow:DELAy?
```

Set the FFT window delay to move the FFT window from its nominal position of being centered within the time capture. This function is not available from the front panel. It is an advanced control that normally does not need to be changed.

Factory Preset: 0

Range: -10.0 to +10.0s

Default Unit: seconds

Remarks: To use this command for E4406A, the appropriate mode should be selected with INSTRument:SElect.

For PSA you must be in the Basic, cdmaOne, cdma2000, 1xEV-DO, W-CDMA, GSM, EDGE, NADC, or PDC mode to use this command. Use INSTRument:SElect to set the mode.

Spectrum—Window Length

```
[ :SENSe ] :SPECTrum:FFT:WINDow:LENGth <integer>
```

```
[ :SENSe ] :SPECTrum:FFT:WINDow:LENGth?
```

Set the FFT window length. This value is only used if length control is set to manual. This is an advanced control that normally does not need to be changed.

Factory Preset: 706

Range: 8 to 1,048,576

Remarks: To use this command for E4406A, the appropriate mode should be selected with INSTRument:SElect.

For PSA you must be in the Basic, cdmaOne, cdma2000, 1xEV-DO, W-CDMA, GSM, EDGE, NADC, or PDC mode to use this command. Use INSTRument:SElect to set the mode.

History: E4406A:
Short form changed from LENGth to LENGth, A.03.00

Spectrum—FFT Window

```
[ :SENSe ] :SPECTrum:FFT:WINDow[ :TYPE ]
```

```
BH4Tap | BLACkman | FLATtop | GAUSSian | HAMming | HANNing | KB70 | KB90 |  
KB110 | UNIFORM
```

```
[ :SENSe ] :SPECTrum:FFT:WINDow[ :TYPE ]?
```

Select the FFT window type.

SENSe Subsystem

BH4Tap - Blackman Harris with 4 taps

BLACkman - Blackman

FLATtop - flat top, the default (for high amplitude accuracy)

GAUSSian - Gaussian with alpha of 3.5

HAMMing - Hamming

HANNing - Hanning

KB70, 90, and 110 - Kaiser Bessel with sidelobes at -70, -90, or -110 dBc

UNIFORM - no window is used. (This is the unity response.)

Factory Preset: FLATtop

Remarks: This selection affects the acquisition point quantity and the FFT size, based on the resolution bandwidth selected.

To use this command for E4406A, the appropriate mode should be selected with INSTRUMENT:SElect.

For PSA you must be in the Basic, cdmaOne, cdma2000, 1xEV-DO, W-CDMA, GSM, EDGE, NADC, or PDC mode to use this command. Use INSTRUMENT:SElect to set the mode.

Spectrum—Frequency Span

[:SENSe] :SPECTrum:FREQuency:SPAN <freq>

[:SENSe] :SPECTrum:FREQuency:SPAN?

Set the frequency span to be measured.

Factory Preset: 1.0 MHz

100.0 kHz for iDEN mode (E4406A)

Range: 10 Hz to 10.0 MHz (15 MHz when Service mode is selected)

Default Unit: Hz

Remarks: The actual measured span will generally be slightly wider due to the finite resolution of the FFT.

To use this command for E4406A, the appropriate mode should be selected with INSTRUMENT:SElect.

For PSA you must be in the Basic, cdmaOne, cdma2000, 1xEV-DO, W-CDMA, GSM, EDGE, NADC, or PDC mode to use this command. Use INSTRUMENT:SElect to set the mode.

Spectrum—Sweep (Acquisition) Time

```
[ :SENSe ] :SPECTrum:SWEep:TIME[ :VALue ] <time>
```

```
[ :SENSe ] :SPECTrum:SWEep:TIME?
```

Set the sweep (measurement acquisition) time. It is used to specify the length of the time capture record. If the value you specify is less than the capture time required for the specified span and resolution bandwidth, the value is ignored. The value is set at its auto value when auto is selected. This is an advanced control that normally does not need to be changed.

Factory Preset: 188.0 μ s

15.059 ms, for iDEN mode (E4406A)

Range: 100 ns to 10 s

Default Unit: seconds

Remarks: To use this command for E4406A, the appropriate mode should be selected with INSTRument:SElect.

For PSA you must be in the Basic, cdmaOne, cdma2000, 1xEV-DO, W-CDMA, GSM, EDGE, NADC, or PDC mode to use this command. Use INSTRument:SElect to set the mode.

Spectrum—Sweep (Acquisition) Time Auto

```
[ :SENSe ] :SPECTrum:SWEep:TIME:AUTO OFF | ON | 0 | 1
```

```
[ :SENSe ] :SPECTrum:SWEep:TIME:AUTO
```

Select auto or manual control of the sweep (acquisition) time. This is an advanced control that normally does not need to be changed.

AUTO - couples the Sweep Time to the Frequency Span and Resolution BW

Manual - the Sweep Time is uncoupled from the Frequency Span and Resolution BW.

Factory Preset: AUTO

Remarks: To use this command for E4406A, the appropriate mode should be selected with INSTRument:SElect.

For PSA you must be in the Basic, cdmaOne, cdma2000, 1xEV-DO, W-CDMA, GSM, EDGE, NADC, or PDC mode to use this command. Use INSTRument:SElect to set the mode.

Spectrum—Trigger Source

```
[ :SENSe ] :SPECTrum:TRIGger:SOURce
```

```
EXTernal[1] | EXTernal2 | FRAME | IF | LINE | IMMEDIATE | RFBURSt
```

SENSE Subsystem

[:SENSE] :SPECTrum:TRIGger:SOURce?

Select the trigger source used to control the data acquisitions.

EXTernal1 - front panel external trigger input

EXTernal2 - rear panel external trigger input

FRAMe - internal frame timer from front panel input

IF - internal IF envelope (video) trigger

LINE - internal line trigger

IMMEDIATE - the next data acquisition is immediately taken (also called free run)

RFBurst - wideband RF burst envelope trigger that has automatic level control for periodic burst signals

Factory Preset: IMMEDIATE (free run)

RFBurst, for GSM, iDEN mode

Remarks: To use this command for E4406A, the appropriate mode should be selected with INSTRUMENT:SELECT.

For PSA you must be in the Basic, cdmaOne, cdma2000, 1xEV-DO, W-CDMA, GSM, EDGE, NADC, or PDC mode to use this command. Use INSTRUMENT:SELECT to set the mode.

Synchronization Commands

Sync Type

[:SENSe] :SYNC ESECond | EXTernal[1] | EXTernal2 | NONE | PSEquence

[:SENSe] :SYNC?

Select the demodulation sync type for the waveform accuracy (Rho) and code domain power measurements.

Even Second (ESECond) - Even second clock

EXTernal 1 - front panel external trigger input

EXTernal 2 - rear panel external trigger input

NONE - no demod sync (uses free run trigger)

Pilot Sequence (PSEquence) - pilot sequence sync (uses frame trigger)

Factory Preset: ESECond

Remarks: Global to the current mode.

You must be in the cdmaOne mode to use this command. Use INSTRument:SELEct to set the mode.

Front Panel

Access: **Mode Setup, Trigger, Sync Type**

History: E4406A:
Front/Rear panel swapped EXT2/EXT1, A.03.00

Sync Alignment

[:SENSe] :SYNC:ALIGNment GSM | HBIT

[:SENSe] :SYNC:ALIGNment?

Select the sync alignment to be either to the GSM standard or the standard offset by 1/2 bit.

GSM - burst alignment as defined in the GSM standard

HBIT - burst alignment is advanced by 1/2 bit, which corresponds to an earlier interpretation of the GSM standard

Factory Preset: HBIT

Remarks: Global to the current mode.

You must be in the GSM, EDGE mode to use this command. Use INSTRument:SELEct to set the mode.

Front Panel

Access: **Mode Setup, Demod, Burst Align**

SENSe Subsystem

Burst Sync Delay

[:SENSe] : SYNC : BURSt : DELay <time>

[:SENSe] : SYNC : BURSt : DELay ?

Set the delay for the burst measurement position from the reference position that is determined by sync word or the burst rising/falling edges.

Factory Preset: 0 sec

Range: -500 ms to 500 ms

Default Unit: seconds

Remarks: You must be in the iDEN (E4406A), NADC or PDC mode to use this command. Use INSTRument:SELEct to set the mode.

Sync Burst RF Amplitude Delay

[:SENSe] : SYNC : BURSt : RFAMplitude : DELay <time>

[:SENSe] : SYNC : BURSt : RFAMplitude : DELay ?

Set the delay for the RF amplitude sync.

Factory Preset: 0 s

Range: -100 ms to 100 ms

Default Unit: seconds

Remarks: Global to the current mode.

You must be in the GSM, EDGE mode to use this command.
Use INSTRument:SELEct to set the mode.

Front Panel

Access: **Mode Setup, Trigger, RF Sync Delay**

Burst Search Threshold

[:SENSe] : SYNC : BURSt : STHreshold <rel_power>

[:SENSe] : SYNC : BURSt : STHreshold ?

Set the relative power threshold, which is used to determine the timeslots that will be included in the search for GSM bursts. For measurements that have burst sync set to training sequence, these bursts will be the only ones that will be searched for valid TSC's (training sequence codes). The threshold power is relative to the peak power of the highest power timeslot. This is useful when measuring a BTS with different power levels in different timeslots, and you want to exclude bursts with lower power levels.

Factory Preset: -10 dB
 Range: -200 to -0.01 dB
 Default Unit: dB
 Remarks: You must be in the GSM, EDGE mode to use this command.
 Use INSTRument:SElect to set the mode.
 Front Panel
 Access: **Mode Setup, Trigger, Slot Threshold**

Burst Search Threshold

`[:SENSe] : SYNC : STHReshold <rel_power>`

`[:SENSe] : SYNC : STHReshold?`

Set the power threshold, relative to the peak power, that is used to determine the burst rising edge and falling edge.

Factory Preset: -30 dB
 Range: -200 to -0.01 dB
 Default Unit: dB
 Remarks: You must be in the iDEN (E4406A), NADC or PDC mode to use this command. Use INSTRument:SElect to set the mode.
 Front Panel
 Access: **Mode Setup, Trigger, Burst Search Threshold**

Terminal Code Domain Measurement

Commands for querying the terminal code domain measurement results and for setting to the default values are found in the “MEASure Group of Commands” on page 193.

Terminal Code Domain Measurement–Active Code Channel

```
[ :SENSE ] :TCDPower :ACode AUTO | COMBination | PREDefined
```

```
[ :SENSE ] :TCDPower :ACode?
```

Set the reverse link active code detection mode.

- AUTO - It is automatically detected (by internal algorithm) whether or not channel is active.
- COMBination - Channel specified by predefined (Pilot/DRC/ACK/Data) whether or not it is active automatically (by internal algorithm).
- PREDefined - It is decided by predefined information (Pilot/DRC/ACK/Data) whether or not channel is active.

Factory Preset: AUTO

Remarks: You must be in the 1xEV-DO mode to use this command. Use INSTRument:SElect to set the mode.

Terminal Code Domain Measurement–ACK Channel Definition

```
[ :SENSE ] :TCDPower :ACode :ACK OFF | ON | 0 | 1
```

```
[ :SENSE ] :TCDPower :ACode :ACK?
```

Set the reverse link ACK channel to active (On) or inactive (Off).

- On - Reverse link ACK is set to active.
- Off - Reverse link ACK is set to inactive.

Factory Preset: On

Remarks: You must be in the 1xEV-DO mode to use this command. Use INSTRument:SElect to set the mode.

Terminal Code Domain Measurement–Data Channel Definition

```
[ :SENSE ] :TCDPower :ACode :DATA OFF | ON | 0 | 1
```

```
[ :SENSE ] :TCDPower :ACode :DATA?
```

Set the reverse link data channel to active (On) or inactive (Off).

- On - Reverse link data is set to active.

- Off - Reverse link data is set to inactive.

Factory Preset: On

Remarks: You must be in the 1xEV-DO mode to use this command. Use INSTRUMENT:SElect to set the mode.

Terminal Code Domain Measurement–DRC Channel Definition

[:SENSE] : TCDPower : ACode : DRC OFF | ON | 0 | 1

[:SENSE] : TCDPower : ACode : DRC?

Set the reverse link DRC channel to active (On) or inactive (Off).

- On - Reverse link DRC is set to active.
- Off - Reverse link DRC is set to inactive.

Factory Preset: On

Remarks: You must be in the 1xEV-DO mode to use this command. Use INSTRUMENT:SElect to set the mode.

Terminal Code Domain Measurement–Pilot Channel Definition

[:SENSE] : TCDPower : ACode : PIlot OFF | ON | 0 | 1

[:SENSE] : TCDPower : ACode : PIlot?

Set the reverse link pilot channel to active (On) or inactive (Off).

- On - Reverse link pilot is set to active.
- Off - Reverse link pilot is set to inactive.

Factory Preset: On

Remarks: You must be in the 1xEV-DO mode to use this command. Use INSTRUMENT:SElect to set the mode.

Terminal Code Domain Measurement–ADC Range

[:SENSE] : TCDPower : ADC : RANGE

AUTO | APEak | APLock | NONE | P0 | P6 | P12 | P18 | P24 | M6

[:SENSE] : TCDPower : ADC : RANGE?

Select a ranging function for the ADC gain control. This is an advanced control that normally does not need to be changed. If you are measuring a CW signal, see the following description.

- AUTO - This is automatic ranging. For FFT spectrums the auto ranging should not be used. An exception to this is if you know that your signal is “bursty,”

SENSe Subsystem

then you can use auto to maximize the time domain dynamic range as long as you are not very interested in the FFT data.

- **APEak (Auto Peak)** - This is automatic ranging to the peak signal level. For CW signals the default of auto-peak ranging can be used. However, a better FFT measurement of the signal can be made by selecting one of the manual ranges available by specifying NONE, or P0 through P18. Auto peaking can cause the ADC gain to monotonically track the ranges down during the data capture. This tracking effect should be negligible for the FFT spectrum, but selecting a manual range solves this possibility. If the CW signal being measured is close to the auto-ranging threshold, the noise floor may shift as much as 6 dB every sweep.
- **APLock (Auto Peak Lock)** - This is automatic ranging locked to the peak signal level. For CW signals, auto-peak lock ranging may be used. It will find the ADC gain most appropriate for this particular signal and will not track the ranges as auto peak can. If the CW signal being measured is close to the auto-ranging threshold, the noise floor may shift as much as 6 dB every sweep. For “bursty” signals, auto peak lock ranging should not be used. Since the ADC range can often be locked to the wrong one (resulting in overloading the ADC) the measurement will fail.
- **NONE** - This turns off any auto-ranging without making any changes to the current setting. This is not applicable for use with an Agilent VSA having a 12-bit ADC Board).
- **P0 through P18, P24, M6** - Manually selects one of the ADC ranges that add 0 dB (P0) to 18 dB (P18) and –6 dB (M6), 24 dB (P24) to the fixed gain across the range. Manual ranging is best for CW signals. M6 and P24 are applicable only for Agilent VSA analyzers having a 14-bit ADC board.

Factory Preset: NONE for Agilent PSA analyzers, including Agilent VSA analyzers with the 14-bit ADC board.

M6 for Agilent VSA analyzers with the 12-bit ADC board.

Remarks: You must be in the 1xEV-DO mode to use this command. Use INSTRUMENT:SElect to set the mode.

Terminal Code Domain Measurement–Data Capture Time

```
[ :SENSe ] :TCDPower :CAPTURE :TIME <integer>
```

```
[ :SENSe ] :TCDPower :CAPTURE :TIME?
```

Set the length of data capture in slots that will be used in the acquisition (1 slot = 1.667 ms).

Factory Preset: 5

Range: 2 to 32 slots (3.333 ms to 53.333 ms)

Remarks: You must be in the 1xEV-DO mode to use this command. Use

INSTRument:SElect to set the mode.

Terminal Code Domain Measurement–Chip Rate

[:SENSe] : TCDPower : CRATe <freq>

[:SENSe] : TCDPower : CRATe?

Set the chip rate.

Factory Preset: 1.2288 MHz

Range: 1.10592 MHz to 1.35168 MHz (default $\pm 10\%$)

Resolution: 1 Hz

Step: 1 kHz

Remarks: You must be in the 1xEV-DO mode to use this command. Use INSTRument:SElect to set the mode.

Terminal Code Domain Measurement Trigger Source

[:SENSe] : TCDPower : TRIGger : SOURce

EXTernal[1] | EXTernal2 | IMMEDIATE | RFBurst | IF | FRAME

[:SENSe] : TCDPower : TRIGger : SOURce?

Set the trigger source used to control the data acquisitions.

- EXTernal[1] - Front panel external trigger input
- EXTernal2 - Rear panel external trigger input
- IMMEDIATE - The next data acquisition is immediately taken, capturing the signal asynchronously (also called Free Run).
- RFBurst - Internal wideband RF burst envelope trigger that has automatic level control for periodic burst signals.
- IF - Internal IF envelope trigger.
- FRAME - Internal frame trigger.

Factory Preset: IMMEDIATE

Remarks: You must be in the 1xEV-DO mode to use this command. Use INSTRument:SElect to set the mode.

Terminal Code Domain Measurement–Spectrum Normal/Invert

[:SENSe] : TCDPower : SPECTrum NORMAl | INVert

[:SENSe] : TCDPower : SPECTrum?

SENSe Subsystem

Select normal or inverted spectrum for the demodulation-related measurements.

NORMal - normal

INVert - The upper and lower spectrum are swapped

Factory Preset: NORMal

Range: 1.10592 MHz to 1.35168 MHz (default $\pm 10\%$)

Remarks: You must be in the 1xEV-DO mode to use this command. Use INSTRument:SElect to set the mode.

Terminal Code Domain Measurement–I Long Code Mask

[:SENSe] :TCDPower:SYNC:ILCMask <long_integer>

[:SENSe] :TCDPower:SYNC:ILCMask?

Set the I long code mask for CDP.

Factory Preset: 0x0

Range: 0x0 to 0x3f ffff ffff (42 bits))

Remarks: You must be in the 1xEV-DO mode to use this command. Use INSTRument:SElect to set the mode.

Terminal Code Domain Measurement–Q Long Code Mask

[:SENSe] :TCDPower:SYNC:QLCMask <long_integer>

[:SENSe] :TCDPower:SYNC:QLCMask?

Set the Qlong code mask for CDP.

Factory Preset: 0x0

Range: 0x0 to 0x3f ffff ffff (42 bits))

Remarks: You must be in the 1xEV-DO mode to use this command. Use INSTRument:SElect to set the mode.

Transmit Band Spurs Measurement

Commands for querying the transmit band spurs measurement results and for setting to the default values are found in the “MEASure Group of Commands” on [page 193](#). The equivalent front panel keys for the parameters described in the following commands, are found under the **Meas Setup** key, after the **GMSK TxBand Spur** measurement has been selected from the **MEASURE** key menu.

Transmit Band Spurs—Average Count

[:SENSe] : TSPur : AVERAge : COUNT <integer>

[:SENSe] : TSPur : AVERAge : COUNT ?

Set the number of data acquisitions that will be averaged. After the specified number of average counts, the averaging mode (terminal control) setting determines the averaging action.

Factory Preset: 15

Range: 1 to 10,000

Remarks: You must be in the GSM, EDGE mode to use this command.
Use INSTRument:SELEct to set the mode.

History: E4406A:
Version A.03.00 or later

Transmit Band Spurs—Averaging State

[:SENSe] : TSPur : AVERAge [:STATe] OFF | ON | 0 | 1

[:SENSe] : TSPur : AVERAge [:STATe] ?

Turn averaging on or off.

Factory Preset: ON

Remarks: You must be in the GSM, EDGE mode to use this command.
Use INSTRument:SELEct to set the mode.

History: E4406A:
Version A.03.00 or later

Transmit Band Spurs—Averaging Termination Control

[:SENSe] : TSPur : AVERAge : TCONtrol EXPonential | REPEat

[:SENSe] : TSPur : AVERAge : TCONtrol ?

Select the type of termination control used for the averaging function. This determines the averaging action after the specified number of data acquisitions (average count) is reached.

SENSe Subsystem

EXPOnential - Each successive data acquisition after the average count is reached, is exponentially weighted and combined with the existing average.

REPeat - After reaching the average count, the averaging is reset and a new average is started.

Factory Preset: REPeat

Remarks: You must be in the GSM, EDGE mode to use this command.
Use INSTRument:SElect to set the mode.

History: E4406A:
Version A.03.00 or later

Transmit Band Spurs—Averaging Type

[:SENSe] :TSPur :AVERAge :TYPE LOG | MAXimum | RMS

[:SENSe] :TSPur :AVERAge :TYPE?

Select the type of averaging.

LOG - The log of the power is averaged. (This is also known as video averaging.)

MAXimum - The maximum values are retained.

RMS - The power is averaged, providing the rms of the voltage.

Factory Preset: MAXimum

Remarks: You must be in the GSM, EDGE mode to use this command.
Use INSTRument:SElect to set the mode.

History: E4406A:
Version A.03.00 or later

Transmit Band Spurs—Type

[:SENSe] :TSPur :TYPE EXAMine | FULL

[:SENSe] :TSPur :TYPE?

Select the measurement type.

EXAMine - measures spurs in all the valid segments and then displays the segment that has the worst spur

FULL - continuously measures the spurs in all the valid segments

Factory Preset: FULL

Remarks: You must be in the GSM, EDGE mode to use this command.
Use INSTRument:SElect to set the mode.

History: E4406A:

Version A.03.00 or later

Terminal Modulation Accuracy Measurement

Commands for querying the terminal modulation accuracy measurement results and for setting to the default values are found in the “MEASure Group of Commands” on page 193.

Terminal Modulation Accuracy Measurement–Active Code Channel

```
[ :SENSe ] :TRHO :ACODE AUTO | COMBination | PREDeFined
```

```
[ :SENSe ] :TRHO :ACODE ?
```

Set the reverse link active code detection mode.

- AUTO - It is automatically detected (by internal algorithm) whether or not channel is active.
- COMBination - Channel specified by predefined (Pilot/DRC/ACK/Data) whether or not it is active automatically (by internal algorithm).
- PREDeFined - It is decided by predefined information (Pilot/DRC/ACK/Data) whether or not channel is active.

Factory Preset: AUTO

Remarks: You must be in the 1xEV-DO mode to use this command. Use INSTRument:SElect to set the mode.

Terminal Modulation Accuracy Measurement–ACK Channel Definition

```
[ :SENSe ] :TRHO :ACODE :ACK OFF | ON | 0 | 1
```

```
[ :SENSe ] :TRHO :ACODE :ACK ?
```

Set the reverse link ACK channel to active (On) or inactive (Off).

- On - Reverse link ACK is set to active.
- Off - Reverse link ACK is set to inactive.

Factory Preset: On

Remarks: You must be in the 1xEV-DO mode to use this command. Use INSTRument:SElect to set the mode.

Terminal Modulation Accuracy Measurement–Data Channel Definition

```
[ :SENSe ] :TRHO :ACODE :DATA OFF | ON | 0 | 1
```

```
[ :SENSe ] :TRHO :ACODE :DATA ?
```

Set the reverse link data channel to active (On) or inactive (Off).

- On - Reverse link data is set to active.

- Off - Reverse link data is set to inactive.

Factory Preset: On

Remarks: You must be in the 1xEV-DO mode to use this command. Use INSTRUMENT:SElect to set the mode.

Terminal Modulation Accuracy Measurement–DRC Channel Definition

[:SENSe] : TRHO : ACODe : DRC OFF | ON | 0 | 1

[:SENSe] : TRHO : ACODe : DRC ?

Set the reverse link DRC channel to active (On) or inactive (Off).

- On - Reverse link DRC is set to active.
- Off - Reverse link DRC is set to inactive.

Factory Preset: On

Remarks: You must be in the 1xEV-DO mode to use this command. Use INSTRUMENT:SElect to set the mode.

Terminal Modulation Accuracy Measurement–Pilot Channel Definition

[:SENSe] : TRHO : ACODe : PILot OFF | ON | 0 | 1

[:SENSe] : TRHO : ACODe : PILot ?

Set the reverse link pilot channel to active (On) or inactive (Off).

- On - Reverse link pilot is set to active.
- Off - Reverse link pilot is set to inactive.

Factory Preset: On

Remarks: You must be in the 1xEV-DO mode to use this command. Use INSTRUMENT:SElect to set the mode.

Terminal Modulation Accuracy Measurement–ADC Range

[:SENSe] : TRHO : ADC : RANGe

AUTO | APEak | APLOCK | NONE | P0 | P6 | P12 | P18 | P24 | M6

[:SENSe] : TRHO : ADC : RANGe ?

Select a ranging function for the ADC gain control. This is an advanced control that normally does not need to be changed. If you are measuring a CW signal, see the following description.

- AUTO - This is automatic ranging. For FFT spectrums the auto ranging should not be used. An exception to this is if you know that your signal is “bursty,”

SENSe Subsystem

then you can use auto to maximize the time domain dynamic range as long as you are not very interested in the FFT data.

- **APEak (Auto Peak)** - This is automatic ranging to the peak signal level. For CW signals the default of auto-peak ranging can be used. However, a better FFT measurement of the signal can be made by selecting one of the manual ranges available by specifying NONE, or P0 through P18. Auto peaking can cause the ADC gain to monotonically track the ranges down during the data capture. This tracking effect should be negligible for the FFT spectrum, but selecting a manual range solves this possibility. If the CW signal being measured is close to the auto-ranging threshold, the noise floor may shift as much as 6 dB every sweep.
- **APLock (Auto Peak Lock)** - This is automatic ranging locked to the peak signal level. For CW signals, auto-peak lock ranging may be used. It will find the ADC gain most appropriate for this particular signal and will not track the ranges as auto peak can. If the CW signal being measured is close to the auto-ranging threshold, the noise floor may shift as much as 6 dB every sweep. For “bursty” signals, auto peak lock ranging should not be used. Since the ADC range can often be locked to the wrong one (resulting in overloading the ADC) the measurement will fail.
- **NONE** - This turns off any auto-ranging without making any changes to the current setting. This is not applicable for use with an Agilent VSA having a 12-bit ADC Board).
- **P0 through P18, P24, M6** - Manually selects one of the ADC ranges that add 0 dB (P0) to 18 dB (P18) and –6 dB (M6), 24 dB (P24) to the fixed gain across the range. Manual ranging is best for CW signals. M6 and P24 are applicable only for Agilent VSA analyzers having a 14-bit ADC board.

Factory Preset: NONE for Agilent PSA analyzers, including Agilent VSA analyzers with the 14-bit ADC board.

M6 for Agilent VSA analyzers with the 12-bit ADC board.

Remarks: You must be in the 1xEV-DO mode to use this command. Use INSTRUMENT:SElect to set the mode.

Terminal Modulation Accuracy Measurement–Active Set Threshold

```
[ :SENSe ] :TRHO :ASET :THReshold <numeric>
```

```
[ :SENSe ] :TRHO :ASET :THReshold?
```

Set the Active Threshold level for the active channel identification function in dB.

Factory Preset: 0.0 dB

Range: –100.0 to 0.0 dB

Remarks: You must be in the 1xEV-DO mode to use this command. Use INSTRUMENT:SElect to set the mode.

Terminal Modulation Accuracy Measurement–Average Count

[:SENSe] :TRHO:AVERAge:COUNT <integer>

[:SENSe] :TRHO:AVERAge:COUNT?

Set the number of data acquisitions that will be averaged. After the specified number of average counts, the average mode (termination control) setting determines the average action.

Factory Preset: 10

Range: 1 to 10,000

Remarks: You must be in the 1xEV-DO mode to use this command. Use INSTRument:SELEct to set the mode.

Terminal Modulation Accuracy Measurement–Averaging State

[:SENSe] :TRHO:AVERAge[:STATe] OFF | ON | 0 | 1

[:SENSe] :TRHO:AVERAge[:STATe]?

Turn average On or Off.

Factory Preset: On

Remarks: You must be in the 1xEV-DO mode to use this command. Use INSTRument:SELEct to set the mode.

Terminal Modulation Accuracy Measurement–Averaging Termination Control

[:SENSe] :TRHO:AVERAge:TCONTRol EXPonential | REPeat

[:SENSe] :TRHO:AVERAge:TCONTRol?

Select the type of termination control used for averaging. This determines the averaging action after the specified number of data acquisitions (average count) is reached.

- EXPonential - After the average count is reached each successive data acquisition is exponentially weighted and combined with the existing average.
- REPeat - After the average count is reached the averaging is reset and a new average is started.

Factory Preset: REPeat

Remarks: You must be in the 1xEV-DO mode to use this command. Use INSTRument:SELEct to set the mode.

SENSe Subsystem

Terminal Modulation Accuracy Measurement–Chip Rate

[:SENSe] :TRHO:CRATe <freq>

[:SENSe] :TRHO:CRATe?

Set the chip rate.

Factory Preset: 1.2288 MHz

Range: 1.10592 MHz to 1.35168 MHz (default $\pm 10\%$)

Resolution: 1 Hz

Step: 1 kHz

Remarks: You must be in the 1xEV-DO mode to use this command. Use INSTRument:SElect to set the mode.

Terminal Modulation Accuracy Measurement–Averaging State

[:SENSe] :TRHO:AVERAge [:STATe] OFF | ON | 0 | 1

[:SENSe] :TRHO:AVERAge [:STATe]?

Turn average On or Off.

Factory Preset: On

Remarks: You must be in the 1xEV-DO mode to use this command. Use INSTRument:SElect to set the mode.

Terminal Modulation Accuracy Measurement– Spectrum Normal/Invert

[:SENSe] :TRHO:SPECTrum NORMAl | INVert

[:SENSe] :TRHO:SPECTrum?

Select normal or inverted spectrum for demodulation related measurements.

- NORMAl - normal
- INVert - The Upper and Lower sidebands are reversed in position

Factory Preset: NORMAl

Remarks: You must be in the 1xEV-DO mode to use this command. Use INSTRument:SElect to set the mode.

Terminal Modulation Accuracy Measurement–I Long Code Mask

[:SENSe] :TRHO:SYNC:ILCMask <long_integer>

[:SENSe] :TRHO:SYNC:ILCMask?

Set the I long code mask for RHO.

Factory Preset: 0x0

Range: 0x0 to 0x3ff ffff ffff (42 bits)

Remarks: You must be in the 1xEV-DO mode to use this command. Use INSTRUMENT:SElect to set the mode.

Terminal Modulation Accuracy Measurement–Q Long Code Mask

[:SENSe] :TRHO:SYNC:QLCMask <long_integer>

[:SENSe] :TRHO:SYNC:QLCMask?

Set the Qlong code mask for RHO.

Factory Preset: 0x0

Range: 0x0 to 0x3ff ffff ffff (42 bits)

Remarks: You must be in the 1xEV-DO mode to use this command. Use INSTRUMENT:SElect to set the mode.

Terminal Modulation Accuracy Measurement Trigger Source

[:SENSe] :TRHO:TRIGger:SOURce

EXTErnal[1] | EXTErnal2 | IMMEDIATE | RFBurst | IF | FRAME

[:SENSe] :TRHO:TRIGger:SOURce?

Set the trigger source used to control the data acquisitions.

- EXTErnal[1] - Front panel external trigger input
- EXTErnal2 - Rear panel external trigger input
- IMMEDIATE - The next data acquisition is immediately taken, capturing the signal asynchronously (also called Free Run).
- RFBurst - Internal wideband RF burst envelope trigger that has automatic level control for periodic burst signals.
- IF - Internal IF envelope trigger.
- FRAME - Internal frame trigger.

Factory Preset: IMMEDIATE

Remarks: You must be in the 1xEV-DO mode to use this command. Use INSTRUMENT:SElect to set the mode.

Transmit Power Measurement

Commands for querying the transmit power measurement results and for setting to the default values are found in the “MEASure Group of Commands” on page 193. The equivalent front panel keys for the parameters described in the following commands, are found under the **Meas Setup** key, after the **Transmit Power** measurement has been selected from the **MEASURE** key menu.

Transmit Power—Number of Bursts Averaged

[:SENSe] :TXPower :AVERAge :COUNT <integer>

[:SENSe] :TXPower :AVERAge :COUNT?

Set the number of bursts that will be averaged. After the specified number of bursts (average counts), the averaging mode (terminal control) setting determines the averaging action.

Factory Preset: 50

Range: 1 to 10,000

Remarks: You must be in the GSM, EDGE mode to use this command.
Use INSTRument:SELEct to set the mode.

Transmit Power—Averaging State

[:SENSe] :TXPower :AVERAge [:STATE] OFF | ON | 0 | 1

[:SENSe] :TXPower :AVERAge [:STATE]?

Turn averaging on or off.

Factory Preset: ON

Remarks: You must be in the GSM, EDGE mode to use this command.
Use INSTRument:SELEct to set the mode.

Transmit Power—Averaging Mode

[:SENSe] :TXPower :AVERAge :TCONTRol EXPonential | REPEAT

[:SENSe] :TXPower :AVERAge :TCONTRol?

Select the type of termination control used for the averaging function. This determines the averaging action after the specified number of frames (average count) is reached.

EXPonential - Each successive data acquisition after the average count is reached, is exponentially weighted and combined with the existing average.

REPEAT - After reaching the average count, the averaging is reset and a new average is started.

Factory Preset: EXPOnential

Remarks: You must be in the GSM, EDGE mode to use this command.
Use INSTRument:SElect to set the mode.

Transmit Power—Averaging Type

[:SENSe] :TXPower :AVERAge :TYPE | LOG | MAX | MIN | RMS

[:SENSe] :TXPower :AVERAge :TYPE?

Select the type of averaging to be performed.

- LOG - The log of the power is averaged. (This is also known as video averaging.)
- MAXimum - The maximum values are retained.
- MINimum - The minimum values are retained.
- RMS - The power is averaged, providing the rms of the voltage.

Factory Preset: RMS

Remarks: You must be in the GSM, EDGE mode to use this command.
Use INSTRument:SElect to set the mode.

Transmit Power—Resolution BW

[:SENSe] :TXPower :BANDwidth | BWIDth [:RESolution] <freq>

[:SENSe] :TXPower :BANDwidth | BWIDth [:RESolution]?

Set the resolution BW. This is an advanced control that normally does not need to be changed. Setting it to a value other than the factory default, may cause invalid measurement results.

Factory Preset: 500 kHz

Range: 1 kHz to 5 MHz

Default Unit: Hz

Remarks: You must be in the GSM, EDGE mode to use this command.
Use INSTRument:SElect to set the mode.

Transmit Power—Resolution BW Filter Type

**[:SENSe] :TXPower :BANDwidth | BWIDth [:RESolution] :TYPE
FLAT | GAUSSian**

[:SENSe] :TXPower :BANDwidth | BWIDth [:RESolution] :TYPE?

Select the type of resolution BW filter. This is an advanced control that normally

SENSe Subsystem

does not need to be changed. Setting this to a value other than the factory default, may cause invalid measurement results.

Flat top (FLAT) - a filter with a flat amplitude response, which provides the best amplitude accuracy.

GAUSSian - a filter with Gaussian characteristics, which provides the best pulse response.

Factory Preset: GAUSSian

Remarks: You must be in the GSM, EDGE mode to use this command.
Use INSTRument:SELEct to set the mode.

Transmit Power—Sweep Time

[:SENSe] :TXPower :SWEep :TIME <integer>

[:SENSe] :TXPower :SWEep :TIME?

Set the number of slots which are used in each data acquisition. Each slot is approximately equal to 600 ms.

Factory Preset: 1

Range: 1 to 50 time slots (for resolution BW = 500 kHz)

Remarks: You must be in the GSM, EDGE or Service mode to use this command. Use INSTRument:SELEct to set the mode.

Transmit Power—Threshold Level

[:SENSe] :TXPower :THReshold <power>

[:SENSe] :TXPower :THReshold?

Set the amplitude threshold level. Only the data above the threshold level is kept and used to compute the average transmit carrier power.

Factory Preset: -6.0 dB

Range: -100 dB to 0 dB, for relative mode
-100 dBm to +30 dB, for absolute mode

Default Unit: dB for relative mode
dBm for absolute mode

Remarks: The command (SENSe:TXPower:THReshold:TYPE ABSolute|RELative) determines whether this command is setting an absolute or a relative power level.

You must be in the GSM, EDGE mode to use this command.
Use INSTRument:SELEct to set the mode.

Transmit Power—Threshold Type

```
[ :SENSe ]:TXPower:THReshold:TYPE ABSolute|RELative
```

```
[ :SENSe ]:TXPower:THReshold:TYPE?
```

Select auto or manual control of the threshold level.

ABSolute - threshold value is set to an absolute power level

RELative - threshold value is set relative to the reference

Factory Preset: RELative

Remarks: You must be in the GSM, EDGE mode to use this command.
Use INSTRument:SElect to set the mode.

Transmit Power—Trigger Source

```
[ :SENSe ]:TXPower:TRIGger:SOURce
```

```
EXTErnal[1]|EXTErnal2|IF|IMMEdiate|RFBurst
```

```
[ :SENSe ]:TXPower:TRIGger:SOURce?
```

Select the trigger source used to control the data acquisitions.

EXTErnal 1 - front panel external trigger input

EXTErnal 2 - rear panel external trigger input

IF - internal IF envelope (video) trigger

IMMEdiate - the next data acquisition is immediately taken (also called free run)

RFBurst - wideband RF burst envelope trigger that has automatic level control for periodic burst signals.

Factory Preset: RFBurst

Remarks: You must be in the GSM, EDGE mode to use this command.
Use INSTRument:SElect to set the mode.

Waveform (Time-Domain) Measurement

Commands for querying the waveform measurement results and for setting to the default values are found in the “MEASURE Group of Commands” on page 193. The equivalent front panel keys for the parameters described in the following commands, are found under the **Meas Setup** key, after the **Waveform (Time Domain)** measurement has been selected from the **MEASURE** key menu.

Waveform—Data Acquisition Packing

```
[ :SENSE ] :WAVEform:ACQuisition:PACKing AUTO | LONG | MEdium | SHORt
```

```
[ :SENSe ] :WAVEform:ACQuisition:PACKing?
```

This is an advanced control that normally does not need to be changed.

Factory Preset: AUTO

Remarks: To use this command for E4406A, the appropriate mode should be selected with INSTRUMENT:SElect.

For PSA you must be in the Basic, cdmaOne, cdma2000, 1xEV-DO, W-CDMA, GSM, EDGE, NADC, or PDC mode to use this command. Use INSTRUMENT:SElect to set the mode.

Waveform—ADC Dither State

```
[ :SENSE ] :WAVEform:ADC:DITHer [ :STATe ] OFF | ON | 0 | 1
```

```
[ :SENSe ] :WAVEform:ADC:DITHer [ :STATe ]?
```

This is an Advanced control that normally does not need to be changed.

Factory Preset: OFF

Remarks: To use this command for E4406A, the appropriate mode should be selected with INSTRUMENT:SElect.

For PSA you must be in the Basic, cdmaOne, cdma2000, 1xEV-DO, W-CDMA, GSM, EDGE, NADC, or PDC mode to use this command. Use INSTRUMENT:SElect to set the mode.

Waveform—Pre-ADC Bandpass Filter

```
[ :SENSE ] :WAVEform:ADC:FILTer [ :STATe ] OFF | ON | 0 | 1
```

```
[ :SENSe ] :WAVEform:ADC:FILTer [ :STATe ]?
```

Turn the pre-ADC bandpass filter on or off. This is an Advanced control that normally does not need to be changed.

Preset: OFF

Remarks: To use this command for E4406A, the appropriate mode should

be selected with INSTRument:SElect.

For PSA you must be in the Basic, cdmaOne, cdma2000, 1xEV-DO, W-CDMA, GSM, EDGE, NADC, or PDC mode to use this command. Use INSTRument:SElect to set the mode.

Waveform—ADC Range

E4406A

[:SENSe] :WAVEform:ADC:RANGe

AUTO | APEak | APLock | GROund | M6 | P0 | P6 | P12 | P18 | P24

PSA

[:SENSe] :WAVEform:ADC:RANGe

AUTO | APEak | APLock | GROund | NONE | P0 | P6 | P12 | P18

[:SENSe] :WAVEform:ADC:RANGe?

Select the range for the gain-ranging that is done in front of the ADC. This is an Advanced control that normally does not need to be changed.

AUTO - automatic range

Auto Peak (APEak) - automatically peak the range

Auto Peak Lock (APLock)- automatically peak lock the range

GROund - ground

NONE - (PSA) turn off auto-ranging without making any changes to the current setting.

M6 - (E4406A) subtracts 6 dB of fixed gain across the range

P0 to P18 - (PSA) adds 0 to 18 dB of fixed gain across the range

P0 to P24 - (E4406A) adds 0 to 24 dB of fixed gain across the range

Factory Preset: AUTO

Remarks: To use this command for E4406A, the appropriate mode should be selected with INSTRument:SElect.

For PSA you must be in the Basic, cdmaOne, cdma2000, 1xEV-DO, W-CDMA, GSM, EDGE, NADC, or PDC mode to use this command. Use INSTRument:SElect to set the mode.

Waveform - Query Aperture Setting

[:SENSe] :WAVEform:APERTure?

Returns the waveform sample period (aperture) based on current resolution bandwidth, filter type, and decimation factor. Sample rate is the reciprocal of period.

SENSE Subsystem

Remarks: To use this command for E4406A, the appropriate mode should be selected with INSTRUMENT:SELECT.

For PSA you must be in the Basic, cdmaOne, cdma2000, 1xEV-DO, W-CDMA, GSM, EDGE, NADC, or PDC mode to use this command. Use INSTRUMENT:SELECT to set the mode.

Waveform—Number of Averages

[:SENSE] :WAVEform:AVERage:COUNT <integer>

[:SENSE] :WAVEform:AVERage:COUNT?

Set the number of sweeps that will be averaged. After the specified number of sweeps (average counts), the averaging mode (terminal control) setting determines the averaging action.

Factory Preset: 10

Range: 1 to 10,000

Remarks: To use this command for E4406A, the appropriate mode should be selected with INSTRUMENT:SELECT.

For PSA you must be in the Basic, cdmaOne, cdma2000, 1xEV-DO, W-CDMA, GSM, EDGE, NADC, or PDC mode to use this command. Use INSTRUMENT:SELECT to set the mode.

Waveform—Averaging State

[:SENSE] :WAVEform:AVERage[:STATE] OFF|ON|0|1

[:SENSE] :WAVEform:AVERage[:STATE]?

Turn averaging on or off.

Factory Preset: OFF

Remarks: To use this command for E4406A, the appropriate mode should be selected with INSTRUMENT:SELECT.

For PSA you must be in the Basic, cdmaOne, cdma2000, 1xEV-DO, W-CDMA, GSM, EDGE, NADC, or PDC mode to use this command. Use INSTRUMENT:SELECT to set the mode.

Waveform—Averaging Mode

[:SENSE] :WAVEform:AVERage:TCONTROL EXPONential|REPEAT

[:SENSE] :WAVEform:AVERage:TCONTROL?

Select the type of termination control used for the averaging function. This

determines the averaging action after the specified number of ‘sweeps’ (average count) is reached.

EXPOnential - Each successive data acquisition after the average count is reached, is exponentially weighted and combined with the existing average.

REPeat - After reaching the average count, the averaging is reset and a new average is started.

Factory Preset: EXPOnential

Remarks: To use this command for E4406A, the appropriate mode should be selected with INSTRument:SElect.

For PSA you must be in the Basic, cdmaOne, cdma2000, 1xEV-DO, W-CDMA, GSM, EDGE, NADC, or PDC mode to use this command. Use INSTRument:SElect to set the mode.

Waveform—Averaging Type

```
[ :SENSe ] :WAVeform:AVERAge :TYPE
LOG | MAXimum | MINimum | RMS | SCALar
```

```
[ :SENSe ] :WAVeform:AVERAge :TYPE?
```

Select the type of averaging.

LOG - The log of the power is averaged. (This is also known as video averaging.)

MAXimum - The maximum values are retained.

MINimum - The minimum values are retained.

RMS - The power is averaged, providing the rms of the voltage.

Factory Preset: RMS

Remarks: To use this command for E4406A, the appropriate mode should be selected with INSTRument:SElect.

For PSA you must be in the Basic, cdmaOne, cdma2000, 1xEV-DO, W-CDMA, GSM, EDGE, NADC, or PDC mode to use this command. Use INSTRument:SElect to set the mode.

Waveform—Resolution BW

```
[ :SENSe ] :WAVeform:BANDwidth | BWIDth [ :RESolution ] <freq>
```

```
[ :SENSe ] :WAVeform:BANDwidth | BWIDth [ :RESolution ]?
```

Set the resolution bandwidth. This value is ignored if the function is auto-coupled.

Factory Preset: 100.0 kHz for NADC, PDC, cdma2000, W-CDMA, Basic, Service (E4406A)

SENSE Subsystem

500.0 kHz for GSM
2.0 MHz for cdmaOne

Range: 1.0 kHz to 8.0 MHz when
[:SENSE]:WAVEform:BANDwidth|BWIDth
[:RESolution]:TYPE GAUSSian

1.0 kHz to 10.0 MHz when
[:SENSE]:WAVEform:BANDwidth|BWIDth
[:RESolution]:TYPE FLATtop

Remarks: To use this command for E4406A, the appropriate mode should be selected with INSTRUMENT:SElect.

For PSA you must be in the Basic, cdmaOne, cdma2000, 1xEV-DO, W-CDMA, GSM, EDGE, NADC, or PDC mode to use this command. Use INSTRUMENT:SElect to set the mode.

Bandwidths > 6.7 MHz will require a slight increase in measurement time.

Waveform - Query Actual Resolution Bandwidth

[:SENSE]:WAVEform:BANDwidth:RESolution]:ACTual?

Due to memory constraints the actual resolution bandwidth value may vary from the value entered by the user. For most applications the resulting difference in value is inconsequential but for some it is necessary to know the actual value; this query retrieves the actual resolution bandwidth value.

Remarks: To use this command for E4406A, the appropriate mode should be selected with INSTRUMENT:SElect.

For PSA you must be in the Basic, cdmaOne, cdma2000, 1xEV-DO, W-CDMA, GSM, EDGE, NADC, or PDC mode to use this command. Use INSTRUMENT:SElect to set the mode.

History: E4406A:
Version A.05.00 or later

Waveform—Resolution BW Filter Type

**[:SENSE]:WAVEform:BANDwidth|BWIDth[:RESolution]:TYPE
FLATtop|GAUSSian**

[:SENSE]:WAVEform:BANDwidth|BWIDth[:RESolution]:TYPE?

Select the type of Resolution BW filter that is used. This is an Advanced control that normally does not need to be changed.

FLATtop - a filter with a flat amplitude response, which provides the best amplitude accuracy.

GAUSSian - a filter with Gaussian characteristics, which provides the best pulse response.

Factory Preset: GAUSSian

Remarks: To use this command for E4406A, the appropriate mode should be selected with INSTRUMENT:SElect.

For PSA you must be in the Basic, cdmaOne, cdma2000, 1xEV-DO, W-CDMA, GSM, EDGE, NADC, or PDC mode to use this command. Use INSTRUMENT:SElect to set the mode.

Waveform—Decimation of Waveform Display

[:SENSe] :WAVEform:DECimate [:FACTor] <integer>

[:SENSe] :WAVEform:DECimate [:FACTor] ?

Set the amount of data decimation done on the IQ data stream. For example, if 4 is selected, three out of every four data points will be thrown away. So every 4th data point will be kept.

Factory Preset: 1

Range: 1 to 4

Remarks: To use this command for E4406A, the appropriate mode should be selected with INSTRUMENT:SElect.

For PSA you must be in the Basic, cdmaOne, cdma2000, 1xEV-DO, W-CDMA, GSM, EDGE, NADC, or PDC mode to use this command. Use INSTRUMENT:SElect to set the mode.

Waveform—Control Decimation of Waveform Display

[:SENSe] :WAVEform:DECimate:STATE OFF | ON | 0 | 1

[:SENSe] :WAVEform:DECimate:STATE ?

Set the amount of data decimation done by the hardware in order to decrease the number of acquired points in a long capture time. This is the amount of data that the measurement ignores.

Factory Preset: OFF

Remarks: To use this command for E4406A, the appropriate mode should be selected with INSTRUMENT:SElect.

For PSA you must be in the Basic, cdmaOne, cdma2000, 1xEV-DO, W-CDMA, GSM, EDGE, NADC, or PDC mode to use this command. Use INSTRUMENT:SElect to set the mode.

SENSE Subsystem

Waveform—Sweep (Acquisition) Time

[:SENSE] :WAVEform :SWEep :TIME <time>

[:SENSE] :WAVEform :SWEep :TIME?

Set the measurement acquisition time. It is used to specify the length of the time capture record.

Factory Preset: 2.0 ms

10.0 ms, for NADC, PDC

15.0 ms, for iDEN mode (E4406A)

Range: 1 μ s to 100 s

Default Unit: seconds

Remarks: To use this command for E4406A, the appropriate mode should be selected with INSTRUMENT:SElect.

For PSA you must be in the Basic, cdmaOne, cdma2000, 1xEV-DO, W-CDMA, GSM, EDGE, NADC, or PDC mode to use this command. Use INSTRUMENT:SElect to set the mode.

Waveform—Trigger Source

[:SENSE] :WAVEform :TRIGger :SOURce EXTErnal [1] | EXTErnal2 | FRAME | IF | IMMEDIATE | LINE | RFBurst

[:SENSE] :WAVEform :TRIGger :SOURce?

Select the trigger source used to control the data acquisitions.

EXTErnal 1 - front panel external trigger input

EXTErnal 2 - rear panel external trigger input

FRAME - internal frame timer from front panel input

IF - internal IF envelope (video) trigger

IMMEDIATE - the next data acquisition is immediately taken (also called free run)

LINE - internal line trigger

RFBurst - wideband RF burst envelope trigger that has automatic level control for periodic burst signals

Factory Preset: IMMEDIATE (free run), for Basic, cdmaOne, NADC, PDC mode

RFBurst, for GSM, iDEN (E4406A) modes

Remarks: To use this command for E4406A, the appropriate mode should be selected with INSTRUMENT:SElect.

For PSA you must be in the Basic, cdmaOne, cdma2000, 1xEV-DO, W-CDMA, GSM, EDGE, NADC, or PDC mode to use this command. Use INSTRument:SElect to set the mode.

SENSe Subsystem

STATus Subsystem

The STATus subsystem controls the SCPI-defined instrument-status reporting structures. Each status register has a set of five commands used for querying or masking that particular register.

Numeric values for bit patterns can be entered using decimal or hexadecimal representations. (i.e. 0 to 32767 is equivalent to #H0 to #H7FFF) See the SCPI Basics information about using bit patterns for variable parameters.

Operation Register

Operation Condition Query

:STATus:OPERation:CONDition?

This query returns the decimal value of the sum of the bits in the Status Operation Condition register.

NOTE

The data in this register is continuously updated and reflects the current conditions.

Key Type: There is no equivalent front panel key.

Operation Enable

:STATus:OPERation:ENABle <integer>

:STATus:OPERation:ENABle?

This command determines which bits in the Operation Event register, will set the Operation Status Summary bit (bit 7) in the Status Byte Register. The variable <number> is the sum of the decimal values of the bits you want to enable.

NOTE

The preset condition is to have all bits in this enable register set to 0. To have any Operation Events reported to the Status Byte Register, one or more bits need to be set to 1.

Key Type: There is no equivalent front panel key.

Factory Preset: 1

Range: 0 to 32767

Operation Event Query

:STATus:OPERation[:EVENT]?

This query returns the decimal value of the sum of the bits in the Operation Event register.

NOTE

The register requires that the associated PTR or NTR filters be set before a condition register bit can set a bit in the event register.

The data in this register is latched until it is queried. Once queried, the register is cleared.

Key Type: There is no equivalent front panel key.

Operation Negative Transition

:STATus:OPERation:NTRansition <integer>

:STATus:OPERation:NTRansition?

This command determines which bits in the Operation Condition register will set the corresponding bit in the Operation Event register when the condition register bit has a negative transition (1 to 0). The variable <number> is the sum of the decimal values of the bits that you want to enable.

Key Type: There is no equivalent front panel key.

Factory Preset: 0

Range: 0 to 32767

Operation Positive Transition

:STATus:OPERation:PTRansition <integer>

:STATus:OPERation:PTRansition?

This command determines which bits in the Operation Condition register will set the corresponding bit in the Operation Event register when the condition register bit has a positive transition (0 to 1). The variable <number> is the sum of the decimal values of the bits that you want to enable.

Key Type: There is no equivalent front panel key.

Factory Preset: 32767 (all 1's)

Range: 0 to 32767

Preset the Status Byte

:STATus:PRESet

Sets bits in most of the enable and transition registers to their default state. It presets all the Transition Filters, Enable Registers, and the Error/Event Queue Enable. It has no effect on Event Registers, Error/Event QUEUE, IEEE 488.2 ESE, and SRE Registers as described in IEEE Standard 488.2-1992, *IEEE Standard*

Codes, Formats, Protocols and Common Commands for Use with ANSI/IEEE Std 488.1-1987. New York, NY, 1992.

Key Type: There is no equivalent front panel key.

Questionable Register

Questionable Condition

:STATus:QUEStionable:CONDition?

This query returns the decimal value of the sum of the bits in the Questionable Condition register.

NOTE The data in this register is continuously updated and reflects the current conditions.

Key Type: There is no equivalent front panel key.

Questionable Enable

:STATus:QUEStionable:ENABle <number>

:STATus:QUEStionable:ENABle?

This command determines which bits in the Questionable Event register will set the Questionable Status Summary bit (bit3) in the Status Byte Register. The variable <number> is the sum of the decimal values of the bits you want to enable.

NOTE The preset condition is all bits in this enable register set to 0. To have any Questionable Events reported to the Status Byte Register, one or more bits need to be set to 1. It is recommended that all bits be enabled in this register. The Status Byte Event Register should be queried after each measurement to check the Questionable Status Summary (bit 3). If it is equal to 1, a condition during the test may have made the test results invalid. If it is equal to 0, this indicates that no hardware problem or measurement problem was detected by the analyzer.

Key Type: There is no equivalent front panel key.

Factory Preset: 0

Range: 0 to 32767

Questionable Event Query

:STATus:QUEStionable[:EVENT]?

This query returns the decimal value of the sum of the bits in the Questionable Event register.

NOTE

The register requires that the associated PTR or NTR filters be set before a condition register bit can set a bit in the event register.

The data in this register is latched until it is queried. Once queried, the register is cleared.

Key Type: There is no equivalent front panel key.

Questionable Negative Transition

:STATUS:QUESTIONABLE:NTRANSITION <number>

:STATUS:QUESTIONABLE:NTRANSITION?

This command determines which bits in the Questionable Condition register will set the corresponding bit in the Questionable Event register when the condition register bit has a negative transition (1 to 0). The variable <number> is the sum of the decimal values of the bits that you want to enable.

Key Type: There is no equivalent front panel key.

Factory Preset: 0

Range: 0 to 32767

Questionable Positive Transition

:STATUS:QUESTIONABLE:PTRANSITION <number>

:STATUS:QUESTIONABLE:PTRANSITION?

This command determines which bits in the Questionable Condition register will set the corresponding bit in the Questionable Event register when the condition register bit has a positive transition (0 to 1). The variable <number> is the sum of the decimal values of the bits that you want to enable.

Key Type: There is no equivalent front panel key.

Factory Preset: 32767 (all 1's)

Range: 0 to 32767

Questionable Calibration Register

Questionable Calibration Condition

:STATUS:QUESTIONABLE:CALIBRATION:CONDITION?

This query returns the decimal value of the sum of the bits in the Questionable Calibration Condition register.

NOTE The data in this register is continuously updated and reflects the current conditions.

Key Type: There is no equivalent front panel key.

Questionable Calibration Enable

:STATus:QUEStionable:CALibration:ENABle <number>

:STATus:QUEStionable:CALibration:ENABle?

This command determines which bits in the Questionable Calibration Condition Register will set bits in the Questionable Calibration Event register, which also sets the Calibration Summary bit (bit 8) in the Questionable Register. The variable <number> is the sum of the decimal values of the bits you want to enable.

Key Type: There is no equivalent front panel key.

Example STAT:QUES:CAL:ENABLE 16384 could be used if you have turned off the automatic alignment and you want to query if an alignment is needed.

Factory Preset: 32767 (all 1's)

Range: 0 to 32767

Questionable Calibration Event Query

:STATus:QUEStionable:CALibration[:EVENT]?

This query returns the decimal value of the sum of the bits in the Questionable Calibration Event register.

NOTE The register requires that the associated PTR or NTR filters be set before a condition register bit can set a bit in the event register.

The data in this register is latched until it is queried. Once queried, the register is cleared.

Key Type: There is no equivalent front panel key.

Questionable Calibration Negative Transition

:STATus:QUEStionable:CALibration:NTRansition <number>

:STATus:QUEStionable:CALibration:NTRansition?

This command determines which bits in the Questionable Calibration Condition register will set the corresponding bit in the Questionable Calibration Event register when the condition register bit has a negative transition (1 to 0). The variable <number> is the sum of the decimal values of the bits that you want to

STATus Subsystem

enable.

Key Type: There is no equivalent front panel key.

Factory Preset: 0

Range: 0 to 32767

Questionable Calibration Positive Transition

:STATus:QUEStionable:CALibration:PTRansition <number>

:STATus:QUEStionable:CALibration:PTRansition?

This command determines which bits in the Questionable Calibration Condition register will set the corresponding bit in the Questionable Calibration Event register when the condition register bit has a positive transition (0 to 1). The variable <number> is the sum of the decimal values of the bits that you want to enable.

Key Type: There is no equivalent front panel key.

Factory Preset: 32767 (all 1's)

Range: 0 to 32767

Questionable Frequency Register

Questionable Frequency Condition

:STATus:QUEStionable:FREQuency:CONDition?

This query returns the decimal value of the sum of the bits in the Questionable Frequency Condition register.

NOTE

The data in this register is continuously updated and reflects the current conditions.

Key Type: There is no equivalent front panel key.

Questionable Frequency Enable

:STATus:QUEStionable:FREQuency:ENABle <number>

:STATus:QUEStionable:FREQuency:ENABle?

This command determines which bits in the Questionable Frequency Condition Register will set bits in the Questionable Frequency Event register, which also sets the Frequency Summary bit (bit 5) in the Questionable Register. The variable <number> is the sum of the decimal values of the bits you want to enable.

Key Type: There is no equivalent front panel key.

Factory Preset: 32767 (all 1's)

Range: 0 to 32767

Questionable Frequency Event Query

:STATus:QUEStionable:FREQuency[:EVENT]?

This query returns the decimal value of the sum of the bits in the Questionable Frequency Event register.

NOTE

The register requires that the associated PTR or NTR filters be set before a condition register bit can set a bit in the event register.

The data in this register is latched until it is queried. Once queried, the register is cleared.

Key Type: There is no equivalent front panel key.

Questionable Frequency Negative Transition

:STATus:QUEStionable:FREQuency:NTRansition <number>

:STATus:QUEStionable:FREQuency:NTRansition?

This command determines which bits in the Questionable Frequency Condition register will set the corresponding bit in the Questionable Frequency Event register when the condition register bit has a negative transition (1 to 0). The variable <number> is the sum of the decimal values of the bits that you want to enable.

Key Type: There is no equivalent front panel key.

Factory Preset: 0

Range: 0 to 32767

Questionable Frequency Positive Transition

:STATus:QUEStionable:FREQuency:PTRansition <number>

:STATus:QUEStionable:FREQuency:PTRansition?

This command determines which bits in the Questionable Frequency Condition register will set the corresponding bit in the Questionable Frequency Event register when the condition register bit has a positive transition (0 to 1). The variable <number> is the sum of the decimal values of the bits that you want to enable.

Key Type: There is no equivalent front panel key.

Factory Preset: 32767 (all 1's)

Range: 0 to 32767

Questionable Integrity Register

Questionable Integrity Condition

:STATUS:QUESTIONABLE:INTEGRITY:CONDITION?

This query returns the decimal value of the sum of the bits in the Questionable Integrity Condition register.

NOTE The data in this register is continuously updated and reflects the current conditions.

Key Type: There is no equivalent front panel key.

Questionable Integrity Enable

:STATUS:QUESTIONABLE:INTEGRITY:ENABLE <number>

:STATUS:QUESTIONABLE:INTEGRITY:ENABLE?

This command determines which bits in the Questionable Integrity Condition Register will set bits in the Questionable Integrity Event register, which also sets the Integrity Summary bit (bit 9) in the Questionable Register. The variable <number> is the sum of the decimal values of the bits you want to enable.

Key Type: There is no equivalent front panel key.

Factory Preset: 32767 (all 1's)

Range: 0 to 32767

Questionable Integrity Event Query

:STATUS:QUESTIONABLE:INTEGRITY[:EVENT]?

This query returns the decimal value of the sum of the bits in the Questionable Integrity Event register.

NOTE The register requires that the associated PTR or NTR filters be set before a condition register bit can set a bit in the event register.

The data in this register is latched until it is queried. Once queried, the register is cleared.

Key Type: There is no equivalent front panel key.

Questionable Integrity Negative Transition

:STATUS:QUESTIONABLE:INTEGRITY:NTRANSITION <number>

:STATUS:QUESTIONable:INTEGRity:NTRANSition?

This command determines which bits in the Questionable Integrity Condition register will set the corresponding bit in the Questionable Integrity Event register when the condition register bit has a negative transition (1 to 0)

The variable <number> is the sum of the decimal values of the bits that you want to enable.

Key Type: There is no equivalent front panel key.

Factory Preset: 0

Range: 0 to 32767

Questionable Integrity Positive Transition

:STATUS:QUESTIONable:INTEGRity:PTRANSition <number>

:STATUS:QUESTIONable:INTEGRity:PTRANSition?

This command determines which bits in the Questionable Integrity Condition register will set the corresponding bit in the Questionable Integrity Event register when the condition register bit has a positive transition (0 to 1). The variable <number> is the sum of the decimal values of the bits that you want to enable.

Key Type: There is no equivalent front panel key.

Factory Preset: 32767 (all 1's)

Range: 0 to 32767

Questionable Integrity Signal Register

Questionable Integrity Signal Condition

:STATUS:QUESTIONable:INTEGRity:SIGNal:CONDition?

This query returns the decimal value of the sum of the bits in the Questionable Integrity Signal Condition register.

NOTE The data in this register is continuously updated and reflects the current conditions.

Key Type: There is no equivalent front panel key.

Questionable Integrity Signal Enable

:STATUS:QUESTIONable:INTEGRity:SIGNal:ENABle <number>

:STATUS:QUESTIONable:INTEGRity:SIGNal:ENABle?

This command determines which bits in the Questionable Integrity Signal

STATUS Subsystem

Condition Register will set bits in the Questionable Integrity Signal Event register, which also sets the Integrity Summary bit (bit 9) in the Questionable Register. The variable <number> is the sum of the decimal values of the bits you want to enable.

Key Type: There is no equivalent front panel key.

Factory Preset: 32767 (all 1's)

Range: 0 to 32767

Questionable Integrity Signal Event Query

:STATUS:QUESTIONABLE:INTEGRITY:SIGNAL[:EVENT]?

This query returns the decimal value of the sum of the bits in the Questionable Integrity Signal Event register.

NOTE

The register requires that the associated PTR or NTR filters be set before a condition register bit can set a bit in the event register.

The data in this register is latched until it is queried. Once queried, the register is cleared.

Key Type: There is no equivalent front panel key.

Questionable Integrity Signal Negative Transition

:STATUS:QUESTIONABLE:INTEGRITY:SIGNAL:NTRANSITION <number>

:STATUS:QUESTIONABLE:INTEGRITY:SIGNAL:NTRANSITION?

This command determines which bits in the Questionable Integrity Signal Condition register will set the corresponding bit in the Questionable Integrity Signal Event register when the condition register bit has a negative transition (1 to 0). The variable <number> is the sum of the decimal values of the bits that you want to enable.

Key Type: There is no equivalent front panel key.

Factory Preset: 0

Range: 0 to 32767

Questionable Integrity Signal Positive Transition

:STATUS:QUESTIONABLE:INTEGRITY:SIGNAL:PTRANSITION <number>

:STATUS:QUESTIONABLE:INTEGRITY:SIGNAL:PTRANSITION?

This command determines which bits in the Questionable Integrity Signal Condition register will set the corresponding bit in the Questionable Integrity Signal Event register when the condition register bit has a positive transition (0 to

1). The variable <number> is the sum of the decimal values of the bits that you want to enable.

Key Type: There is no equivalent front panel key.

Factory Preset: 32767 (all 1's)

Range: 0 to 32767

Questionable Integrity Uncalibrated Register

Questionable Integrity Uncalibrated Condition

:STATus:QUEStionable:INTEgrity:UNCalibrated:CONDition?

This query returns the decimal value of the sum of the bits in the Questionable Integrity Uncalibrated Condition register.

NOTE

The data in this register is continuously updated and reflects the current conditions.

Key Type: There is no equivalent front panel key.

Questionable Integrity Uncalibrated Enable

:STATus:QUEStionable:INTEgrity:UNCalibrated:ENABLE

:STATus:QUEStionable:INTEgrity:UNCalibrated:ENABLE?

This command determines which bits in the Questionable Integrity Uncalibrated Condition Register will set bits in the Questionable Integrity Uncalibrated Event register, which also sets the Data Uncalibrated Summary bit (bit 3) in the Questionable Integrity Register. The variable <number> is the sum of the decimal values of the bits you want to enable.

Key Type: There is no equivalent front panel key.

Factory Preset: 32767 (all 1's)

Range: 0 to 32767

Questionable Integrity Uncalibrated Event Query

:STATus:QUEStionable:INTEgrity:UNCalibrated[:EVENT]?

This query returns the decimal value of the sum of the bits in the Questionable Integrity Uncalibrated Event register.

NOTE

The register requires that the associated PTR or NTR filters be set before a condition register bit can set a bit in the event register.

STATUS Subsystem

The data in this register is latched until it is queried. Once queried, the register is cleared.

Key Type: There is no equivalent front panel key.

Questionable Integrity Uncalibrated Negative Transition

:STATUS:QUESTIONable:INTEGRity:UNCalibrated:NTRansition <number>

:STATUS:QUESTIONable:INTEGRity:UNCalibrated:NTRansition?

This command determines which bits in the Questionable Integrity Uncalibrated Condition register will set the corresponding bit in the Questionable Integrity Uncalibrated Event register when the condition register bit has a negative transition (1 to 0). The variable <number> is the sum of the decimal values of the bits that you want to enable.

Key Type: There is no equivalent front panel key.

Factory Preset: 0

Range: 0 to 32767

Questionable Integrity Uncalibrated Positive Transition

:STATUS:QUESTIONable:INTEGRity:UNCalibrated:PTRansition <number>

:STATUS:QUESTIONable:INTEGRity:UNCalibrated:PTRansition?

This command determines which bits in the Questionable Integrity Uncalibrated Condition register will set the corresponding bit in the Questionable Integrity Uncalibrated Event register when the condition register bit has a positive transition (0 to 1). The variable <number> is the sum of the decimal values of the bits that you want to enable.

Key Type: There is no equivalent front panel key.

Factory Preset: 32767 (all 1's)

Range: 0 to 32767

Questionable Power Register

Questionable Power Condition

:STATUS:QUESTIONable:POWer:CONDition?

This query returns the decimal value of the sum of the bits in the Questionable Power Condition register.

NOTE The data in this register is continuously updated and reflects the current conditions.

Key Type: There is no equivalent front panel key.

Questionable Power Enable

:STATUS:QUESTIONable:POWER:ENABLE <number>

:STATUS:QUESTIONable:POWER:ENABLE?

This command determines which bits in the Questionable Power Condition Register will set bits in the Questionable Power Event register, which also sets the Power Summary bit (bit 3) in the Questionable Register. The variable <number> is the sum of the decimal values of the bits you want to enable.

Key Type: There is no equivalent front panel key.

Factory Preset: 32767 (all 1's)

Range: 0 to 32767

Questionable Power Event Query

:STATUS:QUESTIONable:POWER[:EVENT]?

This query returns the decimal value of the sum of the bits in the Questionable Power Event register.

NOTE The register requires that the associated PTR or NTR filters be set before a condition register bit can set a bit in the event register.

The data in this register is latched until it is queried. Once queried, the register is cleared.

Key Type: There is no equivalent front panel key.

Questionable Power Negative Transition

:STATUS:QUESTIONable:POWER:NTRansition <number>

:STATUS:QUESTIONable:POWER:NTRansition?

This command determines which bits in the Questionable Power Condition register will set the corresponding bit in the Questionable Power Event register when the condition register bit has a negative transition (1 to 0). The variable <number> is the sum of the decimal values of the bits that you want to enable.

Key Type: There is no equivalent front panel key.

Factory Preset: 0

STATUS Subsystem

Range: 0 to 32767

Questionable Power Positive Transition

:STATUS:QUESTIONable:POWER:PTRansition <number>

:STATUS:QUESTIONable:POWER:PTRansition?>

This command determines which bits in the Questionable Power Condition register will set the corresponding bit in the Questionable Power Event register when the condition register bit has a positive transition (0 to 1). The variable <number> is the sum of the decimal values of the bits that you want to enable.

Key Type: There is no equivalent front panel key.

Factory Preset: 32767 (all 1's)

Range: 0 to 32767

Questionable Temperature Register

Questionable Temperature Condition

:STATUS:QUESTIONable:TEMPerature:CONDition?

This query returns the decimal value of the sum of the bits in the Questionable Temperature Condition register.

NOTE

The data in this register is continuously updated and reflects the current conditions.

Key Type: There is no equivalent front panel key.

Questionable Temperature Enable

:STATUS:QUESTIONable:TEMPerature:ENABLE <number>

:STATUS:QUESTIONable:TEMPerature:ENABLE?

This command determines which bits in the Questionable Temperature Condition Register will set bits in the Questionable Temperature Event register, which also sets the Temperature Summary bit (bit 4) in the Questionable Register. The variable <number> is the sum of the decimal values of the bits you want to enable.

Key Type: There is no equivalent front panel key.

Factory Preset: 32767 (all 1's)

Range: 0 to 32767

Questionable Temperature Event Query

:STATUS:QUESTIONable:TEMPerature[:EVENT]?

This query returns the decimal value of the sum of the bits in the Questionable Temperature Event register.

NOTE

The register requires that the associated PTR or NTR filters be set before a condition register bit can set a bit in the event register.

The data in this register is latched until it is queried. Once queried, the register is cleared

Key Type: There is no equivalent front panel key.

Questionable Temperature Negative Transition

:STATUS:QUESTIONable:TEMPerature:NTRansition <number>

:STATUS:QUESTIONable:TEMPerature:NTRansition?

This command determines which bits in the Questionable Temperature Condition register will set the corresponding bit in the Questionable Temperature Event register when the condition register bit has a negative transition (1 to 0). The variable <number> is the sum of the decimal values of the bits that you want to enable.

Key Type: There is no equivalent front panel key.

Factory Preset: 0

Range: 0 to 32767

Questionable Temperature Positive Transition

:STATUS:QUESTIONable:TEMPerature:PTRansition <number>

:STATUS:QUESTIONable:TEMPerature:PTRansition?

This command determines which bits in the Questionable Temperature Condition register will set the corresponding bit in the Questionable Temperature Event register when the condition register bit has a positive transition (0 to 1). The variable <number> is the sum of the decimal values of the bits that you want to enable.

Key Type: There is no equivalent front panel key.

Factory Preset: 32767 (all 1's)

Range: 0 to 32767

STATUS Subsystem

SYSTem Subsystem

This subsystem is used to set the controls and parameters associated with the overall system communication. These are functions that are not related to instrument performance. Examples include functions for performing general housekeeping and functions related to setting global configurations.

GPIB Address

```
:SYSTem:COMMunicate:GPIB[:SELF]:ADDRess <integer>
```

```
:SYSTem:COMMunicate:GPIB[:SELF]:ADDRess?
```

Sets and queries the GPIB address.

Example: SYST:COMM:GPIB:ADDR 18

Factory Preset: The factory default is 18.

This function is persistent which means that it stays at the setting previously selected, even through a power cycle.

Range: Integer, 0 to 30

Example: SYST:COMM:GIPB:ADDRESS 18

Front Panel

Access: System, Config I/O, GPIB Addr

LAN IP Address with Host Name

```
:SYSTem:COMMunicate:LAN[:SELF]:IP <string>
```

```
:SYSTem:COMMunicate:LAN[:SELF]:IP?
```

Set the IP (internet protocol) address, domain name and node name for the instrument.

<string> is a string that contains: <IP address> <host name> as shown in the following example:

```
141.4.402.222 sigan
```

where: 141.4.402.222, is the IP address and sigan, is the host name.

Example: SYST:COMM:LAN:IP "22.121.44.45 analyz"

Front Panel

Access: System, Config I/O, Config LAN

Hardware Configuration Default

:SYSTem:CONFigure:DEFault

Resets all instrument functions to the factory defaults, including the persistent functions. Persistent functions are system settings that stay at their current settings even through instrument power-on, such as I/O bus addresses and preset preferences.

Example: SYST:CONF:DEF

Front Panel

Access: **System, Restore Sys Defaults**

Set Date

:SYSTem:DATE <year>,<month>,<day>

:SYSTem:DATE?

Sets the date of the real-time clock of the instrument.

Year - is a 4-digit integer

Month - is an integer from 1 to 12

Day - is an integer from 1 to 31 (depending on the month)

Example: SYST:DAT 2001,4,15

Front Panel

Access: **System, Time/Date, Set Date**

Error Information Query

:SYSTem:ERRor[:NEXT]?

This command queries the earliest entry in the error queue and then deletes that entry. It can be used to continuously monitor the error queue for the occurrence of an error.

*CLS clears the entire error queue.

Example: SYST:ERR?

Front Panel

Access: **System, Show Errors**

Locate SCPI Command Errors

:SYSTem:ERRor:VERBoSe OFF|ON|0|1

:SYSTem:ERRor:VERBoSe?

Adds additional information to the error messages returned by the SYSTem:ERRor? command. It indicates which SCPI command was executing when the error occurred and what about that command was unacceptable.

<error number>,"<error message>;<annotated SCPI command>"

Example: First set SYST:ERR:VERBOSE ON

If the command SENSE:FREQuently:CENTer 942.6MHz is sent, then sending SYST:ERR? returns:

```
-113,"Undefined header;SENSe:FREQuently:<Err>CENTer 942.6MHz $<NL>"
```

The <Err> shown after FREQuently shows you the spelling error. (The \$<NL> is the typical representation for the command terminator.

If the command SENSE:FREQuency:CENTer 942.6Sec is sent, then sending SYST:ERR? returns:

```
-113,"Invalid suffix;SENSe:FREQuency:CENTer 942.6Sec<Err> $<NL>"
```

The <Err> shown after Sec shows you the invalid suffix.

Factory Preset: Off. This parameter is persistent, which means that it retains the setting previously selected, even through a power cycle.

Remarks: The verbose SCPI error debugging state is global to all the SCPI interfaces.

History: Added version A.04.00

Front Panel

Access: System, Show Errors, Verbose

Exit Main Firmware for Upgrade

:SYSTem:EXIT

Exit the main firmware to allow the firmware to be upgraded.

Example: SYST:EXIT

Front Panel

Access: System, Install, Exit Main Firmware

Host Identification Query

:SYSTem:HID?

Returns a string that contains the host identification. This ID is required in order to obtain the license key that enables a new application (mode) or option.

Example: SYST:HID?

Front Panel

Access: System, Show System

Keyboard Lock

:SYSTem:KLOCK OFF|ON|0|1

:SYSTem:KLOCK?

Disables the instrument keyboard to prevent local input when instrument is controlled remotely. An annunciator reading “Klock” alerts the local user that the keyboard is locked. Or you can display a system message using SYSTem:MESSAge.

Example: SYST:CONF?

History: Added revision A.05.00

License Key for Installing New Applications

:SYSTem:LKEY <'option'>,<'license key'>

:SYSTem:LKEY? <'option'>

Enter the license key required for installing the specified new application (mode) or option. The query returns a string that contains the license key for a specified application or option that is already installed in the instrument. The license key will also be returned if the application is not currently in memory, but had been installed at some previous time.

Option – is a string that is the 3-character designation for the desired option. For example: BAC is the option for cdmaOne.

License key – is a 12 character alphanumeric hexadecimal string given to you with your option.

Example: SYST:LKEY 'BAC','123A456B789C'

Remarks: The license key is unique to the specific option installed in a particular instrument (model number and serial number specific).

Front Panel

Access: System, Install, License Key

Delete a License Key

```
:SYSTem:LKEY:DELeTe <'application option'>,<'license key'>
```

Allows you to delete the license key, for the selected application, from instrument memory.

NOTE

If the license key is deleted, you will be unable to reload or update the application in instrument memory without re-entering the license key. The license key only works with one particular instrument serial number.

<application> - is a string that is the same as one of the enumerated items used in the INSTRument[:SELEct] command.

<license key> - is a 12 character alphanumeric string given to you with your application

Front Panel

Access: None

Remote Message

```
:SYSTem:MESSAge <string>
```

Enables remote user to send message that will appear in the Status Bar at bottom of the instrument display. New message will overwrite any previous message. Message will remain until removed by use of :SYSTem:MESSAge:OFF..

The SYSTem:KLOCK command will lock out the front panel keys.

Example: :SYSTem:MESSAge "Instrument currently in use remotely by Ted in R+D"

Remarks: Message appears as green text against a black background to differentiate it from internally generated messages which appear as white text against a black background.

History: Added revision A.05.00

Remote Message Turned Off

:SYSTem:MESSAge:OFF

Removes any system message from the Status Bar at the bottom of the instrument display. A message can be displayed using the :SYSTem:MESSAge command.

Example: :SYSTem:MESSAge:OFF

History: Added revision A.05.00

Service Password

:SYSTem:PASSword[:CENable]<integer>

Enables access to the service functions by means of the password.

Front Panel

Access: **System, Show System, Service Password**

Preset

:SYSTem:PRESet

Returns the instrument to a set of defined conditions. This command does not change any persistent parameters.

Front Panel

Access: **Preset**

Set Time

:SYSTem:TIME <hour>,<min>,<sec>

:SYSTem:TIME?

Sets the time of the real-time clock of the instrument.

Hour must be an integer from 0 to 23.

Minute must be an integer from 0 to 59.

Second must be an integer from 0 to 59.

Front Panel

Access: **System, Time/Date, Set Time**

Adjust Time

:SYSTem:TIME:ADJust <seconds>

Adjust the instruments internal time by the value entered.

Range: Larger than you should ever need

Example: **SYST:TIME:ADJ 3600** will advance the time one hour.

SYST:TIME:ADJ -86400 will back the date up one day, without changing the time of day (minutes or seconds).

History: In revision A.02.00 and later

Default Unit: seconds

SCPI Version Query

:SYSTem:VERSion?

Returns the SCPI version number with which the instrument complies.

TRIGger Subsystem

The Trigger Subsystem is used to set the controls and parameters associated with triggering the data acquisitions. Other trigger-related commands are found in the INITiate and ABORt subsystems.

The trigger parameters are global within a selected Mode. The commands in the TRIGger subsystem set up the way the triggers function, but selection of the trigger source is made from each measurement. There is a separate trigger source command in the SENSE:<meas> subsystem for each measurement. The equivalent front panel keys for the parameters described in the following commands, can be found under the **Mode Setup, Trigger** key.

Automatic Trigger Control

:TRIGger[:SEQuence]:AUTO:STATE OFF|ON|0|1

:TRIGger[:SEQuence]:AUTO:STATE?

Turns the automatic trigger function on and off. This function causes a trigger to occur if the designated time has elapsed and no trigger occurred. It can be used with unpredictable trigger sources, like external or burst, to make sure a measurement is initiated even if a trigger doesn't occur. Use TRIGger[:SEQuence]:AUTO[:TIME] to set the time limit.

Factory Preset
and *RST Off for cdma2000, W-CDMA, NADC, PDC, 1xEV-DO

Front Panel
Access **Mode Setup, Trigger, Auto Trig**

Automatic Trigger Time

:TRIGger[:SEQuence]:AUTO[:TIME] <time>

:TRIGger[:SEQuence]:AUTO[:TIME]?

After the measurement is activated the instrument will take a data acquisition immediately upon receiving a signal from the selected trigger source. If no trigger signal is received by the end of the time specified in this command, a data acquisition is taken anyway. TRIGger[:SEQuence]:AUTO:STATE must be on.

Factory Preset: 100.0 ms
Range: 1.0 ms to 1000.0 s
 0.0 to 1000.0 s for cdma2000, W-CDMA, 1xEV-DO

Default Unit: seconds

Front Panel

TRIGger Subsystem

Access **Mode Setup, Trigger, Auto Trig**

External Trigger Delay

:TRIGger[:SEquence]:EXTeRnal[1]|2:DELAy <time>

:TRIGger[:SEquence]:EXTeRnal[1]|2:DELAy?

Set the trigger delay when using an external trigger. Set the trigger value to zero (0) seconds to turn off the delay.

EXT or EXT1 is the front panel trigger input.

EXT2 is the rear panel trigger input.

Factory Preset: 0.0 s

Range: -100.0 ms to 500.0 ms

Default Unit: seconds

Front Panel

Access: **Mode Setup, Trigger, Ext Rear (or Ext Front), Delay**

External Trigger Level

:TRIGger[:SEquence]:EXTeRnal[1]|2:LEVel <voltage>

:TRIGger[:SEquence]:EXTeRnal[1]|2:LEVel?

Set the trigger level when using an external trigger input.

EXT or EXT1 is the front panel trigger input

EXT2 is the rear panel trigger input

Factory Preset: 2.0 V

Range: -5.0 to +5.0 V

Default Unit: volts

Front Panel

Access: **Mode Setup, Trigger, Ext Rear (or Ext Front), Level**

External Trigger Slope

:TRIGger[:SEquence]:EXTeRnal[1]|2:SLOPe NEGative|POSitive

:TRIGger[:SEquence]:EXTeRnal[1]|2:SLOPe?

Sets the trigger slope of an external trigger input to either NEGative or POSitive.

EXT or EXT1 is the front panel trigger input.

EXT2 is the rear panel trigger input.

Factory Preset: Positive

Front Panel

Access: **Mode Setup, Trigger, Ext Rear (or Ext Front), Slope**

Frame Trigger Adjust

:TRIGger[:SEquence]:FRAMe:ADJust <time>

Lets you advance the phase of the frame trigger by the specified amount. It does not change the period of the trigger waveform. If the command is sent multiple times, it advances the phase of the frame trigger more each time it is sent.

Factory Preset: 0.0 s

Range: 0.0 to 10.0 s

Default Unit: seconds

Front Panel

Access: None

Frame Trigger Period

:TRIGger[:SEquence]:FRAMe:PERiod <time>

:TRIGger[:SEquence]:FRAMe:PERiod?

Set the frame period that you want when using the external frame timer trigger. If the traffic rate is changed, the value of the frame period is initialized to the preset value.

Factory Preset: 250.0 μ s for Basic, cdmaOne

4.615383 ms, for GSM

26.666667 ms for cdma2000 and 1xEV-DO

10.0 ms (1 radio frame) for W-CDMA

90.0 ms for iDEN (E4406A)

20.0 ms with rate=full for NADC, PDC

40.0 ms with rate=half for NADC, PDC

Range: 0.0 ms to 559.0 ms for Basic, cdmaOne, GSM, cdma2000, W-CDMA, 1xEV-DO

1.0 ms to 559.0 ms for iDEN (E4406A), NADC, PDC

Default Unit: seconds

TRIGger Subsystem

Front Panel

Access: **Mode Setup, Trigger, Frame Timer, Period**

Frame Trigger Sync Source

:TRIGger [:SEquence] :FRAMe:SYNC EXTFront | EXTRear | OFF

:TRIGger [:SEquence] :FRAMe:SYNC?

Selects the input port location for the external frame trigger that you are using.

Factory Preset: Off

Remarks: You must be in the Basic, cdmaOne, EDGE (w/GSM), GSM, iDEN (E4406A), NADC, PDC, Service mode to use this command. Use INSTRument:SElect to set the mode.

Front Panel

Access: **Mode Setup, Trigger, Frame Timer, Sync Source**

History Changed firmware revision A.05.00.

Frame Trigger Synchronization Offset

:TRIGger [:SEquence] :FRAMe:SYNC:OFFSet <time>

:TRIGger [:SEquence] :FRAMe:SYNC:OFFSet?

Lets you adjust the frame triggering with respect to the external trigger input that you are using.

Factory Preset: 0.0 s

Range: 0.0 to 10.0 s

Default Unit: seconds

Remarks: You must be in the Basic, cdmaOne, GSM, EDGE, iDEN (E4406A), NADC, PDC, Service mode to use this command. Use INSTRument:SElect to set the mode.

History: Revision A.03.27 or later

Front Panel

Access: **Mode Setup, Trigger, Frame Timer, Offset**

Trigger Holdoff

:TRIGger [:SEquence] :HOLDoff <time>

:TRIGger [:SEquence] :HOLDoff?

Set a value of the holdoff time between triggers. After a trigger, another trigger will not be allowed until the holdoff time expires. This parameter affects all trigger sources.

Factory Preset: 0.0 s
 20.0 ms for iDEN (E4406A)
 10.0 ms for NADC or PDC

Range: 0.0 to 500.0 ms

Default Unit: seconds

Front Panel
 Access: **Mode Setup, Trigger, Trigger Holdoff**

Video (IF) Trigger Delay

:TRIGger[:SEquence]:IF:DElay <time>

:TRIGger[:SEquence]:IF:DElay?

Set a value of the trigger delay of the IF (video) trigger (signal after the resolution BW filter).

Factory Preset: 0.0 s
 Range: -100.0 ms to 500.0 ms
 Default Unit: seconds

Front Panel
 Access: **Mode Setup, Trigger, Video (IF Envlp), Delay**

Video (IF) Trigger Level

:TRIGger[:SEquence]:IF:LEvel <ampl>

:TRIGger[:SEquence]:IF:LEvel?

Set the trigger level when using the IF (video) trigger.

Factory Preset: -6.0 dBm for cdmaOne, GSM, EDGE, Basic, Service (E4406A), cdma2000, W-CDMA, 1xEV-DO
 -20.0 dBm for iDEN (E4406A)
 -30.0 dBm for NADC, PDC

Range: -200.0 to 50.0 dBm

Default Unit: dBm

Front Panel

TRIGger Subsystem

Access: **Mode Setup, Trigger, Video (IF Envlp), Level**

Video (IF) Trigger Slope

:TRIGger[:SEquence]:IF:SLOPe **NEGative|POSitive**

:TRIGger[:SEquence]:IF:SLOPe?

Sets the trigger slope when using the IF (video) trigger, to either **NEGative** or **POSitive**.

Factory Preset: **Positive**

Front Panel

Access: **Mode Setup, Trigger, Video (IF Envlp), Slope**

RF Burst Trigger Delay

:TRIGger[:SEquence]:RFBurst:DELay **<time>**

:TRIGger[:SEquence]:RFBurst:DELay?

Set the trigger delay when using the RF burst (wideband) trigger.

Factory Preset: **0.0 μ s**

Range: **-100.0 ms to 500.0 ms**

Default Unit: **seconds**

Front Panel

Access: **Mode Setup, Trigger, RF Burst, Delay**

RF Burst Trigger Level

:TRIGger[:SEquence]:RFBurst:LEVel **<rel_power>**

:TRIGger[:SEquence]:RFBurst:LEVel?

Set the trigger level when using the RF Burst (wideband) Trigger. The value is relative to the peak of the signal. RF Burst is also known as RF Envelope.

Factory Preset: **-6.0 dB**

Range: **-25.0 to 0.0 dB**

-200.0 to 0.0 dB for NADC, PDC

Default Unit: **dB**

Front Panel

Access: **Mode Setup, Trigger, RF Burst, Peak Level**

RF Burst Trigger Slope

:TRIGger[:SEquence]:RFBurst:SLOPe NEGative|POSitive

:TRIGger[:SEquence]:RFBurst:SLOPe?

Set the trigger slope when using the RF Burst (wideband) Trigger.

Factory Preset: Positive

Remarks: You must be in the cdmaOne, cdma2000, W-CDMA mode to use this command. Use :INSTrument:SElect to set the mode.

Front Panel

Access: **Mode Setup, Trigger, RF Burst, Slope**



TRIGger Subsystem

- I/Q origin offset
 - phase & frequency error, 448
- Symbols**
- *LRN, 68
- Numerics**
- 10 MHz reference adjustment, 141
- 1xEV-DO
 - terminal modulation accuracy, 131
- 1xEV-DO measurement, 297, 301, 496
- 321.4 MHz reference adjustment, 146
- 50 MHz reference adjustment, 147, 148, 149, 206
- A**
- abort calibration, 137
- abort command, 73
- abort commands, 73
- absolute limit
 - ACP, 323
- ACK channel definition
 - terminal code domain measurement, 548
 - terminal modulation accuracy measurement, 556
- ACK channel power gain
 - terminal modulation accuracy (rho), 130
- ACP
 - absolute limits, 323
 - averaging, 318, 327
 - FFT, 322, 323, 328, 329
 - limit testing, 75, 324
 - offset frequencies, 325, 327
 - offset ref attenuation, 332, 333
 - offset sideband choice, 336, 508
 - offset sweep time, 337, 338, 343
 - relative limits, 324
 - setting amplitude levels, 326
 - testing, 322, 323, 328, 329, 331, 332, 333, 336, 337, 338, 340, 341, 343, 508
 - trigger source, 344
 - view of data, 155
- ACPR
 - amplitude levels, 333, 335
 - averaging, 318, 327
 - detector type, 342
 - FFT sweep, 343
 - offset frequencies, 329
 - resolution bandwidths, 327
 - sweep mode detection, 342
 - sweep time, 342
 - sweep type, 343
 - swept mode res BW, 341, 342
 - testing, 322, 323, 328, 329
 - testing choices, 318, 327, 331, 336, 338, 341, 343, 345, 508
- acquisition packing
 - WAVeform, 566
- active channel threshold value, 350
- active code channel
 - terminal code domain measurement, 548
 - terminal modulation accuracy measurement, 556
- active code domain power tolerance
 - terminal modulation accuracy (rho), 130
- active data channel
 - code domain power, 347
 - RHO, 482
- active license key ID, 594
- active set threshold
 - CDP, 77
 - modulation accuracy (rho), 122
 - TCDP, 86
 - terminal modulation accuracy (rho), 129
- Active Set Threshold level
 - terminal modulation accuracy measurement, 558
- active set threshold mode
 - CDP, 77
 - modulation accuracy (rho), 122
 - TCDP, 86
 - terminal modulation accuracy (rho), 129
- ADC calibration, 137, 138, 142, 143
- ADC dithering
 - SPECTrum, 532
 - WAVeform, 566
- ADC filter
 - WAVeform, 566
- ADC RAM calibration, 138
- ADC range
 - code domain power, 347
 - modulation accuracy (rho), 482
 - QPSK EVM, 408
 - SPECTrum, 533
 - terminal code domain measurement, 549
 - terminal modulation accuracy measurement, 557
 - WAVeform, 567
- adjacent channel power
 - dynamic range, 320
 - fast mode ADC range, 320
 - fast mode relative attenuation, 321
 - root raised cosine filter alpha, 321
 - root raised cosine filter state, 322
- adjacent channel power measurement, 317, 322, 323, 328, 329
- adjacent channel power ratio
 - measurement, 198, 317
 - See also ACPR
- adjust timebase frequency, 296
- adjustment
 - 50 MHz reference, 206
- align
 - now, 72, 138
- align 50 MHz reference, 206
- alignment commands, 137
- alignments
 - time corrections, 149
- amplitude
 - input range, 452
 - maximizing input signal, 452
- application
 - uninstalling, 309
- application installation, 309
- application, deleting, 595
- applications, selecting, 189, 190
- ARFCN setting, 360, 361, 362
- ARIBT53, 481
- ASCII data format, 175
- attenuation
 - setting, 451
- attenuator alignment, 139
- average count
 - intermodulation, 416
 - multi carrier power, 422
 - terminal modulation accuracy measurement, 559
- averaging
 - ACP, 317, 318
 - ACPR, 317, 318
 - CDPower, 349
 - CHPower, 366, 427
 - CSPur, 372, 373, 403, 554
 - EVM, 375, 405
 - modulation accuracy (rho), 484
 - OBW, 426
 - ORFSpectrum, 379, 380, 431, 432
 - output RF spectrum, 379, 380, 431, 432
 - phase & frequency error, 447, 448
 - phase and frequency error measurement, 447
 - power vs. time, 391, 392, 456, 457
 - QPSK EVM, 409, 410
 - SPECTrum, 534, 535
 - traces, 429, 585, 586
 - transmit band spurs, 186, 346, 402, 450, 553, 567
 - transmit power, 562, 563
 - WAVeform, 568, 569

- averaging count
 - spectrum emission mask, 496
- averaging state
 - intermodulation, 416, 422
 - power vs. time, 391, 456
 - spectrum emission mask, 496, 497
 - terminal modulation accuracy measurement, 559, 560
- averaging termination control
 - intermodulation, 417
 - multi carrier power, 422
 - terminal modulation accuracy measurement, 559
- B**
- background alignment, 139
- bandwidth
 - ACPR, 318
 - CHPower, 367
 - occupied bandwidth, 428
 - ORFSpectrum, 380, 382, 384, 432, 433, 435
 - output RF spectrum, 381, 382, 383, 433, 434, 435
 - power vs. time, 392, 458
 - PVTime, 393, 458, 459, 460
 - SPECTrum, 538
 - spectrum emission mask, 497
 - transmit power, 563
 - TXPower, 563
 - WAVEform, 569, 570
- base code length, 155
- base frequencies delta
 - intermodulation, 419
 - multi carrier power, 423
- base frequency auto search
 - intermodulation, 418
- base lower frequency
 - intermodulation, 419
- base station
 - loss correction, 370, 371
- base station testing, 478, 479
 - type, 479
- base transmit station
 - loss correction, 370
- base upper frequency
 - intermodulation, 420
- BER
 - frames, 76
 - limit testing, 76
- binary data order, 175
- bit error rate limits
 - BER, 76
- bit error rate measurement, 207
- BMP screen files, 313
- burst carriers, 477
- burst search threshold, 546
- burst synchronization, 376, 406
 - power vs. time, 393, 459
- burst trigger
 - level, 604
- bus configuration, 591
- byte order of data, 175
- C**
- calibration, 138
 - abort, 137
 - ADC, 137, 138, 142, 143
 - ADC RAM, 138
 - all, 138
 - amount displayed, 140
 - attenuator, 139
 - automatic, 139
 - condition register, 578, 579, 580
 - corrections on/off, 140
 - defaults, 144
 - IEEE command, 67
 - IF flatness, 141
 - image filter, 141
 - internal reference, 141, 146, 147, 148, 149
 - pre-filter, 144, 145
 - query, 67
 - RF gain, 142
 - time corrections, 149
 - trigger delay, 150
 - trigger interpolation, 150
- calibration commands, 137
- calibration condition register, 579
- carrier
 - type, 477
- carrier selection, 477
- CCDF measurement, 265
- CDMA
 - PN offset number, 363
- CDMA installation, 309
- CDMA measurement, 225, 226, 317, 347, 366, 372, 482
- CDMA standards, 481
- cdma2000
 - ACP measurement, 326, 331, 340, 341
 - averaging, 409, 410
 - offset frequencies, 501, 516, 517, 528
 - offset frequencies auto mode, 502, 503, 518
 - spectrum emission mask measurement, 509, 510, 512, 513, 514, 515, 523, 524, 525, 526, 527, 528
 - trigger source, 357, 413, 492, 493, 531
- cdma2000 measurement, 198, 246, 249, 254, 265, 271, 286, 317, 408, 416, 426, 454, 496
- cdmaOne
 - ACP measurement, 326, 331, 338, 340, 341
 - trigger source, 357, 492, 493
- cdmaOne measurement, 198, 209, 259, 271
- CDP
 - active set threshold, 77
 - active set threshold mode, 77
 - base code length, 155
 - composite symbol boundary, 79
 - computation type, 84
 - data bit format, 78
 - data bit format threshold, 78
 - data channel type, 84
 - decode axis, 77
 - display spread code, 80
 - measurement channel type, 78
 - spread code, 80, 81, 358
 - sweep offset, 81
 - sweep time, 82
 - time offset detection, 83
 - time offset for DPCH, 83
 - Walsh code base length, 84
 - Walsh code length, 85
 - Walsh code length total power, 80
 - Walsh code number, 85
 - Walsh code order, 85
- CDPower
 - active set threshold value, 350
 - chip rate, 351
 - data capture time, 350
 - long code mask, 356
 - measurement method, 351
 - Phase compensation by pilot, 351
 - QOF, 353
 - quasi-orthogonal function, 353
 - scramble code, 357
 - scramble code down link, 357
 - scramble code offset, 357
 - scramble code up link, 358
 - selecting spectrum type, 355
 - selecting symbol boundary, 354
 - sweep time, 355
 - symbol rate, 359
 - trigger source, 359
 - view of data, 156
- center frequency setting, 415
- center frequency step size, 415
- changing
 - instrument settings, 317
 - mass storage location, 311
- channel burst type, 363
- channel number

- ARFCN, 360, 361, 362
 - channel power measurement
 - See also CHPower
 - channel power measurement, 225, 366
 - chip rate
 - CDPower, 351
 - modulation accuracy (rho), 485
 - power control, 443
 - power vs. time, 460
 - QPSK EVM, 411
 - terminal code domain measurement, 551
 - terminal modulation accuracy measurement, 560
 - CHPower
 - number of points, 368
 - sweep time, 368, 369
 - trigger source, 369
 - CKOR, 481
 - clear status, IEEE command, 67
 - close spurs measurement, 226, 372
 - See also CSPur
 - code domain error limit
 - modulation accuracy (rho) (BTS), 123
 - terminal modulation accuracy (rho), 130
 - code domain error limit (BTS)
 - cdma2000, 123
 - W-CDMA (3GPP), 123
 - code domain power
 - active data channel, 347
 - ADC range, 347
 - demod alpha, 348
 - code domain power measurement, 209, 259, 347
 - See also CDPower
 - code domain power measurement method, 351
 - color printing, 178
 - command complete, 69
 - commands
 - CONFigure, 196
 - FETCh, 196
 - MEASure, 195
 - READ, 197
 - CONFigure command use, 193
 - CONFigure commands, 196
 - constellation type
 - QPSK EVM, 410
 - continuous carriers, 477
 - continuous vs. single measurement mode, 183
 - control measurement commands, 183
 - correction
 - base station loss, 370, 371
 - base transmit station loss, 370
 - mobile station loss, 370
 - correction constant default, 144
 - correction constants on/off, 140
 - corrections
 - time, 149
 - CPICH power measurement
 - modulation accuracy (rho), 485
 - current measurement, 151
 - curve fit the data, 89, 99
 - custom printer, 177, 178
 - D**
 - data
 - querying, 89, 99
 - data capture length
 - power control, 442
 - data capture time
 - CDPower, 350
 - terminal code domain measurement, 550
 - data channel definition
 - terminal code domain measurement, 548
 - terminal modulation accuracy measurement, 556
 - data channel power gain
 - terminal modulation accuracy (rho), 130
 - data decimation, 539
 - WAVeform, 571
 - data format, 175
 - data from measurements, 193
 - date, setting, 592
 - DCS1800, 480
 - debugging errors in programs, 593
 - decimation
 - SPECTrum, 539
 - decimation of data
 - WAVeform, 571
 - default values, setting remotely, 196
 - defaults
 - for persistent functions, 592
 - delete the mode/application, 309
 - delta markers, 109
 - demod alpha
 - code domain power, 348
 - modulation accuracy (rho), 483
 - QPSK EVM, 409
 - diagnostic commands, 137, 153
 - disk
 - selecting, 311
 - disk drive commands, 311
 - display
 - on/off, 157
 - PVT limits, 157, 159
 - saving to a file, 180
 - spectrum window, 161, 162, 168, 169
 - tiling, 158
 - trace, 163
 - window focus move control, 170
 - window tile, 158
 - x-axis couple control, 170
 - x-axis reference level, 171
 - x-axis reference position, 171
 - x-axis scale/div, 170
 - y-axis couple control, 171
 - y-axis reference level, 172
 - y-axis reverence position, 172
 - y-axis scale/div, 172
 - zoom, 158
- display ACP data, 155
- display code domain data, 156
- display commands, 155
- display EVM data, 157
- display PVT data, 159
- display rho data, 160
- displays
 - storing, 312, 313
- displays, no. per page, 180
- dithering of ADC
 - WAVeform, 566
- dithering the ADC, 532
- DJSMR, 479
- domain name, 591
- DRC channel definition
 - terminal code domain measurement, 549
 - terminal modulation accuracy measurement, 557
- DRC channel power gain
 - terminal modulation accuracy (rho), 131
- Droop Error, EDGE EVM, 228
- dynamic range
 - adjacent channel power, 320
- E**
- EDGE EVM,Droop Error, 228
- EDGE transmit band spurs measurement, 402
- EGSM
 - RGSM
 - DCS, 480
- error information, during execution, 593
- error monitoring, 71, 575
- error vector magnitude measurement, 227, 239, 375, 405
- error vector measurement
 - See also EVM
- errors, querying, 592
- even second synchronization, 545

- event status byte, enable and read, 67
- event status enable, IEEE command, 67
- event status register
 - query and clear, 68
- EVM
 - averaging, 375, 405
 - burst synchronization, 376, 406
 - limit testing, 102, 103
 - points per symbol, 406
 - symbol dots, 376, 377
 - sync word, 103
 - trigger source, 378, 406
 - view of data, 157
- external reference, 495
- external trigger
 - delay, 600
 - level, 600
 - slope, 600
- F**
- factory default for persistent functions, 592
- factory defaults, 144
- fast mode ADC range
 - adjacent channel power, 320
- fast mode relative attenuation
 - adjacent channel power, 321
- FETCh command use, 193
- FETCh commands, 196
- FFT
 - SPECTrum, 539, 540, 541
- FFT bandwidth, SPECTrum, 536, 537
- FFT window
 - occupied bandwidth, 428
- file type, screen, 313
- filter alpha
 - power vs. time, 461
- filter calibration, 144, 145
- filter control
 - power vs. time, 461
- finding programming errors in execution, 593
- firmware upgrading, 593
- flatness calibration of IF, 141
- form feed printer, 179
- format, data, 175
- format, setting spread rate, 479
- frame trigger adjustment, 601, 602
- frame trigger period, 601
- frame trigger sync mode, 602
- frames
 - BER, 76
- frequencies offset
 - ACP, 325, 327
- frequency
 - carrier setting, 477
 - center, 415
 - step size, 415
- frequency band limits
 - OBW, 116
- frequency condition register, 580, 581
- frequency error limit test
 - RHO, 124, 125
- frequency offsets
 - ORFSpectrum, 384, 386, 436
 - output RF spectrum, 437
- frequency span
 - CHPower, 367
 - SPECTrum, 542
 - spectrum emission mask, 499
- front panel, lock-out, 594
- G**
- GIF screen files, 313
- GPIB address, 591
- GSM installation, 309
- GSM measurement, 385, 387, 391, 436, 439, 455, 562
- GSM450, 480
- GSM480, 480
- GSM850, 480
- H**
- hardcopy output, 177
- hardware status, 575
- hardware status commands, 153
- hopping carriers, 477
- host identification query, 594
- HP-IB. *See* GPIB
- I**
- I long code mask
 - terminal code domain measurement, 552
 - terminal modulation accuracy measurement, 560
- I/Q data results, 293, 307
- I/Q marker query, 134, 136
- iDEN
 - ACP measurement, 326, 331, 340, 341
 - trigger source, 430
- iDEN averaging, 405
- iDEN limit testing, 324
- iDEN measurement, 207, 254, 426
- iDEN offset frequencies, 325, 327
- iDEN trigger source, 344, 406
- identity, IEEE command
 - options, query
 - model number, query, 68
- IEEE command, 68
- IEEE command, event status enable, 67
- IEEE common commands
 - *commands, IEEE, 67
- IF flatness adjustment, 141
- IF trigger delay, 603
- IF trigger level, 603
- IF trigger slope, 604
- image filter calibration, 141
- initiate measurement, 71, 183, 184
- input attenuation, 451
- input configuration, 185
- input port selection, 414
- input power
 - maximum, 452
 - range, 452
- inputs
 - configuration, 591
- install application, 309, 594
- instrument
 - memory functions, 309
- instrument configuration, 189
- instrument memory, 311
- instrument preset, 70, 596
- instrument status, 575
 - monitoring, 71
 - monitoring status monitoring, 71
- integration bandwidth
 - intermodulation, 417
- integrity condition register, 582, 583
- integrity signal condition register, 583, 584
- intermodulation
 - average count, 416
 - averaging state, 416, 422
 - averaging termination control, 417
 - base frequencies delta, 419
 - base frequency auto search, 418
 - base lower frequency, 419
 - base upper frequency, 420
 - integration bandwidth, 417
 - measurement mode, 420
 - measurement reference, 421, 426
 - resolution bandwidth, 417
 - resolution bandwidth state, 418
 - root raised cosine filter alpha, 418
 - root raised cosine filter state, 418
 - span, 420
- intermodulation measurement, 249, 416
 - See also* IM
- internal reference, 495
- internal reference selection, 414
- internet protocol address, 591
- invert display printout, 181
- invert screen background, 313
- IP address, 591

- IP, instrument preset, 596
- IQ port selection, 414
- IS-95A, 481
- IS-95B, 481
- IS-95C, 481
- J**
- JSTD8, 481
- K**
- keyboard lock-out, 594
- L**
- LAN
 - IP address, 591
- landscape printing, 179
- length
 - QPSK EVM, 412
- license key, 594, 595
- license key ID, 594
- limit line testing, 89
- limit testing
 - ACP, 75, 323, 324
 - BER, 76
 - cdmaOne, 124
 - EVM, 102, 103, 124
 - NADC, 75, 102, 103
 - OBW, 116
 - PDC, 75, 102, 103
 - RHO, 124
 - TSPur, 101, 135
- loading
 - modes/application, 309
- lock-out
 - front panel, 594
- long code mask
 - CDPower, 356
 - modulation accuracy (rho), 491
- M**
- M16QAM, 479
- M64QAM, 479
- making measurements, 193
- marker
 - I/Q query, 134, 136
- markers, 105
 - assigning them to traces, 110
 - maximum, 108
 - minimum, 109
 - off, 109
 - trace assignment, 114
 - turn off, 108
 - type, 109
 - valid measurement, 105
 - value, 115
 - value of, 108
 - x-axis location, 114
 - y-axis, 115
- masks
 - power vs. time, 393, 394, 395, 396, 397, 399, 461, 462, 463, 464, 465, 466, 467, 468, 469, 470, 471, 472, 473, 474
- mass storage
 - selecting, 311
- mass storage commands, 311
- maximum value of trace data, 89, 99
- mean value of trace data, 89, 99
- MEASure command use, 193
- MEASure commands, 195
- measurement
 - adjacent channel power, 317
 - adjacent channel power ratio, 317
 - channel power, 366
 - close spurs, 372
 - code domain power, 347
 - error vector magnitude, 375, 405
 - intermodulation, 416
 - markers, 105
 - modulation accuracy (rho), 482
 - multi carrier power measurement, 422
 - occupied BW, 426
 - output RF spectrum, 379, 430
 - phase and frequency error, 447
 - power statistics CCDF measurement, 454
 - power vs. time, 391, 455
 - QPSK error vector magnitude, 408
 - query current, 151
 - spectrum (frequency domain), 532
 - spectrum emission mask, 496
 - spurious emissions and ACP, 496
 - transmit band spurs, 402, 553
 - transmit power, 562
 - waveform (time domain), 566
- measurement channel type
 - CDP, 78
 - RHO, 128
- measurement data type
 - power control, 443
 - RHO, 128
- measurement delay
 - power control, 119
- measurement interval
 - power control, 118, 119
- measurement method
 - output RF spectrum, 388, 439
- measurement mode
 - intermodulation, 420
- measurement modes
 - selecting, 189, 190
- measurement offset
 - power control, 118
 - QPSK EVM, 412
- measurement reference
 - intermodulation, 421, 426
- measurement type
 - power control, 445, 446
 - transmit band spurs, 403, 554
- measurements
 - adjacent channel power ratio, 198
 - bit error rate, 207
 - CCDF, 265
 - channel power, 225
 - close spurs, 226
 - code domain power, 209, 259
 - CONF/FETC/MEAS/READ commands, 193
 - control of, 183
 - error vector magnitude, 227, 239
 - getting results, 193
 - intermodulation, 249
 - modulation accuracy, 271
 - modulation accuracy, terminal, 301
 - multi carrier power, 252
 - occupied BW, 254
 - output RF spectrum, 230, 256
 - phase and frequency error, 262
 - power stat, 265
 - power vs. time, 233, 267
 - QPSK error vector magnitude, 246
 - setting default values remotely, 196
 - single/continuous, 183
 - spectrum (frequency domain), 293
 - spectrum emission mask, 286
 - terminal code domain power, 297
 - transmit band spurs, 237, 304
 - transmit power, 305
 - waveform (time domain), 307
- measuring I/Q data, 293, 307
- memory available, 311
- memory commands, 311
- memory, instrument commands, 309
- message
 - to other users, 595, 596
- micro base station, 479
- minimum value of trace data, 89, 99
- mobile station
 - loss correction, 370
- mobile station testing, 478, 479
- mode, deleting, 595
- modulation accuracy (rho)
 - active set threshold, 122
 - active set threshold mode, 122
 - long code mask, 491
 - phase error limit, 126
 - pilot time offset limit, 126
 - rho result I/Q offset, 122
 - scramble code down link, 491

- scramble code offset, 492
 - scramble code up link, 492
 - sync type, 490, 491
 - time offset limit, 127
 - modulation accuracy (rho) (BTS)
 - code domain error limit (BTS), 123
 - peak EVM limit, 125
 - rho limit, 126
 - RMS EVM limit, 127
 - modulation accuracy (rho) (MS), 125
 - modulation accuracy (rho)
 - measurement, 482
 - See also RHO
 - modulation accuracy measurement, 271
 - monitoring errors, 71
 - monitoring instrument status, 575
 - monitoring status, 71
 - multi carrier estimator
 - modulation accuracy (rho), 485
 - multi carrier power, 422
 - average count, 422
 - averaging termination control, 422
 - base frequencies delta, 423
 - offset frequency absolute limit, 424
 - offset frequency test mode, 425
 - offset select, 425
 - root raised cosine filter alpha, 423
 - root raised cosine filter state, 423
 - multi carrier power measurement, 252, 422
 - See also MCPower
 - multiple users, system message to, 595, 596
- N**
- NADC
 - averaging, 405
 - burst power threshold, 547
 - limit testing, 323, 324
 - offset frequencies, 325, 327
 - trigger source, 344, 406
 - NADC measurement, 239, 317, 405
 - node name, 591
 - normal marker, 109
- O**
- OBW
 - limit testing, 116
 - percent power, 429
 - trigger source, 430
 - OBW averaging, 426
 - occupied bandwidth
 - FFT window, 428
 - occupied BW measurement, 254, 426
 - See also OBW
 - offset for pseudo-random noise, 79, 127
 - offset frequencies, 338
 - ACP, 325, 327
 - spectrum emission mask, 501, 516, 517, 528
 - offset frequencies auto mode
 - spectrum emission mask, 502, 503, 518
 - offset frequency
 - output RF spectrum, 388, 440
 - offset frequency absolute limit
 - multi carrier power, 424
 - offset frequency test mode
 - multi carrier power, 425
 - offset select
 - multi carrier power, 425
 - operation complete, IEEE command, 69
 - operation condition register, 575, 576
 - operation status, 575
 - options
 - query, 70
 - options, IEEE command, 70
 - ORFSpectrum
 - bandwidth, 384, 435, 438
 - bandwidth, 386
 - l offset
 - output RF spectrum measurement, 385, 387, 436, 439
 - measurement type, 389, 441
 - offsets, 384, 386, 387, 388, 436, 438, 439
 - other users
 - system message to, 595, 596
 - other users, lock-out the keys, 594
 - output RF spectrum
 - resolution bandwidth for switching transients at close offsets, 382, 434
 - trigger source, 389, 440
 - output RF spectrum - averaging
 - control, 380, 432
 - output RF spectrum - number of bursts averaged, 379, 431
 - output RF spectrum - offset frequency, 388, 440
 - output RF spectrum - offset frequency list, 437
 - output RF spectrum - resolution
 - bandwidth for switching transients at far offsets, 383, 434, 435
 - output RF spectrum - resolution BW for modulation at close offsets, 381, 433
 - output RF spectrum - resolution BW for modulation at far offsets, 381, 433
 - output RF spectrum measurement, 230, 256, 379, 430
 - See also ORFSpectrum
 - See also orfspectrum
 - output RF spectrum measurement method, 388, 439
 - outputs
 - configuration, 591
- P**
- packing
 - SPECTrum, 532
 - page orientation, 179
 - pass/fail test, 89
 - password for service, 596
 - PCG(slot) length
 - power control, 119
 - PCS, 480
 - PCS1900, 480
 - PDC
 - averaging, 405
 - burst power threshold, 547
 - limit testing, 323, 324
 - offset frequencies, 325, 327
 - trigger source, 344, 406, 430
 - PDC measurement, 239, 254, 317, 405, 426
 - peak EVM limit
 - cdma2000 (BTS), 125
 - modulation accuracy (rho) (BTS), 125
 - modulation accuracy (rho) (MS), 125
 - terminal modulation accuracy (rho), 132
 - W-CDMA (3GPP) (BTS), 125
 - W-CDMA (3GPP) (MS), 125
 - percent power, OBW, 429
 - persistent function defaults, 592
 - personalities
 - selecting, 189, 190
 - PGSM, 480
 - Phase & frequency error
 - I/Q origin offset, 448
 - phase & frequency error - averaging mode, 447
 - phase & frequency error - averaging state, 447
 - phase & frequency error - averaging type, 448
 - phase & frequency error - burst synchronization, 448
 - phase & frequency error - number of bursts averaged, 447
 - phase & frequency error - trace data, 449
 - phase & frequency error - trigger source, 449

- phase and frequency error
 - measurement, [262](#), [447](#)
 - See also PFERror
- Phase compensation by pilot
 - CDPower, [351](#)
- phase error limit
 - cdma2000, [126](#)
 - modulation accuracy (rho), [126](#)
- phase inversion, [355](#)
- pico base station, [479](#)
- Pilot channel definition
 - terminal code domain measurement, [549](#)
 - terminal modulation accuracy measurement, [557](#)
- pilot time offset limit
 - modulation accuracy (rho), [126](#)
 - terminal modulation accuracy (rho), [132](#)
- PKOR, [481](#)
- PN offset
 - CDPower, [352](#)
 - modulation accuracy (rho), [486](#)
- PN offset number setting, [363](#)
- points per symbol
 - EVM, [406](#)
- points/measurement
 - CHPower, [368](#)
- portrait printing, [179](#)
- power
 - % occupied power bandwidth, [429](#)
 - power condition register, [586](#), [587](#), [588](#)
 - power control, [118](#), [442](#)
 - power control chip rate, [443](#)
 - power control data capture length, [442](#)
 - power control measurement data type, [443](#)
 - power control measurement delay, [119](#)
 - power control measurement interval, [118](#), [119](#)
 - power control measurement offset, [118](#)
 - power control measurement type, [445](#), [446](#)
 - power control PCG(slot) length, [119](#)
 - power control PRACH message length, [118](#)
 - power control PRACH preamble length, [119](#)
 - power control PRACH preamble signature, [444](#)
 - power control PRACH preamble signature detection, [444](#)
 - power control RBW filter type, [442](#)
 - power control resolution bandwidth, [442](#)
 - power control root raised cosine alpha, [443](#)
 - power control root raised cosine control, [443](#)
 - power control slot format for MS, [444](#)
 - power control slot offset timing, [120](#)
 - power control uplink scramble code, [445](#)
 - power statistic CCDF
 - cdma2000, [121](#)
 - store reference, [121](#)
 - W-CDMA (3GPP), [121](#)
 - power statistics CCDF measurement, [454](#)
 - See also PStat
 - power threshold setting, [546](#)
 - power vs. time
 - averaging state, [391](#), [456](#)
 - power vs. time - averaging mode, [391](#), [457](#)
 - power vs. time - averaging type, [392](#), [457](#)
 - power vs. time - burst synchronization source, [393](#), [459](#)
 - power vs. time - chip rate, [460](#)
 - power vs. time - custom limit masks, [396](#), [473](#)
 - power vs. time - limit line mask display, [393](#), [461](#)
 - power vs. time - lower mask absolute amplitude levels, [394](#), [464](#)
 - power vs. time - lower mask points, [394](#), [464](#)
 - power vs. time - lower mask relative amplitude levels, [395](#), [465](#)
 - power vs. time - lower mask time points, [395](#), [466](#)
 - power vs. time - mask interval, [467](#)
 - power vs. time - mask offset, [467](#)
 - power vs. time - mask power reference, [466](#)
 - power vs. time - number of bursts averaged, [391](#), [456](#)
 - power vs. time - number of data acquisitions averaged, [456](#)
 - power vs. time - resolution bandwidth, [392](#), [458](#)
 - power vs. time - root raised cosine filter alpha, [461](#)
 - power vs. time - root raised cosine filter control, [461](#)
 - power vs. time - trigger source, [400](#), [475](#)
 - power vs. time - upper mask absolute amplitude levels, [396](#), [467](#), [468](#), [469](#)
 - power vs. time - upper mask points, [397](#), [469](#)
 - power vs. time - upper mask relative amplitude levels, [397](#), [462](#), [463](#), [465](#), [470](#), [471](#), [472](#), [473](#), [474](#)
 - power vs. time - upper mask time points, [399](#), [472](#)
 - power vs. time measurement, [233](#), [267](#), [391](#), [455](#)
 - See also PVTime
- PRACH message length
 - power control, [118](#)
- PRACH preamble length
 - power control, [119](#)
- PRACH preamble signature
 - power control, [444](#)
- PRACH preamble signature detection
 - power control, [444](#)
 - RHO, [486](#)
- pre-ADC bandpass filter
 - SPECTrum, [536](#)
- preamble auto detection
 - CDPower, [353](#)
 - RHO, [487](#)
- preamble length
 - CDPower, [353](#)
 - RHO, [487](#)
- pre-amplifier
 - attenuator, [451](#)
 - on/off, [451](#)
- pre-FFT bandwidth, SPECTrum, [536](#), [537](#)
- preset, [70](#), [596](#)
 - status registers, [576](#)
- print now, [179](#), [181](#)
- print the image again, [180](#)
- printer
 - color capability, [177](#)
 - invert image, [181](#)
 - language selection, [178](#)
 - type selection, [178](#)
- printing, [177](#)
 - color, [178](#)
 - form feed, [179](#)
 - page orientation, [179](#)
 - prints per page, [180](#)
 - reprint, [180](#)
- programming errors, debug
 - information, [593](#)
- pseudo-random noise offset, [79](#), [127](#)
- PVT
 - view of data, [159](#)
- PVT limits display, [157](#), [159](#)
- PVTime
 - bandwidth, [393](#), [458](#), [459](#), [460](#)
 - sweep time, [400](#), [475](#), [564](#)

Q

Q long code mask
terminal code domain measurement,
552
terminal modulation accuracy
measurement, 561

QOF

CDPower, 353

QPSK error vector magnitude
measurement, 246, 408

QPSK error vector measurement
See also EVMQpsk

QPSK EVM

ADC range, 408

averaging, 409, 410

chip rate, 411

constellation type, 410

demod alpha, 409

length, 412

measurement offset, 412

RF carrier mode, 411

spectrum normal/invert, 412

trigger source, 413

QPSKEVM

frequency error limit, 104

IQ offset include, 104

RMS EVM limit, 104

view selection, 158

quasi-orthogonal function

CDPower, 353

query data, 89, 99

questionable condition register, 577,
578

quit command, 73

R

radio format setting, 479

RBW filter type

power control, 442

READ command use, 193

READ commands, 197

real number data format, 175

rear panel external trigger

delay, 600

slope, 600

recall, IEEE command, 70

reference

external, 495

internal, 495

reference adjustment, 141, 146, 147,
148, 149

reference channel resolution bandwidth

spectrum emission mask, 498

reference channel resolution bandwidth
auto mode

spectrum emission mask, 498

reference channel step frequency

spectrum emission mask, 500

reference channel step frequency auto
mode list

spectrum emission mask, 500

reference, selecting internal, 414

register

calibration condition, 579

frequency condition, 580, 581

integrity condition, 582, 583

integrity signal condition, 583, 584

operation condition, 575, 576

power condition, 586, 587, 588

questionable condition, 577, 578

temperature condition, 588, 589

registers

calibration condition, 578, 579, 580

relative limit

ACP, 324

remove the mode, 309

reprint, 180

reset persistent functions, 592

reset, IEEE command, 70

resolution bandwidth

intermodulation, 417

power control, 442

resolution bandwidth state

intermodulation, 418

restart measurement, 184

return data, 89, 99

RF carrier mode

QPSK EVM, 411

RF gain calibration, 142

RF input port gain setting when
pre-amplifier is on, 451

RF input port power gain, 451

RF input, selection, 414

RHO

active data channel, 482

CPICH error limit (BTS), 123

CPICH reference power (BTS), 123

frequency error limit test, 124, 125,
131

limit testing, 124

measurement channel type, 128

measurement data type, 128

SCH sweep time, 490

selecting symbol boundary, 488

spectrum type, 489

spread code, 493

sweep time, 489

symbol rate, 493

view of data, 160

rho limit

cdma2000 (BTS), 126

modulation accuracy (rho) (BTS),
126

terminal modulation accuracy (rho),
132

W-CDMA (3GPP) (BTS), 126

rho overall preamble included

RHO, 487

rho result I/Q offset

modulation accuracy (rho), 122

terminal modulation accuracy (rho),
129

RMS EVM limit

cdma2000 (BTS), 127

modulation accuracy (rho) (BTS),
127

terminal modulation accuracy (rho),
132

W-CDMA (3GPP) (BTS), 127

RMS of trace data, 89, 99

root raised cosine alpha

power control, 443

root raised cosine control

power control, 443

root raised cosine filter alpha

adjacent channel power, 321

intermodulation, 418

multi carrier power, 423

root raised cosine filter state

adjacent channel power, 322

intermodulation, 418

multi carrier power, 423

RRI limit

1xEV-DO, 133

terminal modulation accuracy (rho),
133

S

sampling trace data, 89, 99

save, IEEE command, 71

saving a display, 180

saving screens, 312, 313

SCH included in RHO, 490

SCPI

version of, 597

SCPI errors during execution, 593

scramble code

CDPower, 357

scramble code down link

CDPower, 357

modulation accuracy (rho), 491

scramble code for uplink

power control, 445

scramble code offset

CDPower, 357

modulation accuracy (rho), 492

scramble code up link

CDPower, 358

modulation accuracy (rho), 492

screen

- saving to a file, 180
 - screen background invert, 313
 - screen file type, 313
 - screens
 - storing, 312, 313
 - select the ARFCN - absolute RF channel number, 360
 - select view
 - terminal modulation accuracy measurement, 168
 - selecting channel, 363
 - self-test, 72
 - sensors, temperature, 292
 - serial number, query, 68
 - service commands, 153
 - service password, 596
 - service request, IEEE command, 71
 - single vs. continuous measurement mode, 183
 - slot format (MS)
 - RHO, 489
 - slot format for MS
 - power control, 444
 - slot offset timing
 - power control, 120
 - slots, setting, 400, 475, 564
 - span
 - CHPower, 367
 - intermodulation, 420
 - SPECTrum, 542
 - SPECTrum
 - acquisition packing, 532
 - ADC range, 533
 - data decimation, 539
 - FFT length, 539, 540
 - FFT resolution BW, 540
 - FFT window, 541
 - FFT window delay, 541
 - frequency span, 542
 - sweep time, 543
 - trigger source, 544
 - spectrum (frequency domain)
 - measurement, 293, 532
 - See also SPECTrum
 - spectrum emission mask
 - detector mode, 499
 - measurement interval, 530
 - offset frequencies, 501, 517
 - offset start frequency, 504, 519
 - offset stop frequency, 505, 506, 520, 521
 - offset stop frequency auto mode, 505, 520
 - power reference, 531
 - relative attenuation, 507, 522
 - setting amplitude levels, 509, 510, 512, 513, 514, 515, 523, 524, 525, 526, 527, 528
 - testing choices, 511, 525
 - trigger source, 531
 - spectrum emission mask measurement, 286, 496
 - See also SEM
 - spectrum emission mask
 - offset frequencies auto mode, 502, 503, 518
 - spectrum measurement display, 161, 162, 168, 169
 - spectrum measurement, IF flatness, 141
 - spectrum normal/invert
 - QPSK EVM, 412
 - terminal code domain measurement, 551
 - terminal modulation accuracy measurement, 560
 - spectrum phase
 - CDPower, 355
 - spectrum segment
 - spectrum emission mask, 529, 530
 - spectrum type
 - RHO, 489
 - spread rate setting, 479
 - spurious emissions and ACP measurement, 496
 - SRQ, 71
 - standard deviation of trace data, 89, 99
 - standard event status byte, enable and read, 67
 - standard event status register, IEEE command, 68
 - standard, selecting for CDMA, 481
 - standard, selecting for GSM, 480
 - start measurement, 71, 183, 184
 - state
 - changing, 317
 - get data, 68
 - recalling, 70
 - saving, 71
 - status
 - preset, 576
 - temperature measurement, 292
 - status byte
 - clearing, 67
 - status byte, IEEE command, 71
 - status subsystem, 575
 - stop command, 73
 - stop other local users, 594
 - store reference
 - power statistic CCDF, 121
 - storing
 - screens, 312, 313
 - sweep time
 - CDPower, 355
 - PVTime, 400, 475, 564
 - RHO, 489
 - SPECTrum, 543
 - WAVEform, 572
 - switching transients
 - ORFSpectrum, 386, 387, 438
 - symbol boundary
 - CDPower, 354
 - symbol dots
 - EVM, 376, 377
 - symbol rate
 - CDPower, 359
 - RHO, 493
 - symbol, points per, 406
 - sync alignment, 545
 - sync burst RF amplitude delay, 546
 - sync type
 - CDPower, 355, 356
 - modulation accuracy (rho), 490, 491
 - sync word
 - NADC/PDC, 103
 - synch channel sweep time, 490
 - synchronization, 69, 72, 546
 - CDMA, 545
 - EVM, 376, 406
 - GSM, 545, 546
 - NADC, 547
 - PDC, 547
 - phase & frequency error, 448
 - power vs. time, 393, 459
 - system configuration, 591
 - system gain calibration, 142
 - system message, 595, 596
- ## T
- TCDP
 - active set threshold, 86
 - active set threshold mode, 86
 - computation type, 87
 - decode axis, 86
 - sweep time, 87
 - Walsh code length, 88
 - Walsh code number, 88
 - Walsh code order, 88
 - TCDPower
 - view of data, 163
 - temperature condition register, 588, 589
 - temperature sensor measurement, 292
 - terminal code domain error limit
 - 1xEV-DO, 130
 - Terminal code domain measurement, 548
 - terminal code domain measurement
 - ACK channel definition, 548

- active code channel, 548
 - ADC range, 549
 - chip rate, 551
 - data capture time, 550
 - data channel definition, 548
 - DRC channel definition, 549
 - I long code mask, 552
 - Pilot channel definition, 549
 - Q long code mask, 552
 - spectrum normal/invert, 551
 - trigger source, 551
 - terminal code domain power measurement, 297
 - terminal modulation accuracy frequency error limit test, 131
 - terminal modulation accuracy (rho) ACK channel power gain, 130 active code domain power tolerance, 130 active set threshold, 129 active set threshold mode, 129 code domain error limit, 130 data channel power gain, 130 DRC channel power gain, 131 inactive channel power limit, 131 peak EVM limit, 132 pilot time offset limit, 132 rho limit, 132 rho result I/Q offset, 129 RMS EVM limit, 132 RRI limit, 133
 - Terminal modulation accuracy measurement, 556
 - terminal modulation accuracy measurement, 301 ACK channel definition, 556 active code channel, 556 Active Set Threshold level, 558 ADC range, 557 average count, 559 averaging state, 559, 560 averaging termination control, 559 chip rate, 560 data channel definition, 556 DRC channel definition, 557 I long code mask, 560 Pilot channel definition, 557 Q long code mask, 561 select view, 168 spectrum normal/invert, 560 trigger source, 561
 - test limit BER, 76 OBW, 116
 - test limits, 89 cdmaOne, 124 EVM, 124 NADC, 75, 102, 103 PDC, 75, 102, 103 test, IEEE command, 72 threshold value, CDPower, 350
 - tile the display, 158
 - time setting, 596, 597
 - time corrections, 149
 - time domain measurement, 307, 566
 - time offset limit cdma2000, 127 modulation accuracy (rho), 127
 - time slot auto, 364
 - time slot number, 363
 - timebase frequency accuracy measurement, 296
 - timing control, 69, 72
 - trace averaging, 429, 585, 586
 - trace data phase and frequency error measurement, 449 processing, 89, 99
 - trace display, 163
 - trace format, 175
 - trace names for markers, 110
 - training sequence code (TSC), 364
 - training sequence code (TSC) auto, 365
 - training sequence code channel, 363
 - training sequence code selection, 364, 365
 - transmit band spurs limit testing, 101, 135
 - transmit band spurs - average count, 402, 553
 - transmit band spurs - averaging state, 186, 346, 402, 450, 553, 567
 - transmit band spurs - averaging termination control, 402, 553
 - transmit band spurs - type, 403, 554
 - transmit band spurs measurement, 237, 304, 553
 - transmit power resolution bandwidth, 563
 - transmit power - averaging mode, 562
 - transmit power - averaging state, 562
 - transmit power - averaging type, 563
 - transmit power - number of bursts averaged, 562
 - transmit power measurement, 305, 562
 - See also TXPower
 - trigger auto time, 599 burst level, 604 commands, 599 delay, 600 delay, IF, 603 external, 600 frame adjustment, 601, 602 frame period, 601 frame sync mode, 602 holdoff, 602 level, 600 level, IF, 603 on/off, 599 output RF spectrum, 389, 440 phase & frequency error, 449 power vs. time, 400, 475 slope, 600 slope, IF, 604 SPECTrum, 544 timeout, 599 TXPower, 565 WAVEform, 572
 - trigger delay alignment, 150
 - trigger interpolation alignment, 150
 - trigger measurement, 183, 184
 - trigger source ACP, 344 cdma2000, 359 EVM, 378, 406 OBW, 430 QPSK EVM, 413 Rho, 357, 492, 493 spectrum emission mask, 531 terminal code domain measurement, 551 terminal modulation accuracy measurement, 561 W-CDMA, 359
 - trigger, IEEE command, 71
 - triggering CHPower, 369
 - TSPur limit testing, 101, 135
 - TXPower trigger source, 565
- U**
- uninstall application, 309
 - users, lock-out, 594
- V**
- view ACP data, 155
 - view code domain data, 156
 - view code domain results, 163
 - view commands, 155
 - view EVM data, 157
 - view PVT data, 159
 - view rho data, 160
- W**
- wait, IEEE command, 72

WAVeform
 acquisition packing, [566](#)
 ADC dithering, [566](#)
 ADC filter, [566](#)
 ADC range, [567](#)
 data decimation, [571](#)
 sweep time, [572](#)
 trigger source, [572](#)
 waveform (time domain)
 measurement, [307](#), [566](#)
 See also WAVeform

W-CDMA
 ACP measurement, [326](#), [331](#), [340](#),
 [341](#)
 trigger source, [357](#), [492](#), [493](#)

W-CDMA (3GPP)
 averaging, [409](#), [410](#)
 offset frequencies, [501](#), [516](#), [517](#),
 [528](#)
 offset frequencies auto mode, [502](#),
 [503](#), [518](#)
 spectrum emission mask
 measurement, [509](#), [510](#), [512](#),
 [513](#), [514](#), [515](#), [523](#), [524](#), [525](#),
 [526](#), [527](#), [528](#)
 trigger source, [413](#), [531](#)

W-CDMA (3GPP) measurement, [198](#),
 [209](#), [246](#), [249](#), [252](#), [254](#), [259](#),
 [265](#), [271](#), [286](#), [408](#), [416](#), [422](#),
 [426](#), [454](#), [496](#)

W-CDMA (Trial & ARIB)
 averaging, [409](#), [410](#)
 trigger source, [413](#)

W-CDMA (Trial & ARIB)
 measurement, [198](#), [209](#), [246](#),
 [259](#), [265](#), [271](#), [408](#), [454](#)

W-CDMA measurement, [317](#)

window focus move control, [170](#)

WMF screen files, [313](#)

X

x-axis couple control, [170](#)
x-axis reference level, [171](#)
x-axis reference position, [171](#)
x-axis scale/div, [170](#)

Y

y-axis couple control, [171](#)
y-axis reference level, [172](#)
y-axis reverence position, [172](#)
y-axis scale/div, [172](#)

Z

zero span measurement, [307](#), [566](#)
zoom the display, [158](#)

